

**CALIFORNIA COASTAL COMMISSION**

South Coast Area Office  
 200 Oceangate, Suite 1000  
 Long Beach, CA 90802-4302  
 (562) 590-5071

**W22a**

Filed:	07/23/2015
180th Day:	01/19/2016
Staff:	E.Prahler-LB
Staff Report:	07/24/2015
Hearing Date:	08/12/2015

**STAFF REPORT: PERMIT AMENDMENT**

<b>Application No.:</b>	<b>5-98-156-A21</b>
<b>Co-Permittees:</b>	<b>City of Long Beach &amp; DDR Urban, LP</b>
<b>Agents:</b>	Dongell Lawrence Finney, LLP (Tal Finney and Courtney Ross-Tait)
<b>Location:</b>	95 S. Pine Avenue (The Pike at Rainbow Harbor), Downtown Shoreline, City of Long Beach, Los Angeles County
<b>Description of Amendment:</b>	Amend comprehensive sign program, including new directional signs and new artwork and copy on existing signs for new tenants.
<b>Description of Project Originally Approved February 3, 1999:</b>	Construction of a 508,550 sq. ft. commercial retail and entertainment complex on the waterfront. See Appendix B for descriptions of previous permit amendments: A1-A20.
<b>Staff Recommendation:</b>	Approve with conditions

**SUMMARY OF STAFF RECOMMENDATION**

This application would amend the Commission-issued coastal development permit for the commercial waterfront development known as “The Pike at Rainbow Harbor” (referred to as “The Pike”). Only one sign would be located within a protected view corridors, however that directory sign will be located at the inland edge of a view corridor, will be attached to an existing valet waiting area approved by the Commission, and will not block any significant public views of the water. Another sign is proposed to exceed a previously imposed height restriction by approximately five feet, however, this sign is not located within a protected view corridor and is consistent with the certified LCP. The proposed sign program does not: a) obstruct views to or along the coast from publicly accessible places; b) adversely impact public access to and use of the water; c) adversely affect recreation, access or the visual resources of the coast. The amendment request is consistent

with the Chapter 3 policies of the Coastal Act, previous Commission approvals and the certified Long Beach LCP.

Staff is recommending **approval** of the proposed coastal development permit amendment with no additional special conditions.

**Procedural Note:**

The Commission's regulations provide for referral of permit amendment requests to the Commission if:

- 1) The Executive Director determines that the proposed amendment is a material change,
- 2) Objection is made to the Executive Director's determination of immateriality, or
- 3) The proposed amendment affects conditions required for the purpose of protecting a coastal resource or coastal access.

If the applicant or objector so requests, the Commission shall make an independent determination as to whether the proposed amendment is material. 14 Cal. Admin. Code 13166.

The proposed project is a material change from that previously approved. In addition, the proposed amendment affects conditions required for the purpose of protecting a coastal resource or coastal access. Therefore, pursuant to Section 13166 of the Commission's regulations, the Executive Director is referring this application to the Commission.

The project site falls entirely within the Commission's original jurisdiction. A portion of the proposed project is located on filled State Tidelands administered by the City of Long Beach. The permit amendment must be obtained from the Commission because the Commission issued the underlying coastal development permit. The Commission's standard of review for the development within the Commission's area of original jurisdiction is the Chapter 3 policies of the Coastal Act. The City of Long Beach certified Local Coastal Program (LCP) is advisory in nature and may provide guidance.

## TABLE OF CONTENTS

<b>I. MOTION AND RESOLUTION .....</b>	<b>4</b>
<b>II. STANDARD CONDITIONS.....</b>	<b>4</b>
<b>III. SPECIAL CONDITIONS.....</b>	<b>5</b>
<b>IV. FINDINGS AND DECLARATIONS: .....</b>	<b>6</b>
A. PROJECT LOCATION & DESCRIPTION .....	6
B. SCENIC RESOURCES .....	8
C. PUBLIC ACCESS AND RECREATION .....	10
D. LOCAL COASTAL PROGRAM (LCP).....	10
E. CALIFORNIA ENVIRONMENTAL QUALITY ACT (CEQA).....	11

### APPENDICES

- Appendix A – Substantive File Documents
- Appendix B – Previous Permit Amendments<sup>1</sup>
- Appendix C – Previously Imposed Special Conditions

### EXHIBITS

- Exhibit 1 – Vicinity Maps
- Exhibit 2 – LCP Subareas 5 and 6
- Exhibit 3 – View Corridors (Attachment A)
- Exhibit 4 – Proposed Sign Site Plan
- Exhibit 5 – Sign A.1
- Exhibit 6 – Sign A.2
- Exhibit 7 – Signs B.1 – B.4
- Exhibit 8 – Sign B.5
- Exhibit 9 – Signs B.6 & B.7
- Exhibit 10 – Signs C & E.1-E.8
- Exhibit 11 – Signs D.1-D.11
- Exhibit 12 – Signs T.1 & T.2
- Exhibit 13 – Signs G.1-G.10
- Exhibit 14 – Cinemark Blade Sign
- Exhibit 15 – Wall-Mounted Tenant Signs

---

<sup>1</sup> Full permit amendment files available at the South Coast Commission office in Long Beach.

## I. MOTION AND RESOLUTION

### Motion:

*I move that the Commission **approve** the proposed amendment to Coastal Development Permit Application No. 5-98-156 subject to the conditions set forth in the staff recommendation.*

Staff recommends a YES vote on the foregoing motion. Passage of this motion will result in conditional approval of the permit amendment and adoption of the following resolution and findings. The motion passes only by affirmative vote of a majority of the Commissioners present.

### Resolution:

*The Commission hereby approves a coastal development permit amendment on the ground that the development as amended and subject to conditions will be in conformity with the policies of Chapter 3 of the Coastal Act and will not prejudice the ability of the local government having jurisdiction over the area to prepare a Local Coastal Program conforming to the provisions of Chapter 3. Approval of the permit amendment complies with the California Environmental Quality Act because either 1) feasible mitigation measures and/or alternatives have been incorporated to substantially lessen any significant adverse effects of the development on the environment, or 2) there are no feasible mitigation measures or alternatives that would substantially lessen any significant adverse impacts of the development on the environment.*

## II. STANDARD CONDITIONS

This permit amendment is granted subject to the following standard conditions:

1. **Notice of Receipt and Acknowledgment.** The permit is not valid and development shall not commence until a copy of the permit, signed by the permittee or authorized agent, acknowledging receipt of the permit and acceptance of the terms and conditions, is returned to the Commission office.
2. **Expiration.** If development has not commenced, the permit will expire two years from the date on which the Commission voted on the application. Development shall be pursued in a diligent manner and completed in a reasonable period of time. Application for extension of the permit must be made prior to the expiration date.
3. **Interpretation.** Any questions of intent of interpretation of any condition will be resolved by the Executive Director or the Commission.
4. **Assignment.** The permit may be assigned to any qualified person, provided assignee files with the Commission an affidavit accepting all terms and conditions of the permit.



5. **Terms and Conditions Run with the Land.** These terms and conditions shall be perpetual, and it is the intention of the Commission and the permittee to bind all future owners and possessors of the subject property to the terms and conditions.

### III. SPECIAL CONDITIONS

The following is adopted as part of the Commission's resolution:

This coastal development permit amendment would change Special Condition 18 and Special Condition 19, as detailed below. Proposed changes are presented with eliminated words ~~struck through~~ and new words underlined. Unless specifically changed by this amendment, all standard and special conditions attached to Coastal Development Permit No. 5-98-156 and/or amendments thereto shall remain in effect (See Appendix C).

A. **Change Special Condition 18.b Height Limits – LCP Subarea 5, Building A:**

All buildings, signs, structures, poles and/or building extensions in LCP Subarea 5 that exceed 40 feet in elevation are prohibited, unless specifically permitted by this condition or another Commission approval. In LCP Subarea 5, no portion of the proposed development shall exceed 40 feet in height, except for the following:

- b) On Building A (40 feet): one 500 square foot parapet extension (47 feet maximum), the letters of "~~LONG BEACH~~THE PIKE OUTLETS" sign (~~550~~ feet maximum), and clock tower (60 feet); The hotel at the northeast corner of Bay Street and Cedar Avenue (74 feet maximum to the rooftop pool deck, 83 feet maximum to the top of the stair towers and 90 feet maximum to the top of the elevator housing);

B. **Change Special Condition 19. View Corridors:**

No structures over 42 inches in height, other than required safety features, structures required to meet ADA access standards where there is no alternative location for such structures outside of the view corridors, mobile vending carts, lighting features, low-scale official directional signs, ~~and~~ the valet kiosk and waiting area outside of Building J identified on Exhibit #4.2 of the staff report for Amendment No. 16 dated 10/23/14), and the directory sign attached to the valet waiting area outside of Building J identified on Exhibit #11 of the staff report for Amendment No. 21 dated 7/24/15) shall be placed in the view corridors identified on Exhibit #9 of this staff report (dated 1/14/99). In addition, no restaurant dining areas shall be placed in the view corridors identified on Exhibit #9 of this staff report (dated 1/14/99). However, seats and picnic tables (less than 42 inches in height) for the public picnic areas with no restaurant table service may be provided within view corridors only as shown on Exhibit #9 of the staff report dated February 24, 2000. An arch which contains the lettering "PIER, PINE AVENUE" shall be permitted at the entrance to the Pine Avenue Pier, provided that the bottom edge of the arch is at least twelve feet above the pier so as to not intrude into the protected pedestrian view corridor along the pier to the water.

Prior to issuance of the coastal development permit, the applicants shall submit revised plans that comply with the view corridor protections of this condition. The revised plans shall be

subject to the review and approval of the Executive Director, and shall include the following revisions: a) removal of all items (other than the PINE AVENUE PIER arch) that exceed 42 inches in height from the Pine Avenue Pier view corridor; b) removal of the restaurant dining patios attached to Buildings J and K that encroach into the Terraces view corridor identified on Exhibit #9 of staff report dated 1/14/99 and located at the terminus of Pine Avenue, and c) provision of a 90-foot wide view corridor over Aquarium Way between Building F and Building G south of Shoreline Drive. The development shall conform to the revised plans approved by the Executive Director.

#### **IV. FINDINGS AND DECLARATIONS:**

##### **A. PROJECT LOCATION & DESCRIPTION**

On February 3, 1999, the Commission approved Coastal Development Permit 5-98-156 for the construction of a 508,550 square foot commercial retail and entertainment complex in the Downtown Shoreline area of Long Beach.<sup>2</sup> The approved “Queensway Bay” commercial project, now known as “The Pike at Rainbow Harbor” (the “Pike”), included a multi-screen movie theater, a large-format (IMAX-style) theater, a new 2,195-stall parking structure, a Ferris wheel and carousel, and numerous restaurants, retail establishments and public amenities (Exhibit #1). The Pike has been open to the public since November 2003. The permit has been amended 20 times since 1999 (See Appendix B).

The Pike at Rainbow Harbor is situated on approximately 20 acres of fill (formerly the ocean) which was entirely designated as State Tidelands until 2011 when the City of Long Beach and the State Lands Commission completed a land swap to remove the State Tidelands designation and associated land use restrictions from approximately 10 acres of land in LCP Subarea 5 of the Downtown Shoreline Planned Development District (PD-6). This permit amendment request involves two LCP Subareas: LCP Subarea 5 and LCP Subarea 6 (Exhibit #2). Subarea 6 covers the City’s central waterfront area including Shoreline Park, the Long Beach Aquarium of the Pacific, Rainbow Harbor and Esplanade, and Pine Avenue Pier. Most of the land area within LCP Subarea 6 is located seaward of the first public road. Subarea 5 is a landlocked former “Tidelands Parcel” located inland of LCP Subarea 6 and Shoreline Drive. Subarea 5 includes a cinema, more restaurants, entertainment, the Hyatt The Pike Long Beach, and a 2,211-stall parking garage (the Pike Parking Structure).

On October 7, 2003, the Commission approved Amendment No. 8 (5-98-156-A8) for a comprehensive sign program, as required by Special Condition 20 of Coastal Development Permit 5-98-156. Amendment No. 8 included one fifty-foot high “The Pike” identification sign, fifteen freestanding directory signs, three freestanding “The Pike” identification signs, and one building mounted “The Pike” identification sign. On November 14, 2014, the Commission approved Amendment No. 18 (5-98-156-A18) for the conversion of The Pike at Rainbow Harbor into a retail store outlet center.

---

<sup>2</sup> See Appendix B of this staff report for a list of the previously approved permit amendments.

This permit amendment would allow the co-permittees to update the previously approved comprehensive sign program by replacing existing signs and adding new signs. The proposed signs are necessary to rebrand The Pike as “The Pike Outlets” and to provide directional information to the public.

Special Condition 20 of Coastal Development 5-98-156 states:

**Signage.** All roof signs, freestanding signs, three-dimensional icons, and signs above 40 feet in elevation are prohibited, unless specifically permitted by this permit or another Commission approval. Exceptions: i) Signs attached to the wall of an approved structure that exceeds 40 feet in elevation, and ii) up to seven three-dimensional food icons within the confines of the faux roller coaster, provided that such icons do not exceed 70 feet in height above the flood plain elevation, do not advertise a particular store, product or service, and do not extend south of the north curb of Shoreline Drive. The applicants shall submit a comprehensive sign program, subject to the review and approval of the Commission, for all proposed signs that are not attached to the wall of an approved structure, or specifically approved by this action.

In addition to the types of signage authorized by Special Condition 20, Special Conditions 17, 18 and 19 list several other signs that were specifically authorized by the Commission’s original approval of Coastal Development Permit 5-98-156 (See Appendix C). These previously approved signs include:

- A fifty-foot high “Rainbow Harbor” sign that has since been deleted from the project (Special Condition 17.c).
- Three vertical blade architectural elements on Buildings G & J, provided they do not exceed 60 feet in height, 8 feet in width and 5 feet in thickness, provided that no signage occurs above 40 feet in height, and provided that they do not project into any protected view corridor shown on LCP Attachment A [Exhibit #9 of staff report dated 1/14/99] (Special Condition 17.e).
- On Building A, a fifty-foot high “LONG BEACH” sign (Special Condition 18.b). Amendment No. 8 included the placement of one fifty-foot high “THE PIKE” identification sign on Building A instead of the previously approved fifty-foot high “LONG BEACH” sign. The current amendment request includes the placement of one fifty-four foot, five inch high “THE PIKE OUTLETS” identification sign on Building A instead of the previously approved “THE PIKE” identification sign (Exhibit #6).
- On Building D, a 100-foot high blade sign for theater identification (Special Condition 18.e). The current amendment request includes the addition of one 4 foot x 5 foot panel to the blade sign. This added panel will not exceed the 100-foot height restriction (Exhibit #14).
- The 70-foot high three-dimensional food icons, which have since been deleted from the project (Special Conditions 18.j and 20).
- The “PINE AVENUE PIER” sign (Special Condition 19).

The Commission also authorized several other signs as part of the co-permittees’ comprehensive signage program approved under Amendment No. 8. These previously approved signs include:

- Three 25-foot high freestanding “The Pike” identification signs. The current amendment request includes replacement of these signs and poles with three 24-foot high freestanding “The Pike Outlets” identification signs (Exhibit #7).
- One building mounted “The Pike” identification sign.
- Fifteen ten-foot high freestanding directory signs. The current amendment request includes replacement of nine existing directory signs with eight approximately 8-foot high freestanding directory signs and one wall-mounted directory sign (Exhibit #11).

The currently proposed update to the comprehensive sign program includes the following additional signage:

- One 21-foot high “The Pike Outlets” identification sign attached to an approximately 10-foot high electrical structure (Exhibit #5).
- One additional 24-foot high freestanding “The Pike Outlets” identification sign (Exhibit #7).
- One 16-foot high freestanding “The Pike Outlets” and “Parking Garage” directional sign (Exhibit #8).
- Two 14-foot high freestanding wayfinding signs (Exhibit #9).
- One 6 ft. 5 in. monument “The Pike Outlets Parking” sign (Exhibit #10).
- Two approximately 8-foot high directory signs mounted to the wall of an existing building and to a valet waiting area improvement (Exhibit #11).
- One approximately 14-foot high vehicular directional sign located in the Shoreline Blvd. median (Exhibit #10).
- Seven approximately 14-foot high vehicular directional signs attached to existing light poles (Exhibit #10).
- Two 34-foot high “The Pike Outlets” tower sign (Exhibit #12).
- Ten tenant blade signs that do not exceed the building height (Exhibit #13).

The comprehensive sign program also includes multiple wall-mounted tenant signs that do not require an amendment to Coastal Development Permit No. 5-98-156 (Exhibit #15). The locations of the proposed signs are identified in Exhibit #4. One new directory sign would be located within a view corridor that the underlying permit and the certified LCP protect (Exhibit #3), however, the sign would be mounted to an existing valet waiting area improvement at the inland edge of the view corridor and will not block any significant public views of the water. No other signs would be located within a protected view corridor. With the exception of sign A.2 (the proposed fifty-five foot high “THE PIKE OUTLETS” sign shown in Exhibit #6), the proposed sign program conforms to all of the limitations and conditions previously imposed on the proposed development (See Appendix C).

## **B. SCENIC RESOURCES**

Coastal Act section 30251 states in relevant:

*The scenic and visual qualities of coastal areas shall be considered and protected as a resource of public importance. Permitted development shall be sited and designed to protect views and along the ocean and scenic coastal areas...to be visually compatible with the character of surrounding areas...*

In its prior actions on LCP amendments, Coastal Development Permit 5-98-156 and permit amendments for the Pike project, the Commission has considered and addressed the project's effects on scenic resources in Downtown Long Beach. In 1995, when the Commission first incorporated the City's Queensway Bay Development Plan (which includes the Pike development) into the certified LCP by approving LCP Amendment No. 1-95, it required that specific policies be included in the plan to protect the scenic resources of the Downtown Shoreline area (e.g., view corridors, building mass limits and height limits). In 1998, the Commission re-visited the certified LCP policies that limit building heights and protect specific view corridors on the project site as part of the Commission's certification of LCP Amendment No. 2-98A, which included revisions to the City's previously certified Queensway Bay Development Plan.

The currently certified Long Beach LCP contains a map (LCP Attachment A) that identifies the special view corridors in LCP Subareas 5 and 6 that must be protected in order to provide views from the land to the water (Exhibit #3). The protected view corridors in LCP Subareas 5 and 6 include: a 410-foot long view corridor/open space area on Shoreline Wharf, a 160-foot wide view corridor at the intersection of Shoreline Drive and Pine Avenue extending to Pine Circle and the air space above the Terraces at the terminus of Pine Avenue, the Pine Avenue Pier corridor, the sixty-foot wide Pine Avenue view corridor and its extension to the water, a 60-foot wide view corridor extending southeast from the intersection of Pine Avenue and Shoreline Drive, and a 90-foot wide view corridor at the intersection of Aquarium Way and Shoreline Drive.

Although the site plan submitted by the applicant shows that several signs are located at or near the edge of view corridors (see, e.g., signs E.4, D.8, D.2, E.7, and E.8 show on Exhibit #4), a site visit by Commission staff confirmed that these signs are in fact outside of the protected view corridors identified on the Long Beach LCP view corridor map (Exhibit #3). The only sign proposed to be located within an existing view corridor is a directory sign (D.11) mounted to a previously approved valet waiting area structure on South Pine Avenue in front of Building J (Exhibit #4, page 2 and Exhibit #11). The valet waiting area that this sign will be attached to is located at the inland edge of the one hundred sixty-foot wide Shoreline Drive/Pine Avenue view corridor and will not block any significant public views of the water. Special Condition 19 is revised by this permit amendment in order to reflect the Commission's approval of the proposed directory sign mounted to the valet waiting area structure.

The certified LCP also protects public views to and along the shoreline by restricting the height of development within LCP Subareas 5 and 6 to a maximum of forty feet. However, the certified LCP allows architectural features "to extend above these height limits if they do not contain any usable interior space and do not significantly affect public views." Special Condition 18.b imposed a fifty-foot height limit for a "LONG BEACH" sign on Building A. Amendment No. 8 included the placement of one fifty-foot high "THE PIKE" identification sign on Building A instead of the previously approved fifty-foot high "LONG BEACH" sign. In this amendment request, the applicant proposes to replace the existing "THE PIKE" identification sign with a "THE PIKE OUTLETS" identification sign (Exhibit #6). The applicant will attach the letters of the new sign to the existing background. The top of the proposed sign exceeds the fifty-foot height restriction by approximately five feet. This sign is not located within any protected view corridors and increasing the height by up to five feet is consistent with the certified LCP because this architectural feature does not contain any usable interior space and does not significantly impact public views. Special

Condition 18.b is revised by this permit amendment in order to reflect the Commission’s approval of the increased height of the proposed “THE PIKE OUTLETS” sign attached to Building A.

With the exception of one directory sign mounted to an existing valet waiting area, no signage is proposed to be located within any of the view corridors that the underlying permit and the certified LCP protect through the project site (Exhibit #3). As described above, that directory sign that is proposed at the inland edge of a protected view corridor will not block any significant public views of the water. In addition, all but one proposed sign complies with existing height restrictions. The proposed “THE PIKE OUTLETS” identification sign on Building A will be approximately five feet higher than originally approved, but is consistent with the certified LCP. The proposed sign program does not: a) obstruct views to or along the coast from publicly accessible places; b) adversely impact public access to and use of the water; c) adversely impact public recreational use of a public park or beach; or d) otherwise adversely affect recreation, access or the visual resources of the coast. Therefore, the proposed comprehensive sign program and the amendment request are consistent with the Chapter 3 policies of the Coastal Act, previous Commission approvals and the certified Long Beach LCP.

### **C. PUBLIC ACCESS AND RECREATION**

Coastal Act section 30210 states:

*In carrying out the requirement of Section 4 of Article X of the California Constitution, maximum access, which shall be conspicuously posted, and recreational opportunities shall be provided for all the people consistent with public safety needs and the need to protect public rights, rights of private property owners, and natural resource areas from overuse.*

Coastal Act section 30213 states in part:

*Lower cost visitor and recreational facilities shall be protected, encouraged, and, where feasible, provided. Developments providing public recreational opportunities are preferred.*

Coastal Act section 30252 states in part:

*The location and amount of new development should maintain and enhance public access to the coast by... (4) providing adequate parking facilities or providing substitute means of serving the development with public transportation.*

The proposed development and permit amendment will not have any new adverse impact on public access to the coast or to nearby recreational facilities. As proposed, the development and permit amendment protect coastal areas suited for recreational activities. Therefore, the Commission finds that the proposed development is consistent with the public access and recreation policies of the Coastal Act.

### **D. LOCAL COASTAL PROGRAM (LCP)**

The City of Long Beach Local Coastal Program was certified by the Commission on July 22, 1980, and numerous LCP amendments have been processed since that date. Because the project is located seaward of the former mean high tide line, the LCP is advisory in nature and may provide guidance. The Commission’s standard of review for this amendment is the Chapter 3 policies of the Coastal

Act. The proposed amendment, as conditioned, is consistent with the Chapter 3 policies of the Coastal Act and the certified LCP.

**E. CALIFORNIA ENVIRONMENTAL QUALITY ACT (CEQA)**

Section 13096 Title 14 of the California Code of Regulations requires Commission approval of a coastal development permit application to be supported by a finding showing the application, as conditioned by any conditions of approval, to be consistent with any applicable requirements of the California Environmental Quality Act (CEQA). Section 21080.5(d)(2)(A) of CEQA prohibits a proposed development from being approved if there are feasible alternatives or feasible mitigation measures available which would substantially lessen any significant adverse effect which the activity may have on the environment.

The proposed amendment, as conditioned, is consistent with the Chapter 3 policies of the Coastal Act. All significant environmental effects have been mitigated by conditions of approval. As conditioned, the proposed permit amendment will not have significant environmental effects for which feasible mitigation measures have not been employed consistent with CEQA. Therefore, the Commission finds that the project is consistent with the requirements of the Coastal Act to conform to CEQA.

## **Appendix A – Substantive File Documents**

1. City of Long Beach Certified Local Coastal Program (LCP), 7/22/80.
2. Coastal Development Permit No. 5-98-156 & Amendment Nos. 1-20 (Pike/Queensway Bay).

## **Appendix B – Previous Permit Amendments**

FIRST AMENDMENT (5-98-156-A1), APPROVED NOV. 2, 1999:

Modify previously approved 70-foot high parking structure to expand the building footprint over Chestnut Place and increase number of parking stalls from 1,550 to 2,195 (approx).

SECOND AMENDMENT (5-98-156-A2), APPROVED DEC. 9, 1999:

Part A: Construct a 375-stall surface parking lot for employees in LCP Subarea 3.

Part B: Increase the previously approved parking structure rates from \$2/hour to \$3/hour, and modify the customer parking validation program.

THIRD AMENDMENT (5-98-156-A3), APPROVED FEBRUARY 15, 2000:

Part A: Subdivide approximately 20 acres of State Tidelands into eight parcels.

Part B: Change the “Paseo” from a pedestrian-only street to a vehicular street with sidewalks.

FOURTH AMENDMENT (5-98-156-A4), APPROVED MARCH 14, 2000:

Part A: Revised plans for Building F resulting in less commercial floor area, a smaller public viewing deck, and a wider Aquarium Way view corridor (90 feet).

Part B: Construct a public pedestrian accessway along the south side of Shoreline Drive to connect LCP Subarea 3 to LCP Subareas 5 and 6.

Part C: Identify appropriate locations for public picnic areas (no table service) on the upper Esplanade of Rainbow Harbor.

FIFTH AMENDMENT (5-98-156-A5), APPROVED JANUARY 11, 2001:

Revise the conditions of approval in order to allow the phased construction and opening of the development approved in LCP Subarea 6 (between Rainbow Harbor and Shoreline Drive) prior to the construction of the portion of the project located inland of Shoreline Drive (LCP Subarea 5) and in LCP Subarea 3.



SIXTH AMENDMENT (5-98-156-A6), APPROVED JANUARY 10, 2003:

Revise the building footprints, floor plans and elevations for the restaurant and retail development previously approved south of Shoreline Drive in LCP Subarea 6, between Aquarium Way and the Pine Avenue View Corridor (Rainbow Harbor).

SEVENTH AMENDMENT (5-98-156-A7), APPROVED JULY 16, 2003:

Revise building footprints, floor plans and elevations for the commercial development previously approved north of Shoreline Drive in LCP Subarea 5, and delete the escalator and pedestrian connection between the Aquarium parking structure and Building F, located south of Shoreline Drive in LCP Subarea 6.

EIGHTH AMENDMENT (5-98-156-A8), APPROVED OCTOBER 7, 2003:

Comprehensive sign program, including fifteen freestanding directory signs, three freestanding "The Pike" identification signs, one building mounted "The Pike" identification sign, and a flagpole at the base of Pine Avenue Pier on Building K parcel.

NINTH AMENDMENT (5-98-156-A9), APPROVED DEC. 11, 2003:

Relocate the previously approved Ferris wheel amusement ride to an open space area near the northwest corner of Shoreline Drive and Pine Avenue.

TENTH AMENDMENT (5-98-156-A10), APPROVED JANUARY 15, 2004:

Delete the previously approved nautical museum (Building M) at the foot of Pine Avenue Pier, and incorporate the site into the adjacent restaurant use (Building N).

ELEVENTH AMENDMENT (5-98-156-A11), APPROVED MARCH 16, 2005:

Install 24 Retail Merchandising Units (RMUs) in 24 specific sidewalk and plaza locations north of Shoreline Drive (LCP Subarea 5), within the previously approved Pike at Rainbow Harbor retail and entertainment complex.

TWELFTH AMENDMENT (5-98-156-A12), NOT APPROVED (RETURNED INCOMPLETE):

Amend the Employee Parking Program required by Special Condition Sixteen.

THIRTEENTH AMENDMENT (5-98-156-A13), APPROVED MAY 11, 2005:

South of Shoreline Drive, re-subdivide four acres designated for commercial land use (Parcel Nos. 1-4 of Map No. 25804) into Parcel Nos. 1-9 of Map No. 61999. The proposed subdivision slightly reconfigures, and further divides, four existing lots into nine lots totaling four acres.

5-98-156-A21 (City of Long Beach & DDR Urban, LP)

FOURTEENTH AMENDMENT (5-98-156-A14), APPROVED NOV. 18, 2005:

Install three automatic teller machines (ATMs) within the previously approved Pike at Rainbow Harbor retail and entertainment complex.

FIFTEENTH AMENDMENT (5-98-156-A15), APPROVED MAY 10, 2006:

Construct a ninety-foot high, 140-room hotel on a vacant parcel where the underlying permit approved an eighty-foot high large-format movie theater.

SIXTEENTH AMENDMENT (5-98-156-A16), APPROVED NOVEMBER 14, 2014:

Continuation and expansion of valet parking operations, installation of valet parking amenities and other parking-related physical improvements, and update to parking fees and validation program.

SEVENTEENTH AMENDMENT (5-98-156-A17), APPROVED DEC. 9, 2009:

Construct a five-story, 125-room hotel with 14,725 square feet of ground-floor retail space.

EIGHTEENTH AMENDMENT (5-98-156-A18), APPROVED NOVEMBER 14, 2014:

Redevelopment of The Pike at Rainbow Harbor commercial retail and entertainment complex into a retail store outlet center, including exterior façade changes, addition of 1,785 sq. ft. to Building B2 and 2,500 sq. ft. to Building D, enlargement of the central plaza, placement of bollards for temporary closure of portions of Bay Street, The Paseo, and Aquarium Way to vehicular traffic, new bike repair station, and landscaping improvements. Includes the expansion of Building G1 outdoor dining patio expansion, and construction of a pedestrian bridge over Cedar Avenue to connect Pike Parking Structure level three and Building E level two.

NINETEENTH AMENDMENT (5-98-156-A19), APPROVED OCTOBER 15, 2014:

Construction of approximately 40,310 square feet of new commercial space, connected to existing 9,950 square foot commercial space at Building E location, resulting in an approximately 50,260 square foot, 45-foot 8-inch high, two-story commercial building.

TWENTIETH AMENDMENT (5-98-156-A20), APPROVED JULY 9, 2015:

Create 33 additional on-street metered parking stalls along Shoreline Drive in lieu of adding 32 parking stalls in the Queensway Bay (Aquarium) parking structure.

## Appendix C – Previously Imposed Special Conditions

Appendix C includes all special conditions that apply to this development as approved by the Commission in its original action 5-98-156 and all subsequent amendments to the permit through Amendment No. 20. Typographical errors have been corrected for consistency and references to specific amendments are noted in *[brackets]*.

### SPECIAL CONDITIONS:

1. **Replacement Parkland.** *[Condition Satisfied 11/5/99]*

Prior to issuance of the coastal development permit, the City shall submit for the review and approval of the Executive Director, a resolution adopted by the City Council designating the Queen Mary Events Park as a permanent public park of not less than four-acres in area, and served by a minimum of ten parking spaces on the adjacent public roadway (See Exhibit #6 of staff report dated 1/14/99). The resolution shall also state that any change in the designation of the four-acre Queen Mary Events Park as a permanent public park shall not be effective unless approved by the California Coastal Commission. The City shall be responsible for ensuring that the Queen Mary Events Park is maintained and operated as a public park available for use by the general public everyday from 5 a.m. to 10 p.m. (except during special events).

2. **Final Plans: LCP Subarea 6.** *[As Revised by Commission Approval of 5-98-156-A10]*

Prior to the commencement of construction of proposed Buildings G1, G2, H1 and H2, the applicants shall submit for the review and approval of the Executive Director, final site plans, floor plans and elevations. Buildings J, K and P are approved as shown on Exhibits #5-8 of the staff report dated 12/19/02. Building N is approved as shown on Exhibits #5&6 of the staff report dated 12/17/03. The plans for Buildings G1, G2, H1 and H2, and all commercial development in LCP Subarea 6 (Buildings F, G1, G2, H1, H2, J, K, N and P), shall comply with all of the following conditions:

- a. No portion of the structures or patio areas shall encroach into the view corridors identified on Exhibit #5 (of staff report dated 12/19/02).
- b. No portion of the structures shall exceed 40 feet in height measured from the nearest curb, except as authorized by Special Condition 17 of Coastal Development Permit 5-98-156 as amended.
- c. All proposed commercial development (including all building area, indoor and outdoor service areas, patios and loading areas) shall be located entirely within the boundaries of Parcels 1-4 (Parcel Map No. 25804) as approved by the Commission pursuant to Permit Amendment 5-98-156-A3.
- d. The total amount of commercial floor area (including restaurant patios) in the portion of the project located south of Shoreline Drive shall not exceed 202,700 square feet.

- e. The plans shall conform to all terms and conditions of Coastal Development Permit 5-98-156 as amended.

The permittee shall undertake the development in accordance with the final plans approved by the Executive Director pursuant to this condition. Any proposed changes to the approved plans shall be reported to the Executive Director in order to determine if the proposed change shall require a permit amendment pursuant to the requirements of the Coastal Act and the California Code of Regulations. No changes to the approved plans shall occur without a Commission amendment to this coastal development permit unless the Executive Director determines that no amendment is required.

**3. Future Uses and Improvements.**

This approval is limited to the uses and development specifically described in the project description, approved plans and related findings contained in Coastal Development Permit 5-98-156. Any additional development, including, but not limited to: new construction; intensification of use; expansion of dining areas outside of the approved building and patio footprints; and the lease of dock, esplanade or park areas, will require an amendment to the permit or a new coastal development permit.

**4. Public Viewing Deck.**

The proposed 17,749 square foot public viewing deck on the second level of the building (Building F) proposed to be built between the City-owned parking structure and Aquarium Way shall be constructed and opened to the public concurrent with the development that occurs within the 150-foot wide view corridor/open space area at the intersection of Shoreline Drive and Aquarium Way (See Exhibit #9 of staff report dated 1/14/99). The public viewing deck shall be available for public use, including picnics, as public parks are. Park benches and tables for picnics shall be provided for general public use on the viewing deck. Take-out and walk-up food services are encouraged behind the viewing deck, but restaurant table service is prohibited. Commercial uses and kiosks are prohibited within the proposed 17,749 square foot public viewing deck. Signs, at least two square feet in area, shall be posted in at least three conspicuous ground level locations near the Building F stairways and elevators that inform and direct the public to the public viewing deck.

**5. Public Open Space and Water Feature.**

The proposed landscaped public open space area with a water feature located at the northwest corner of Pine Avenue and Shoreline Drive shall be constructed and opened to the public concurrent with the permitted development that occurs in LCP Subarea 5 (See Exhibit #13 of staff report dated 1/14/99). The landscaped and water area shall occupy at least 23,000 square feet, not counting the paved area of the Regional Bicycle Route, and shall be available for public use as public parks are. Pedestrian access to the public open space area shall be provided from the sidewalks on Shoreline Drive and Pine Avenue. Public park benches shall be provided, and restaurant table service shall not be permitted in this area.

**6. Public Access.**

The City and its agents shall provide and maintain unobstructed public access to and along the waterfront at all times. Unrestricted means that the general public may pass and repass without having to pay an admission fee, present a ticket, accept conditions of passage, or request permission to pass. The waterfront, where unrestricted public access shall be protected, includes (but is not limited to): Shoreline Park, Rainbow Harbor Esplanade, the Terraces at the end of Pine Avenue, the entrance to Pine Avenue Pier, and Shoreline Wharf. Unrestricted pedestrian public access shall also be provided on the Promenade South which connects Ocean Boulevard to the Shoreline Wharf area. Public access along the waterfront shall remain open and unobstructed both during construction and subsequent to completion of the permitted development. In extreme circumstances, public access may be interrupted subject to those temporary safety limitations necessitated by unsafe conditions resulting from waves, extreme weather or required construction and maintenance activities.

Public seating and tables for designated public picnic areas (restaurant table service is prohibited) may be provided on the upper portion of the Rainbow Harbor Esplanade as shown on Exhibit #9 of the staff report dated February 24, 2000. All tables placed in the areas designated on Exhibit #9 of the staff report dated February 24, 2000 shall be clearly designated for use by the general public and shall be engraved or posted with signs stating: "No Purchase Required". Areas where restaurant table service is prohibited includes (but is not limited to): Shoreline Park, Rainbow Harbor Esplanade (upper and lower portions), the Terraces at the end of Pine Avenue, the entrance to Pine Avenue Pier, and Shoreline Wharf.

**7. Pedestrian Bridge over Shoreline Drive.**

The proposed pedestrian bridge over Shoreline Drive connecting Subareas 5 and 6 shall be constructed and opened to the general public concurrent with the development that occurs within LCP Subarea 5. The bridge shall be at least 25 feet wide and be at the same elevation as the proposed 17,749 square foot public viewing deck to be provided between Aquarium Way and the City-owned parking structure in LCP Subarea 6 (See Exhibit #10 of staff report dated 1/14/99). The bridge shall be designed to provide open views to Rainbow Harbor and the Queen Mary which open up as one crosses the bridge from the north to the south. All railings, signs and decorations on the bridge shall be limited to a maximum height of four feet measured from the pedestrian deck, except that a 100-foot high gateway sculptural element may be placed on the bridge, providing that its surface is not more than 15 percent solid or opaque. Seven large food icons not to exceed 70 feet are permitted within the gateway sculptural element provided that they do not extend south of the north curb of Shoreline Drive. Commercial uses, including restaurant table service, are not permitted on the bridge. All heights shall be measured from the average elevation at the front top of the curblines, or from the officially mapped flood hazard level of 13.8 feet above mean lower low water (MLLW), whichever is higher.

**8. Streets and Sidewalks.**

The City and its agents shall provide and maintain unobstructed public pedestrian access to and along all streets, sidewalks, plazas and public open space areas constructed pursuant to

the Commission's approval of Coastal Development Permit 5-98-156 for the life of the development approved herein. Unrestricted means that the general public may pass and re-pass without having to pay an admission fee, present a ticket, accept conditions of passage, or request permission to pass. Public access may only be interrupted for special events with a duration of 48 hours or less, or by special events permitted by a subsequent coastal development permit. Public access may also be interrupted subject to those temporary safety limitations necessitated by unsafe conditions resulting from waves, extreme weather or required maintenance activities.

9. **Regional Bicycle Route.**

The proposed project shall not interfere with the public's use of the regional bicycle path as it passes through the Downtown Shoreline area. In order to maintain the existing bicycle and pedestrian connection between the Los Angeles River bicycle path and the beach bicycle path east of the Downtown Marina, the City and its agents shall maintain unobstructed public pedestrian and bicycle access to and along the regional bicycle route where it passes through the project site. The regional bicycle path shall remain open and unobstructed both during construction and subsequent to completion of the permitted development. If construction of the permitted development necessitates a temporary detour of the bicycle route, the applicants shall submit a temporary detour plan, for the review and approval of the Executive Director. The temporary detour plan shall maintain a safe bicycle and pedestrian connection between the Los Angeles River bicycle path and the beach bicycle path east of the Downtown Marina. The City shall provide adequate signage to identify any temporary detour route approved by the Executive Director. A temporary detour route approved by the Executive Director shall be constructed and opened for public use prior to the closing of any portion of the existing regional bicycle route.

10. **New Parking.** *[As Revised by Commission Approval of 5-98-156-A18]*

In order to permit the phased construction and opening of the development approved in LCP Subarea 6 (between Rainbow Harbor and Shoreline Drive) prior to the construction of the parking facilities located in LCP Subarea 5 (inland of Shoreline Drive), the applicants shall construct and open for public use the following parking facilities in LCP Subarea 6 as follows:

- a) Up to 114,200 square feet of commercial development may be constructed and opened in LCP Subarea 6 utilizing the 571 unallocated parking spaces within the existing 1,471 space City-owned parking structure as the primary parking supply;
- b) Prior to the City's issuance of the first certificate of occupancy for development in LCP Subarea 6 exceeding the 114,200 square foot threshold, the applicants shall open for public use the on-street parking spaces on Shoreline Drive in LCP Subareas 6 and 11 (approximately 189-245 spaces) and the 100-150 space public parking lot located in Shoreline Park at the southwest intersection of Pine Avenue and Shoreline Drive.

Prior to the City's issuance of the first certificate of occupancy for development in LCP Subarea 5 authorized by amended Coastal Development Permit 5-98-156, the applicants shall

open for public use the 2,195 space parking structure in LCP Subarea 5 and the approximately 333 on-street parking spaces on Pine Avenue, Seaside Way, and on the new street grid to be developed within LCP Subarea 5.

In addition, within ninety days of the establishment of any new parking spaces or removal of any of the proposed parking spaces listed in this condition, the City shall submit final plans, for the review and approval of the Executive Director, which show the exact number and location of all parking spaces (on-street, surface lot, and structure) provided pursuant to this condition. The final plans shall be in substantial conformance with the conceptual plans submitted with Amendment Nos. 16 and 18, and as specifically described in the staff reports dated 10/23/14. Any deviation from the conceptual plans shall be submitted to the Executive Director to determine whether an amendment to this permit is necessary pursuant to the requirements of the Coastal Act and the California Code of Regulations.

**11. Traffic and Parking Management Association.**

The applicants and all designated operators and managers of the parking facilities approved herein shall participate in the Traffic and Parking Management Association established pursuant to the City of Long Beach certified Local Coastal Program [see certified LCP Downtown Shoreline Planned Development Plan (PD-6): General Development and Use Standard (b)6]. The City shall include the parking resources approved by this permit in the total parking resources addressed by the Traffic and Parking Management Association.

**12. Lease to Private Operators.**

The lease of any development or land area subject to Coastal Development Permit 5-98-156 shall explicitly incorporate provisions for public use, public access, employee parking, parking fees and management practices consistent with all conditions contained herein. All findings and conditions of approval adopted by the Commission pursuant to its approval of Coastal Development Permit 5-98-156 shall be attached as an exhibit to all leases of property, development, or land area within the project.

**13. Public Parking.** *[As Revised by Commission Approval of 5-98-156-A16]*

All parking within LCP Subareas 5 and 6 shall be reserved for the use of the general public and shall be available for use on a first-come, first-served basis. There shall be no exclusive use of parking spaces or reserved parking spaces within the approved structure by any person or group other than the general public (handicapped spaces excluded). A portion of the public parking spaces in the parking structures and the surface parking lot located at the southwest corner of Shoreline Drive and Pine Avenue (as described in Condition 14) may be set aside in order to provide the general public and hotel guests with valet or assisted parking on a first-come, first-served basis.

Parking fees, as authorized by a Commission action, may be charged for parking, except that parking shall be free between the hours of 1 a.m. and 10 a.m. in the surface parking lot located within Shoreline Park at the southwest corner of Shoreline Drive and South Pine Avenue.

**14. Valet Parking.** *[As Revised by Commission Approval of 5-98-156-A16]*

In order to increase the capacity of parking facilities and provide service to the public, valet or assisted parking services may be provided within LCP Subareas 5 and 6 provided that such valet or assisted parking is available to the general public on a first-come, first-served basis. The use of on-street parking spaces for valet parking is prohibited.

Valet or assisted parking services may be provided within the public parking lot located in Shoreline Park at the southwest corner of Shoreline Drive and South Pine Avenue (surface lot) only as follows:

- (i) Monday through Friday only after 5 p.m.;
- (ii) Saturdays and Sundays after 10 a.m.; and
- (iii) Special events and holidays all-day.

In addition, and consistent with the Final Parking Management Plan submitted pursuant to Special Condition 44, the reservation and use of specific parking stalls in the surface lot shall be managed as follows:

- (i) thirteen (13) stalls in the northwest corner of the surface lot may be set aside for valet parking at all times;
- (ii) between the hours of 2 p.m. and 5 p.m. Monday through Friday, the valet will have the option to use up to an additional twenty-two (22) stalls within the surface lot; and
- (iii) twelve (12) waterfront, short-term parking stalls shall be available for self-parking at all times and the use of these stalls for valet parking is prohibited.

Any change in the approved valet parking program described in the application and approval of Amendment No. 16 may require a coastal development permit amendment. The co-permittees shall submit any proposed change in the valet or assisted parking program to the Executive Director to determine whether an amendment to this permit is necessary pursuant to the requirements of the Coastal Act and the California Code of Regulations. No changes to the approved valet parking program shall occur without a Commission-approved permit amendment unless the Executive Director determines that no permit amendment is required.

**15. Parking Fees and Validations.**

Any change in the approved parking rates or parking validation system described in the application and approval of Coastal Development Permit 5-98-156 may require a coastal development permit amendment. The applicants shall submit any proposed change in the parking fees or change in the parking validation system to the Executive Director to determine whether an amendment to this permit is necessary pursuant to the requirements of the Coastal Act and the California Code of Regulations.

**16. Employee Parking Program.** *[Program Approved by Commission 3/14/00]*

Prior to issuance of the coastal development permit, the applicants shall submit an employee parking program, subject to the review and approval of the Commission in a permit compliance or permit amendment hearing, which meets the following criteria:



- a) The plan identifies employee parking reservoir(s) of at least 375 spaces that will be available to all employees of the commercial development permitted by Coastal Development Permit 5-98-156 while they are working; and,
- b) None of the 375 employee parking spaces shall be located in the public parking areas located in LCP Subareas 5 and 6; except that LCP Subarea 5 may be used on an interim basis to provide employee parking for development approved in LCP Subarea 6 pursuant to amended Coastal Development Permit 5-98-156 until such time as it is displaced. The Employee Parking Program approved by the Commission on March 14, 2000 (or as amended by a subsequent Commission action) shall be implemented prior to the displacement of any required employee parking spaces in LCP Subarea 5; and,
- c) None of the 375 parking spaces are more than 2,000 feet from the project site unless: (i) they are located within 200 feet of an existing free public transit (Passport) stop, and (ii) the schedules and frequency of the shuttles and choice of routes will not significantly increase commute times such that employees will have an incentive to park in public lots to avoid being late for work; and,
- d) The plan insures that the employee parking is provided to employees at a cost that does not exceed the cost of parking in nearby public parking lots (such as the metered on-street spaces and parking within the Marina Green and Shoreline Park parking areas), and,
- e) The plan identifies the signs, notices and other measures that will inform all employees of the commercial developments approved herein of the employee parking program.

The applicants shall implement the employee parking program as approved by the Commission.

17. **Height Limits - LCP Subarea 6.** *[As Revised by Commission Approval of 5-98-156-A18]*

All buildings, signs, structures, poles and/or building extensions in LCP Subarea 6 that exceed 40 feet in elevation are prohibited unless specifically permitted by this condition or another Commission approval. In LCP Subarea 6, no portion of the proposed development shall exceed 40 feet in height, except for the following:

- a) The south end of the faux roller coaster (100 feet maximum with a surface that is less than 15 percent solid or opaque);
- b) Sails, sail columns and flag poles on Building F (sails and sail columns 60 feet maximum, flag poles 75 feet maximum);
- c) The letters of “RAINBOW HARBOR” sign (50 feet maximum);
- d) Flag poles on Buildings G,H & J (77 feet maximum), and,
- e) Three vertical blade architectural elements on Buildings G & J, provided they do not exceed 60 feet in height, 8 feet in width and 5 feet in thickness, provided that no signage

occurs above 40 feet in height, and provided that they do not project into any protected view corridor shown on LCP Attachment A (Exhibit #9 of staff report dated 1/14/99).

All heights shall be measured from the average elevation at the front top of the curblin, or from the officially mapped flood hazard level of 13.8 feet above mean lower low water (MLLW), whichever is higher.

18. **Height Limits - LCP Subarea 5.** *[As Revised by Commission Approval of 5-98-156-A15, A18, and A19]*

All buildings, signs, structures, poles and/or building extensions in LCP Subarea 5 that exceed 40 feet in elevation are prohibited, unless specifically permitted by this condition or another Commission approval. In LCP Subarea 5, no portion of the proposed development shall exceed 40 feet in height, except for the following:

- a) The north end of the faux roller coaster (100 foot maximum with a surface that is less than 15 percent solid or opaque) and two lantern features abutting the north end of the faux roller coaster (63 & 78 feet maximum);
- b) On Building A (40 feet): one 500 square foot parapet extension (47 feet maximum), the letters of "LONG BEACH" sign (50 feet maximum), and clock tower (60 feet); The hotel at the northeast corner of Bay Street and Cedar Avenue (74 feet maximum to the rooftop pool deck, 83 feet maximum to the top of the stair towers and 90 feet maximum to the top of the elevator housing);
- c) On Building B (40 feet): one 500 square foot building extension (43 feet maximum);
- d) On Building C (40 feet): the roof of the multi-screen theater (60 feet maximum), one barrel element extension (43 feet maximum), one barrel element extension (60 feet maximum), and two 500 square foot towers (60 & 93 feet maximum);
- e) On Building D (40 feet): the roof of the multi-screen theater (60 feet maximum), one barrel element extension (78 feet maximum) with one blade (100 feet maximum) for theater identification sign, and 2,000 square foot tower (52 feet maximum);
- f) Ferris wheel (90 feet maximum);
- g) Parking structure (Amendment 5-98-156-A1 approved a 100-foot architectural tower);
- h) In the town square: one vertical monument with a footprint not to exceed 500 square feet (152 feet maximum);
- i) Flag poles (77 feet maximum);
- j) Up to seven three-dimensional food icons (70 feet maximum) within the confines of the faux roller coaster, provided that such icons do not advertise a particular store, product or

service, and provided that they do not extend south of the north curb of Shoreline Drive;  
and

- k) On Building E at the southeast corner of Bay Street and Cedar Avenue (46 feet maximum).

All heights shall be measured from the average elevation at the front top of the curblines, or from the officially mapped flood hazard level of 13.8 feet above mean lower low water (MLLW), whichever is higher.

19. **View Corridors.** *[As Revised by Commission Approval of 5-98-156-A16]*

No structures over 42 inches in height, other than required safety features, structures required to meet ADA access standards where there is no alternative location for such structures outside of the view corridors, mobile vending carts, lighting features, low-scale official directional signs, and the valet kiosk and waiting area outside of Building J identified on Exhibit #4.2 of the staff report for Amendment No. 16 dated 10/23/14), shall be placed in the view corridors identified on Exhibit #9 of this staff report (dated 1/14/99). In addition, no restaurant dining areas shall be placed in the view corridors identified on Exhibit #9 of this staff report (dated 1/14/99). However, seats and picnic tables (less than 42 inches in height) for the public picnic areas with no restaurant table service may be provided within view corridors only as shown on Exhibit #9 of the staff report dated February 24, 2000. An arch which contains the lettering "PIER, PINE AVENUE" shall be permitted at the entrance to the Pine Avenue Pier, provided that the bottom edge of the arch is at least twelve feet above the pier so as to not intrude into the protected pedestrian view corridor along the pier to the water.

Prior to issuance of the coastal development permit, the applicants shall submit revised plans that comply with the view corridor protections of this condition. The revised plans shall be subject to the review and approval of the Executive Director, and shall include the following revisions: a) removal of all items (other than the PINE AVENUE PIER arch) that exceed 42 inches in height from the Pine Avenue Pier view corridor; b) removal of the restaurant dining patios attached to Buildings J and K that encroach into the Terraces view corridor identified on Exhibit #9 of staff report dated 1/14/99 and located at the terminus of Pine Avenue, and c) provision of a 90-foot wide view corridor over Aquarium Way between Building F and Building G south of Shoreline Drive. The development shall conform to the revised plans approved by the Executive Director.

20. **Signage.**

All roof signs, freestanding signs, three-dimensional icons, and signs above 40 feet in elevation are prohibited, unless specifically permitted by this permit or another Commission approval. Exceptions: i) Signs attached to the wall of an approved structure that exceeds 40 feet in elevation, and ii) up to seven three-dimensional food icons within the confines of the faux roller coaster, provided that such icons do not exceed 70 feet in height above the flood plain elevation, do not advertise a particular store, product or service, and do not extend south of the north curb of Shoreline Drive. The applicants shall submit a comprehensive sign

program, subject to the review and approval of the Commission, for all proposed signs that are not attached to the wall of an approved structure, or specifically approved by this action.

**21. Final Plans: Parking Structure.**

Prior to issuance of the coastal development permit, the applicants shall submit project plans, for the review and approval of the Executive Director, for the parking structure proposed in LCP Subarea 5 on the north side of Shoreline Drive between Cedar Avenue and Chestnut Avenue. The plans for the proposed parking structure shall include features designed to lessen the visual impact of the parking structure, including attractively designed facades, treatments that break up the unrelieved plane of the structure's surface, and special architectural and landscaping features. In addition, the applicants shall submit a drainage plan for the proposed parking structure that incorporates best management practices (BMP's) that will reduce the volume of runoff and amount of pollutants which leave the parking structure site and enter the storm drain system. The drainage plan shall incorporate the following: catch basins to collect trash, trash racks or bars to filter runoff, grease and oil separators, and provisions for periodic cleaning of the paved parking surfaces and catch basins. The drainage plan may include other measures as well. The applicants shall implement the approved drainage plan on an ongoing and permanent basis. The parking structure shall be constructed and maintained in a manner consistent with the plans approved by the Executive Director.

**22. Conformance with the Requirements of the Resource Agencies.**

The applicants shall comply with all permit requirements and mitigation measures of the State Water Resources Control Board, California Department of Fish and Game, U.S. Army Corps of Engineers, and the U.S. Fish and Wildlife Service with respect to preservation and protection of water quality and marine environment. Any change in the approved project which are required by the above-stated agencies shall be submitted to the Executive Director in order to determine if the proposed change shall require a permit amendment pursuant to the requirements of the Coastal Act and the California Code of Regulations.

**23. Drainage Plans for Parking Lot. [Condition Satisfied 9/14/00]**

Prior to issuance of the coastal development permit, the applicants shall submit a drainage plan, for the review and approval of the Executive Director, for the proposed parking lot in Shoreline Park at the southwest corner of Shoreline Drive and Pine Avenue. The drainage plan shall incorporate best management practices (BMP's) that will reduce the volume of runoff and amount of pollutants which leave the parking lot and enter the storm drain system. The drainage plan shall incorporate the following: catch basins to collect trash, trash racks or bars to filter runoff, grease and oil separators, and provisions for periodic cleaning of the paved parking surfaces and catch basins. The drainage plan may include other measures as well. The applicants shall implement the approved drainage plan on an ongoing and permanent basis consistent with the drainage plan approved by the Executive Director.

**24. Assumption of Risk.**

By acceptance of this permit, the applicants acknowledge and agree: (i) that the site may be subject to hazards from seismic events, liquefaction, storms, waves, floods and erosion; (ii) to assume the risks to the applicants and the property that is the subject of this permit of injury and damage from such hazards in connection with this permitted development; (iii) to unconditionally waive any claim of damage or liability against the Commission, its officers, agents, and employees for injury or damage from such hazards; and (iv) to indemnify and hold harmless the Commission, its officers, agents, and employees with respect to the Commission's approval of the project against any and all liability, claims, demands, damages, costs (including costs and fees incurred in defense of such claims), expenses, and amounts paid in settlement arising from any injury or damage due to such hazards.

**25. Consistency with State Tidelands Grant.** *[Condition Satisfied 11/5/99]*

Prior to issuance of the coastal development permit, the applicants shall provide written documentation to the Executive Director, including specific citation of the relevant sections of the applicable State Tidelands Grant, specifically demonstrating that the proposed project in its entirety is consistent with the terms and conditions of the Legislature's grant of this portion of the Downtown Shoreline to the City of Long Beach.

**26. City Acceptance of Conditions.** *[Condition Satisfied 11/5/99]*

Prior to the issuance of the coastal development permit, the City Council shall adopt and submit a resolution, subject to the review and approval of the Executive Director, agreeing to abide by all terms and conditions of Coastal Development Permit 5-98-156. The City and its agents shall abide by all terms and conditions of Coastal Development Permit 5-98-156.

**27. Foundation Design.**

Prior to the commencement of development, the applicants shall submit for review and approval by the Executive Director, final foundation plans for the proposed development (Buildings A,B,C,D,E,F,G,H,J,K,L,M,N,P and the parking structure) that have been reviewed and approved for structural soundness and safety by a qualified engineer. The submitted plans must be in substantial conformance with the plans approved by the Commission. Any changes in the structure design approved by the Commission which may be required by the engineer shall be submitted to the Executive Director to determine whether an amendment to the permit is required. The proposed development shall be constructed in a manner consistent with the final approved plans.

**28. Pedestrian and Bicycle Access (Parking Structure).** *[Condition Satisfied 2/11/00]*

Prior to issuance of the coastal development permit, the applicants shall submit for the review and approval of the Executive Director, revised plans that provide a minimum six-foot wide sidewalk for public pedestrian access through the proposed parking structure on the west side of the Chestnut Place right-of-way. In addition, the applicants shall provide and maintain the bicycle path proposed along the north and east sides of the proposed parking structure that

would connect the existing Chestnut Place bike path to the existing Regional Bicycle Route on the south side of the proposed parking structure (north side of Shoreline Drive). The applicants shall not interfere with public use of the existing Regional Bicycle Route that runs along the north side of Shoreline Drive, the Chestnut Place sidewalk required by this condition, or the proposed bicycle path connecting the Chestnut Place bike path to the Regional Bicycle Route. The development shall be maintained consistent with the plans approved by the Executive Director.

29. **Landscaping and Treatment of Roof (Parking Structure).** *[Condition Satisfied 7/6/00]*

Prior to issuance of the coastal development permit, the applicants shall submit for the review and approval of the Executive Director, a rooftop treatment plan for the proposed parking structure that provides landscaping and surface treatment to soften the visual impact of the parking structure's roof on nearby high-rise buildings. The roof surface shall be treated with material that reflects less light than standard gray concrete. Landscaping shall be provided on the roof to the extent that a minimum of twenty percent (20%) of the total roof area will be covered or shaded within three years of the issuance of the certificate of occupancy for the proposed parking structure. The approved rooftop landscaping shall be installed prior to the issuance of the certificate of occupancy for the proposed parking structure. The development shall be maintained consistent with the plans approved by the Executive Director.

30. **Erosion and Siltation Control (Parking Structure).** *[Condition Satisfied 3/13/2000]*

Prior to the issuance of the coastal development permit, the applicants shall submit, for the review and approval of the Executive Director, an erosion control and siltation prevention plan that incorporates structural and non-structural Best Management Practices (BMPs) to control erosion from the construction site and prevent silt from the construction site from entering the storm drain during construction of the proposed parking structure. The approved erosion control and siltation plan shall conform to the standards of the California Regional Water Quality Control Board and the U.S. Army Corps of Engineers, and shall be implemented during construction.

31. **Drainage Plan (Parking Structure).** *[Condition Satisfied 2/26/2000]*

Prior to issuance of the coastal development permit, the applicants shall submit, for the review and approval of the Executive Director, a drainage plan for the proposed parking structure that incorporates structural and non-structural Best Management Practices (BMPs) to: a) reduce the volume of runoff leaving the parking structure site, b) control the velocity at which the runoff enters the storm water drain, and c) reduce the amount of pollutants contained in the runoff leaving the parking structure site prior to entering the storm drain system. The drainage plan shall incorporate, but not be limited to, the following suggested BMPs: landscaped buffers, catch basins to collect litter, trash racks or bars to filter runoff, grease and oil separators or filters which will aid in the removal of dissolved contaminants, provisions for regular scheduled cleaning of paved parking lot surfaces and catch basins, and maintenance of structural and non-structural BMPs as necessary. The drainage plan may include other measures as well. The permittee shall implement the approved drainage plan on an ongoing

and permanent basis in a manner consistent with the drainage plan approved by the Executive Director. In addition, any lease or operating agreement that involves the proposed parking structure shall explicitly incorporate the provisions of the drainage plan approved by the Executive Director.

**32. Parking Lot Landscaping Plan (Employee Lot/LCP Subarea 3).**

The applicants shall maintain and protect the mature trees as indicated on the proposed project plans, and provide and maintain the landscaping as indicated on the proposed project plans. The proposed project plans are attached as page two of Exhibit #4 of the staff report dated November 18, 1999.

**33. Erosion and Siltation Control (Employee Lot/LCP Subarea 3).** [*Condition Satisfied 3/13/00*]

Prior to the issuance of the coastal development permit amendment (5-98-156-A2), the applicants shall submit, for the review and approval of the Executive Director, an erosion control and siltation prevention plan that incorporates structural and non-structural Best Management Practices (BMPs) to control erosion from the parking lot construction site and prevent silt from the construction site from entering the storm drain during construction of the proposed parking lot. The approved erosion control and siltation plan shall conform to the standards of the California Regional Water Quality Control Board and the U.S. Army Corps of Engineers, and shall be implemented during construction.

**34. Parking Lot Drainage Plan (Employee Lot/LCP Subarea 3).**

Prior to issuance of the coastal development permit amendment (5-98-156-A2), the applicants shall submit, for the review and approval of the Executive Director, a drainage plan for the proposed parking lot that incorporates structural and non-structural Best Management Practices (BMPs) to: a) reduce the volume of runoff leaving the parking lot site, b) control the velocity at which the runoff enters the storm water drain, and c) reduce the amount of pollutants contained in the runoff leaving the parking lot site prior to entering the storm drain system. The drainage plan shall meet the standard of containing on the parking lot site 0.75 inches of precipitation within a 24-hour period. The drainage plan shall incorporate, but not be limited to, the following suggested BMPs: landscaped buffers, catch basins to collect litter, trash racks or bars to filter runoff, grease and oil separators or filters which will aid in the removal of dissolved contaminants, provisions for regular scheduled cleaning of paved parking lot surfaces and catch basins at least once a year between September 15 and October 15, and maintenance of structural and non-structural BMPs as necessary. The drainage plan may include other measures as well. The permittees shall implement the approved drainage plan on an ongoing and permanent basis in a manner consistent with the drainage plan approved by the Executive Director. In addition, any lease or operating agreement that involves the proposed parking lot shall explicitly incorporate the provisions of the drainage plan approved by the Executive Director.

35. **Consistency with State Tidelands Grant (Employee Lot Subarea 3).** [*Condition Satisfied 5/5/00*]

Prior to issuance of the coastal development permit amendment (5-98-156-A2), the applicants shall provide written documentation to the Executive Director, including specific citation of the relevant sections of the applicable State Tidelands Grant, specifically demonstrating that the proposed employee parking lot is consistent with the terms and conditions of the Legislature's grant of this portion of the Downtown Shoreline to the City of Long Beach.

36. **Revised Tentative Parcel Map.** [*Condition Satisfied 8/12/00*]

Prior to issuance of the coastal development permit amendment (5-98-156-A3), the applicants shall submit, for the review and approval of the Executive Director, a revised tentative parcel map that complies with all of the following conditions:

- a) All parcels shall be in the same general location as the parcels shown in Exhibits #5&6 of the staff report dated January 27, 2000;
- b) The total area of the proposed commercial parcels located south of Shoreline Drive (excluding the remainder public park area and one parcel comprised of a public parking lot) shall not exceed a maximum of four acres;
- c) No portion of any proposed commercial parcel located south of Shoreline Drive shall encroach into the view corridors identified on Exhibit #7 of the staff report dated January 27, 2000;
- d) No portion of any proposed commercial parcel shall encroach into the public accessways protected by special condition six of Coastal Development Permit 5-98-156;
- e) All parcels shall conform to all terms and conditions of Coastal Development Permit 5-98-156 as amended; and,
- f) The portion of the project site that is located south of Shoreline Drive, except for the four acres that comprise the proposed commercial parcels, shall remain designated as public park area.

The applicants shall record the final parcel map in accordance with the revised parcel map approved by the Executive Director pursuant to this condition. All development shall take place consistent with the revised parcel map approved by the Executive Director. All terms and conditions of Coastal Development Permit 5-98-156, as amended, shall be attached to the final recorded parcel map.

37. **Permitted Uses.**

The development and use of each parcel created by the proposed parcel map is limited to the development and uses expressly permitted by the terms and conditions of Coastal



Development Permit 5-98-156 as amended. All terms and conditions of Coastal Development Permit 5-98-156, as amended, shall be attached to the final recorded parcel map.

38. **Consistency with State Tidelands Grant.** [*Condition Satisfied 5/5/00*]

Prior to issuance of the coastal development permit amendment (5-98-156-A3), the applicants shall provide written documentation to the Executive Director, including specific citation of the relevant sections of the applicable State Tidelands Grant, specifically demonstrating that the proposed subdivision of State Tidelands is consistent with the terms and conditions of the Legislature's grant of this portion of the Downtown Shoreline to the City of Long Beach. The applicants shall also demonstrate that the State Lands Commission has given permission for the proposed subdivision of State Tidelands and agrees that the proposed subdivision of State Tidelands is consistent with the terms and conditions of the Legislature's grant of this portion of the Downtown Shoreline to the City of Long Beach.

39. **Pedestrian Connection Between LCP Subarea 3 and LCP Subareas 5 & 6.**

The public sidewalk and stairway proposed along the south side of Shoreline Drive connecting the existing public pedestrian access systems in LCP Subarea 3 to LCP Subareas 5 and 6 shall be constructed concurrent with the commercial development approved in LCP Subarea 5. The proposed public sidewalk and stairway linking the existing public pedestrian access systems in LCP Subareas 3, 5 and 6 shall be opened to the general public prior to the date of issuance of the first certificate of occupancy within the development permitted by Coastal Development Permit 5-98-156. Public access along the proposed and existing pedestrian accessways in LCP Subareas 3, 5 and 6 shall remain open and unobstructed for use by the general public. No gate or other obstruction is permitted on any proposed or existing pedestrian accessway in LCP Subareas 3, 5 or 6.

40. **Protection of Water Quality – Project Design & Post Construction.**

PRIOR TO ISSUANCE OF THE PERMIT AMENDMENT, the applicants shall submit for the review and approval of the Executive Director, a Water Quality Management Plan (WQMP) for the post-construction portion of the site subject to Permit Amendment 5-98-156-A6, prepared by a licensed water quality professional. The WQMP shall incorporate structural and non-structural Best Management Practices (BMPs) designed to reduce, to the maximum extent practicable, the volume, velocity and pollutant load of storm water and nuisance flow leaving the developed site. The WQMP shall be in substantial conformance with the following requirements:

A. Water Quality Goals.

- (i) Appropriate structural and non-structural BMPs shall be designed to treat, infiltrate, or filter the runoff from all surfaces and activities on the development site.
- (ii) Post-construction structural BMPs (or suites of BMPs) should be designed to treat, infiltrate or filter the amount of storm water runoff produced by all storms up to and including the 85th percentile, 24-hour storm event for volume-based BMPs, and/or the

85th percentile, 1-hour storm event, with an appropriate safety factor (i.e., 2 or greater), for flow-based BMPs.

- (iii) Runoff from all roofs, parking areas, maintenance areas, and driveways shall be collected and directed through a system of appropriate structural BMPs. The filter elements shall be designed to 1) trap sediment, particulates and other solids and 2) remove or mitigate contaminants through filtration and/or biological uptake. The drainage system shall also be designed to convey and discharge runoff in excess of this standard from the building site in a non-erosive manner.

**B. Restaurants**

- (i) Each restaurant shall have a wash down area for restaurant equipment and accessories which shall be designed as follows: a) Designate equipment-cleaning areas indoors, and install berms to direct all runoff to the sewer system; or, if equipment cleaning areas are to be located outdoors, all wash-down areas shall be routed to the sanitary sewer system and shall not contribute to polluted runoff or nuisance flows; b) Prohibit the cleaning of equipment in any area where water may flow to a street, gutter, creek, or storm drains; and, c) Minimize to the maximum extent practicable the amount of wash water used.
- (ii) The above restriction on restaurants shall be incorporated into a lease agreement with the concessionaire or operator of such facilities so that such requirements are binding upon them.

**C. Education and Training**

- (i) Provide annual training of employees on chemical management and proper methods of handling and disposal of waste. Make sure all employees understand the on-site BMPs and their maintenance requirements.
- (ii) Provide informational signs around the establishment for customers and employees about water quality and the BMPs used on-site.
- (iii) Label/stencil outdoor drains to indicate whether they flow to an on-site treatment device, a storm drain, or the sanitary sewer as appropriate.

**D. Landscaping.** Minimize to the maximum extent practicable the use of pesticides and fertilizers.

**E. Monitoring and Maintenance**

- (i) All BMPs shall be operated, monitored, and maintained for the life of the project and at a minimum, all structural BMPs shall be inspected, cleaned-out, and where necessary, repaired, at the following minimum frequencies: 1) prior to October 15th each year; 2)

during each month between October 15<sup>th</sup> and April 15<sup>th</sup> of each year and, 3) at least twice during the dry season (between April 16 and October 14 of every year).

- (ii) Debris and other water pollutants removed from structural BMP(s) during clean-out shall be contained and disposed of in a proper manner.
- (iii) It is the applicants' responsibility to maintain the drainage system and the associated structures and BMPs according to manufacturer's specification and to ensure maximum pollutant removal efficiencies.

The permittees shall undertake and maintain the approved development in accordance with the Water Quality Management Plan approved by the Executive Director pursuant to this condition. Any proposed changes to the approved Water Quality Management Plan shall be reported to the Executive Director in order to determine if the proposed change shall require a permit amendment pursuant to the requirements of the Coastal Act and the California Code of Regulations. No changes to the approved plan shall occur without a Commission amendment to this coastal development permit unless the Executive Director determines that no amendment is required.

**41. Permitted Use: Overnight Room Rentals.**

The permitted use of the structure approved by Coastal Development Permit Amendment 5-98-156-A15 is a 140-room hotel (as defined in the certified City of Long Beach Local Coastal Program - Zoning Code Section 21.15.1380). The approved structure shall be operated as a bona fide hotel that provides overnight accommodations to visitors for a period of not more than thirty consecutive days. Any change in the number of units or change in use (including, but not limited to, a change from overnight room rentals to time shares or month-to-month rentals) is not permitted by this action and shall be submitted to the Executive Director to determine whether an amendment to this permit is necessary pursuant to the requirements of the Coastal Act and the California Code of Regulations.

**42. Permitted Use: Overnight Room Rentals.**

The permitted use of the structure approved by Coastal Development Permit Amendment 5-98-156-A17 is a 125-room hotel (as defined in the certified City of Long Beach Local Coastal Program - Zoning Code Section 21.15.1380) with 14,725 square feet of ground-floor retail space. The approved 125-room hotel shall be operated as a bona fide hotel that provides overnight accommodations to visitors for a period of not more than thirty consecutive days. Any change in use from overnight room rentals to time shares, condominium-style hotel rooms, or month-to-month rentals is not permitted by this action and is prohibited on the project site as such uses are not recognized as legal uses of State Tidelands. Any proposed change to the approved development shall be submitted to the Executive Director to determine whether an amendment to this permit is necessary pursuant to the requirements of the Coastal Act and the California Code of Regulations.

43. **Affordable Overnight Accommodations – Mitigation.**

(a) A \$30,000 mitigation fee per room shall apply to 25% of the total number of approved hotel rooms (0.25 x 125). Prior to the commencement of construction of the approved development, the total in-lieu fee of \$937,000 ( $\$30,000 \times 31.25 = \$937,500$ ) shall be deposited into an interest-bearing account, to be established and managed by the State Coastal Conservancy pursuant to a memorandum of understanding entered into between the Conservancy and the Executive Director. The purpose of this account shall be to provide funding grants to public agencies or non-profit organizations for the provision of lower cost overnight visitor accommodations within or in close proximity to the coastal zone, including but not limited to hostel accommodations, campground accommodations, cabins, or low cost hotel or motel accommodations.

(b) The entire fee deposited into the special account identified in subparagraph (a) together with any accrued interest shall be used for the purpose set forth in subparagraph (a), and the expenditure of any funds from this account shall be subject to review and approval by the Executive Director of the Coastal Commission. This fee shall be expended within five (5) years of the date the fee is deposited into the account, unless this time limit is extended for good cause for a period not to exceed an additional five (5) years. If the funds are not expended within this time period, the Commission and the State Conservancy shall agree on an alternative expenditure of the funds for public recreational benefits in the coastal zone.

44. **Final Parking Management Plan.** *[Imposed by Commission Approval of 5-98-156-A16 and As Revised by Commission Approval of 5-98-156-A20]*

PRIOR TO ISSUANCE OF COASTAL DEVELOPMENT PERMIT AMENDMENT 5-98-156-A16, the co-permittees shall submit, for the review and approval of the Executive Director, a final parking management plan describing and showing the location and height of all structures approved by this permit amendment and approved by Coastal Development Permit 5-98-156, as previously amended, including, but not limited to:

- a) The valet stand located at the terminus of South Pine Avenue showing that the valet stand has either been moved out of the view corridor or has been redesigned to comply with Special Condition 19's height restrictions;
- b) The valet stand and waiting areas located adjacent to Building J;
- c) The valet stand located within the surface lot;
- d) All signs located within the surface lot, including the content of all signs describing the parking rules and rates within the lot;
- e) Thirteen (13) stalls in the northwest corner of the Surface Lot to be set aside for valet parking;

- f) Twelve (12) waterfront, short-term parking stalls to be available for self-parking at all times;
- g) Thirty-three (33) new metered on-street parking spaces along Shoreline Drive (pursuant to 5-98-156-A20); and
- h) Thirty-seven (37) new metered on-street parking spaces along Shoreline Drive.

The final parking management plan shall be in substantial conformance with the development and management plan approved pursuant to Coastal Development Permit No. 5-98-156, as amended and as specifically described in the staff report dated 2/19/15 (Revised Findings for 5-98-156-A16). The co-permittees shall undertake and maintain the development in conformance with the special conditions of the permit and the final plans approved by the Executive Director. Any proposed changes to the approved plans shall be reported to the Executive Director in order to determine if the proposed change shall require a permit amendment pursuant to the requirements of the Coastal Act and the California Code of Regulations. No changes to the approved plans shall occur without a Commission-approved permit amendment unless the Executive Director determines that no permit amendment is required.

45. **Bird-safe Building Requirements.** *[Imposed by Commission Approval of 5-98-156-A18]*

All new buildings and renovations of existing buildings shall be required to provide bird-safe building treatments for the facades, railings, landscaping, and lighting consistent with the guidelines provided below:

a. Glazing treatments:

- Fritting, permanent stencils, frosted, non-reflective or angled glass, exterior screens, decorative latticework or grills, physical grids placed on the exterior of glazing, or UV patterns visible to birds shall be used to reduce the amount of untreated glass or glazing to less than thirty-five percent (35%) of the building façade.
- Where applicable vertical elements within the treatment pattern should be at least one-quarter inch (1/4") wide at a maximum of spacing of four inches (4") and horizontal elements should be at least one-eighth inch (1/8") wide at a maximum spacing of two inches (2").
- No glazing shall have a "Reflectivity Out" coefficient exceeding thirty percent (30%). That is, the fraction of radiant energy that is reflected from glass or glazed surfaces shall not exceed thirty percent (30%).
- Equivalent treatments recommended by a qualified biologist may be used if approved by the City and/or the Coastal Commission.

b. Lighting Design:

- Nighttime lighting shall be minimized to levels necessary to provide pedestrian security.
- Buildings shall be designed to minimize light spillage and maximize light shielding to the maximum feasible extent.

- Building lighting shall be shielded and directed downward. Up-lighting shall be prohibited. Use of “event” searchlights or spotlights shall be prohibited.
- Landscape lighting shall be limited to low-intensity and low-wattage lights.
- Red lights shall be limited to only that necessary for security and safety warning purposes.

c. Landscaping:

- Trees and other vegetation shall be sited so that the plants are not reflected on building surfaces.
- In order to obscure reflections, trees and other vegetation planted adjacent to a reflective wall or window shall be planted close to (no further than three feet from) the reflective surface.
- For exterior courtyards and recessed areas, building edges shall be clearly defined by using opaque materials or non-reflective glass.
- Walkways constructed of clear glass shall be minimized. Where permitted, they shall utilize fritting, permanent stencils, frosted, non-reflective or angled glass, exterior screens, decorative latticework or grills, physical grids placed on the exterior of glazing, or UV patterns visible to birds.

d. Building Interiors

- Light pollution from interior lighting shall be minimized through the utilization of automated on/off systems and motion detectors.

e. Lights Out for Birds

- The City shall encourage building owners and operators to participate in “Lights Out for Birds” programs or similar initiatives by turning off lighting at night, particularly during bird migration periods.

46. **Final Site Plan.** *[Imposed by Commission Approval of 5-98-156-A18]*

PRIOR TO ISSUANCE OF COASTAL DEVELOPMENT PERMIT AMENDMENT 5-98-156-A18, the applicants shall submit for the review and approval of the Executive Director, a final site plan, showing the location, height, and material of all structures approved by this permit amendment and approved by Coastal Development Permit 5-98-156, as amended, including but not limited to:

- a) The landscaping and drainage for the entire site;
- b) All expanded exterior facades and stairways;

- c) The bike repair station;
- d) The pedestrian bridge between the Pike Parking Structure to Building E; and
- e) The exterior dining patio of Building G1.

The plans shall be in substantial conformance with the development approved pursuant to Coastal Development Permit 5-98-156, as amended and as specifically described in the staff report dated 10/23/14. The co-permittees shall undertake and maintain the development in conformance with the special conditions of the permit and the final plans approved by the Executive Director. Any proposed changes to the approved plans shall be reported to the Executive Director in order to determine if the proposed change shall require a permit amendment pursuant to the requirements of the Coastal Act and the California Code of Regulations. No changes to the approved plans shall occur without a Commission-approved permit amendment unless the Executive Director determines that no permit amendment is required.

**47. Additional Public Parking - Subarea 6.** *[Imposed by Commission Approval of 5-98-156-A16 and As Revised by Commission Approval of 5-98-156-A20]*

Prior to the construction and implementation of improvements to the valet parking program within the public parking lot located in Shoreline Park at the southwest corner of Shoreline Drive and South Pine Avenue (surface lot) described in Coastal Development Permit Amendment 5-98-156-A16, the co-permittees shall construct and open for public use a total of seventy (70) metered on-street public parking spaces along Shoreline Drive as depicted in the final plans submitted pursuant to Special Condition 44. The metered stalls shall be posted for "Four-hour Parking." The cost for parking in the metered stalls shall conform to the rates authorized by the Commission and/or Executive Director for the Downtown Shoreline area.

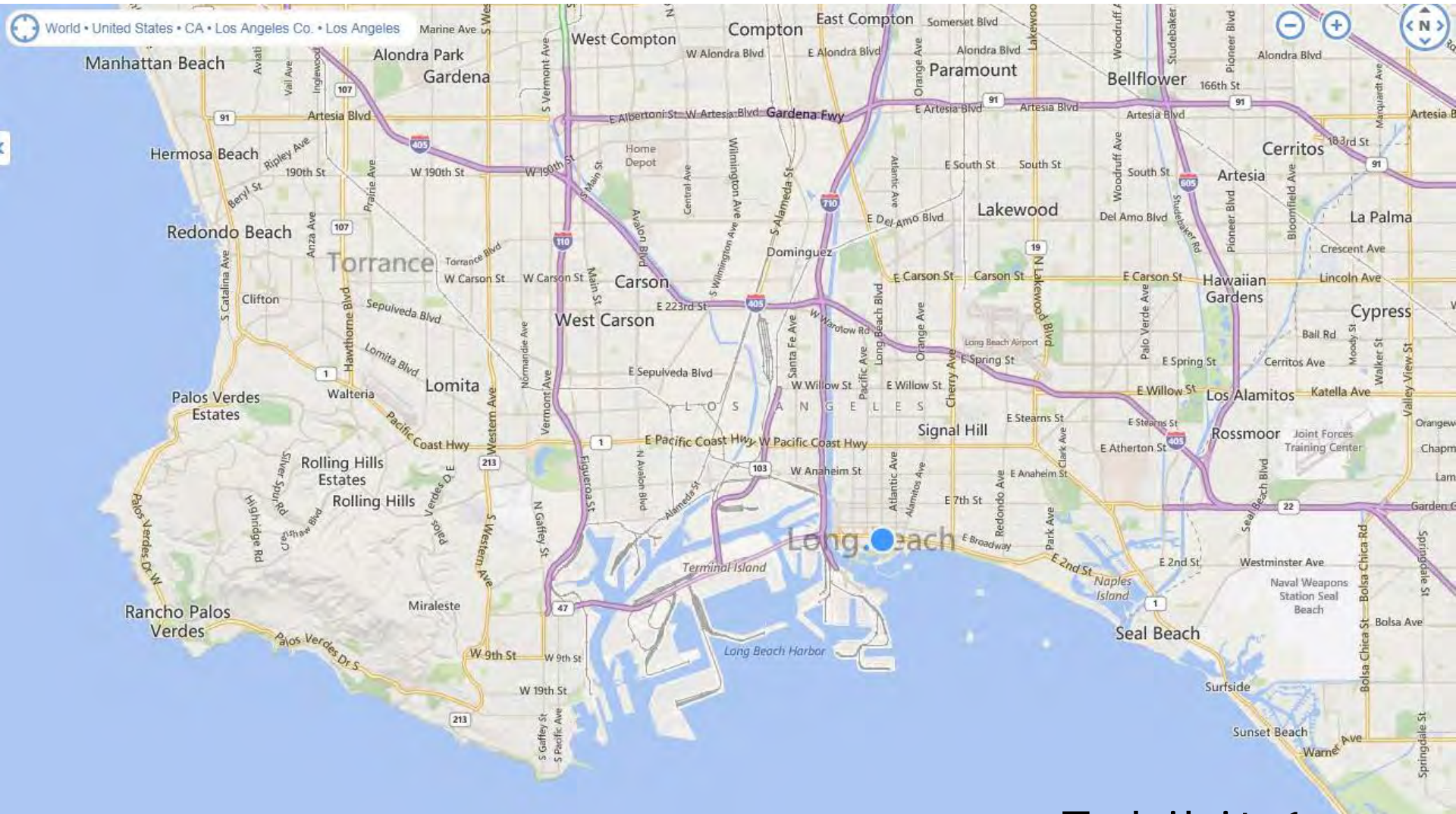







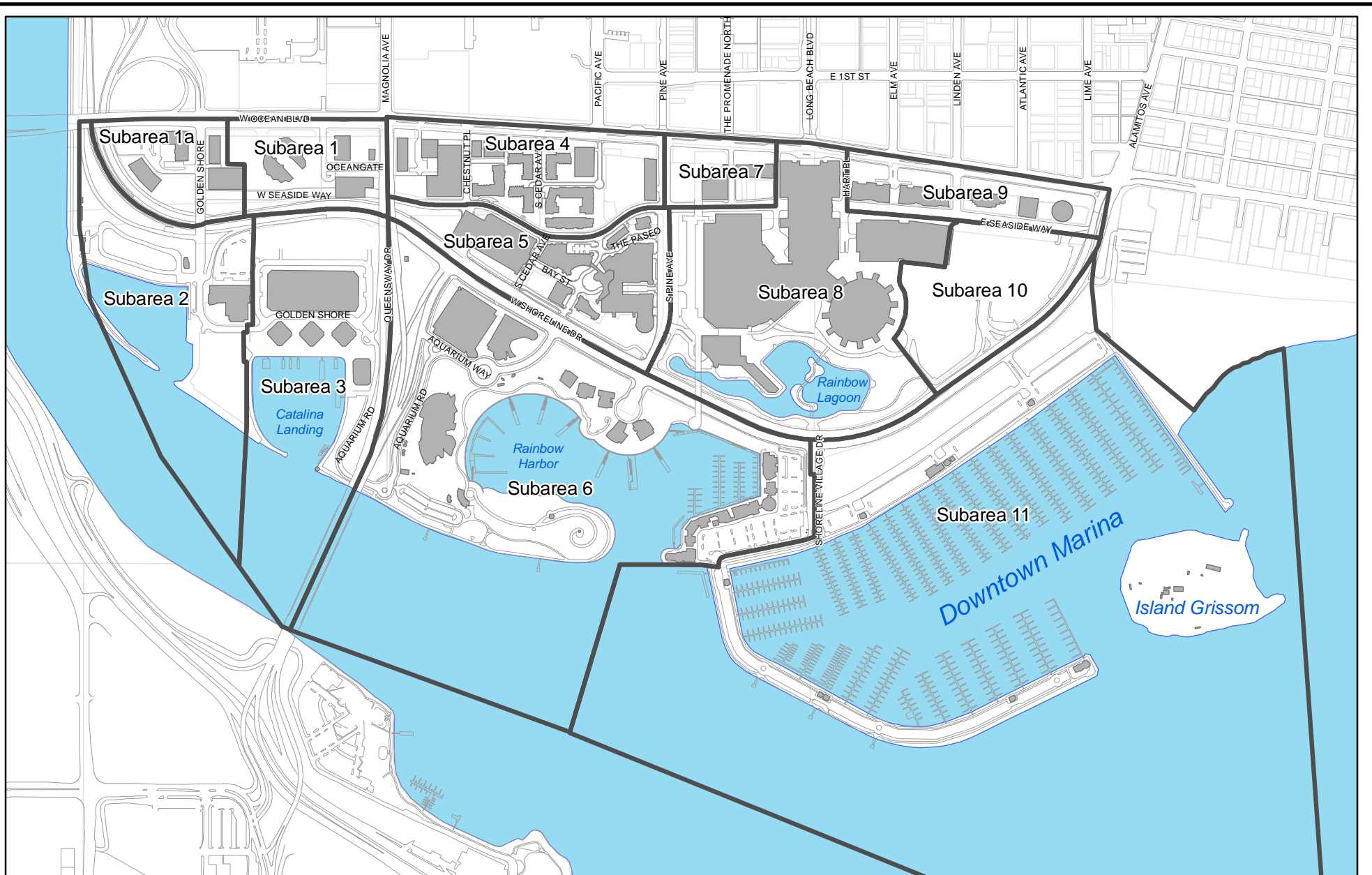

Downtown Shoreline  
 Planned Development District  
 (PD-6)

Updated March 2011

Exhibit 2   
 Page 1 of 1

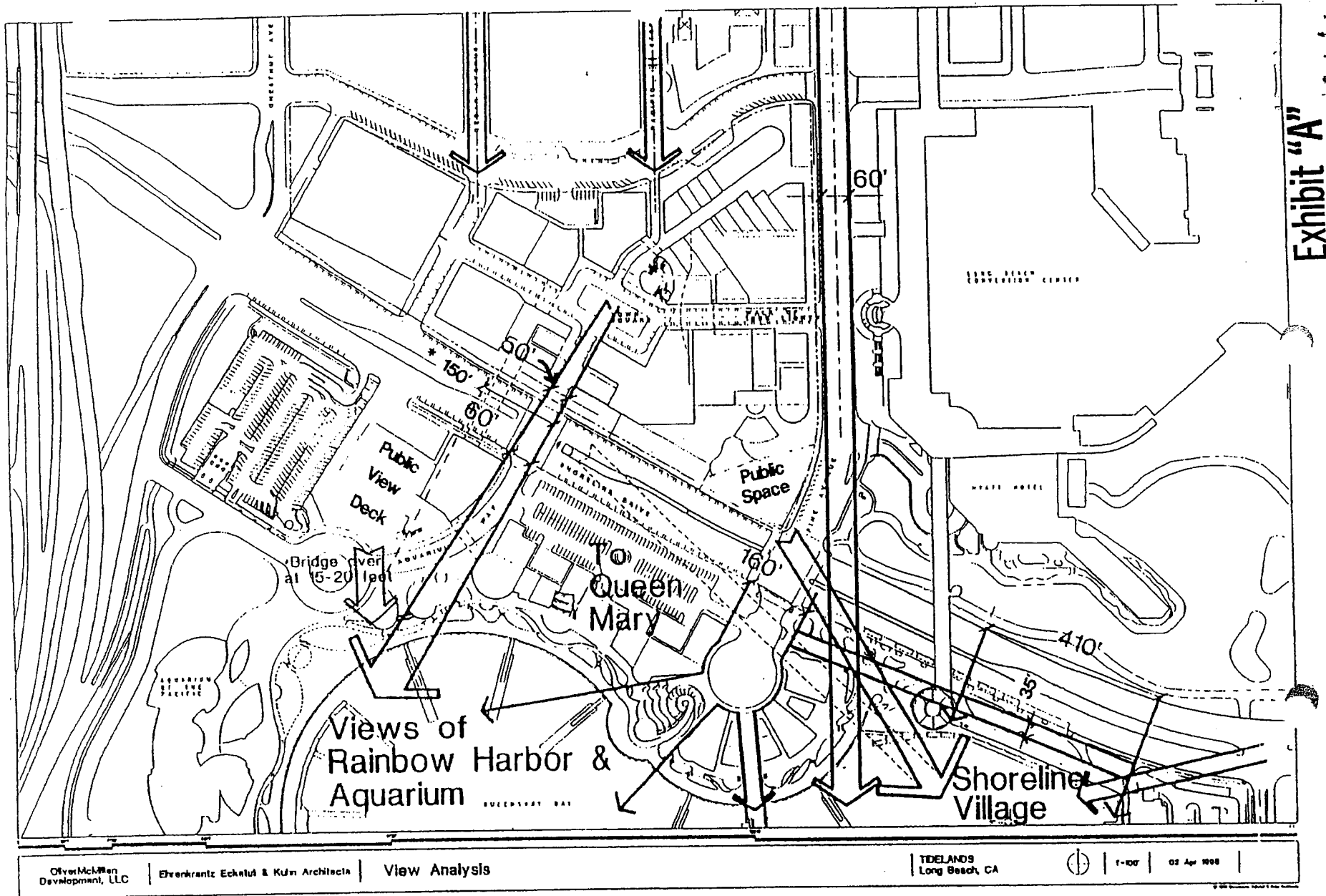
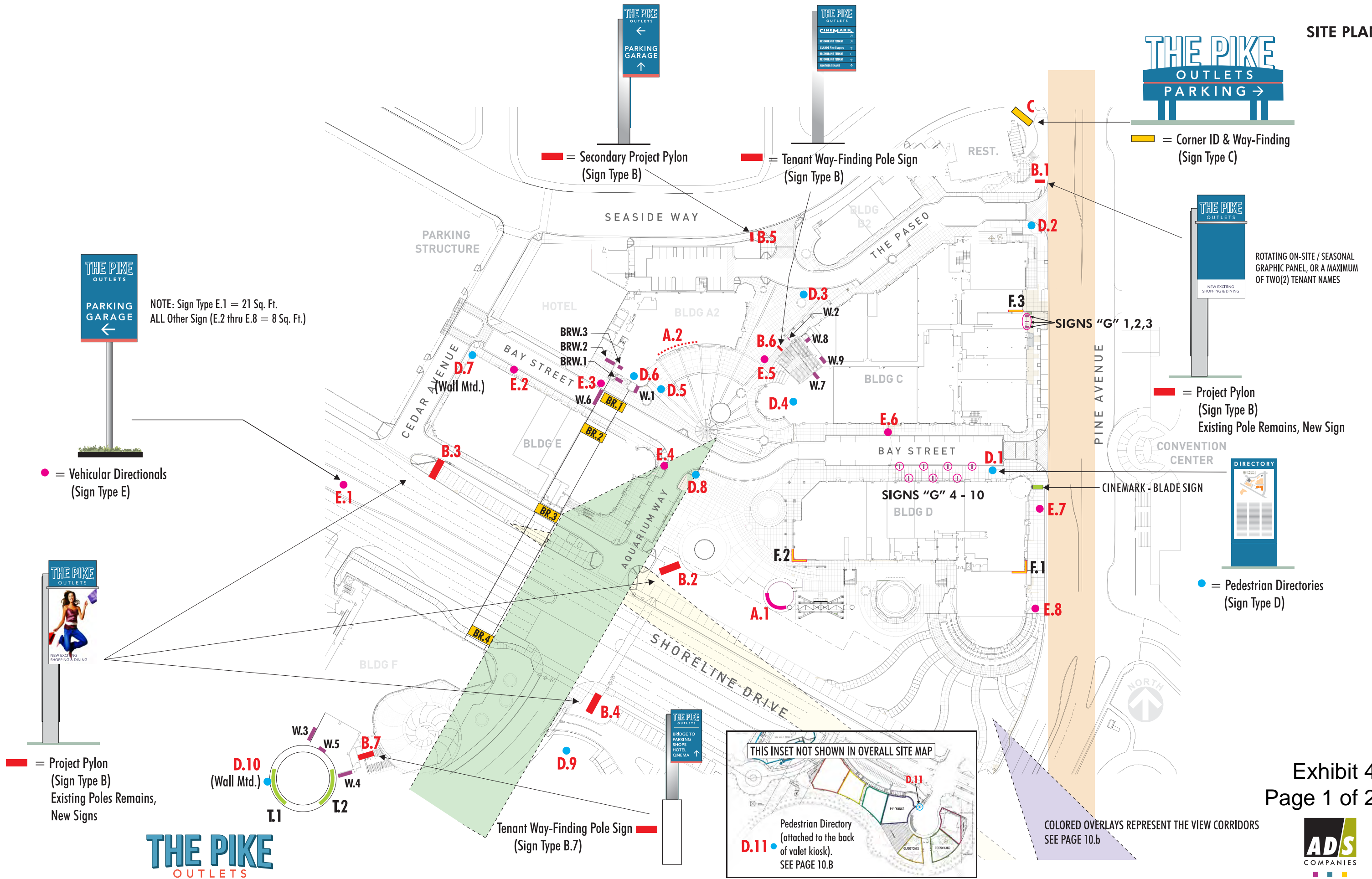

Exhibit "A"

## PD 6 Attachment "A" - View Corridors

\*150' wide view corridor or 60' corridor, and 25' wide pedestrian bridge, and 35,000 sq. ft. public viewing deck.



**THE PIKE**  
OUTLETS

NOTE: Sign Type E.1 = 21 Sq. Ft.  
ALL Other Sign (E.2 thru E.8 = 8 Sq. Ft.)

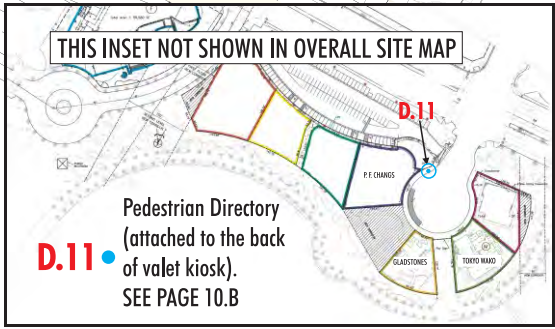



**SITE PLAN  
WITH VIEW CORRIDORS**

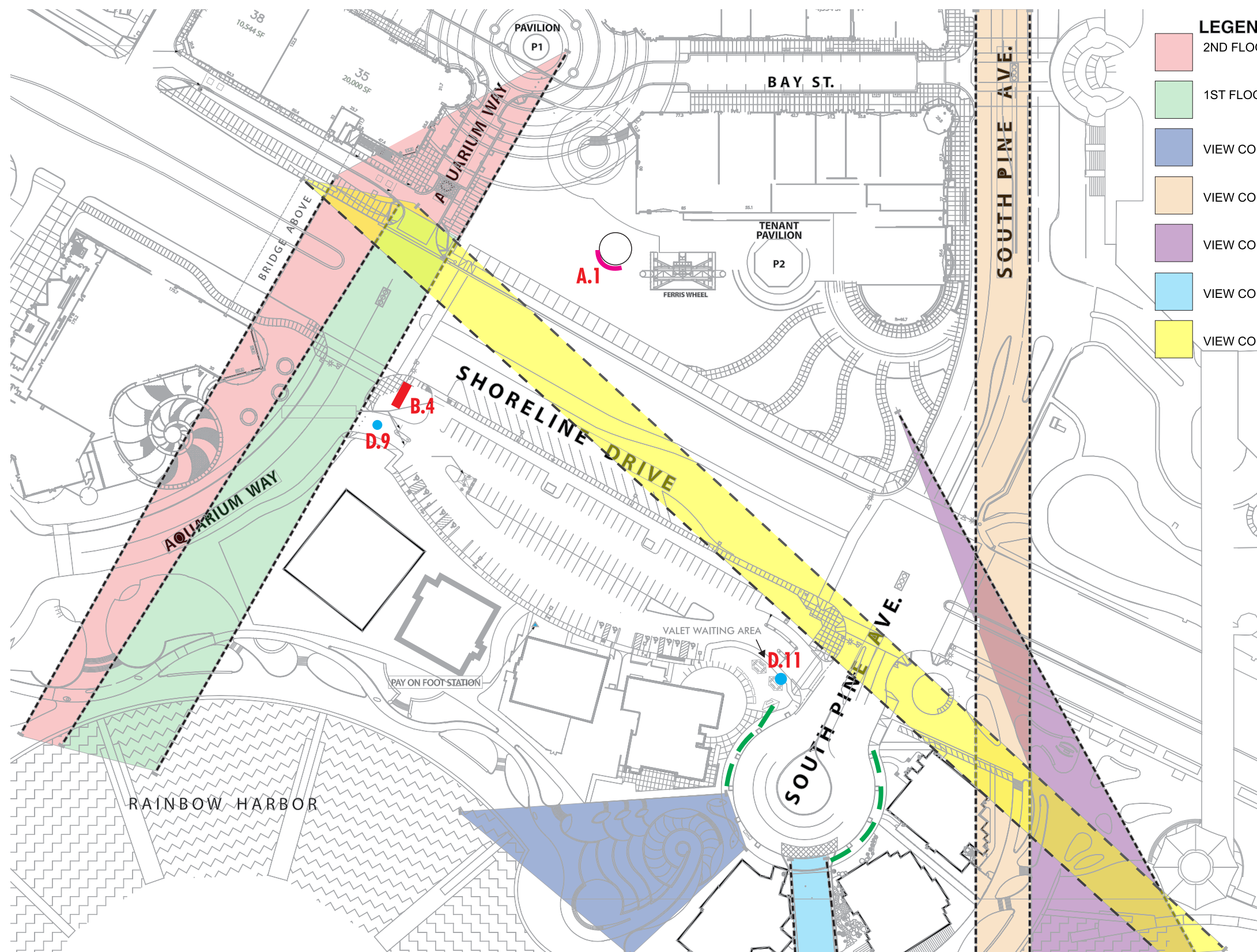

- LEGEND:**
- 2ND FLOOR VIEW CORRIDOR
  - 1ST FLOOR VIEW CORRIDOR
  - VIEW CORRIDOR
  - VIEW CORRIDOR
  - VIEW CORRIDOR
  - VIEW CORRIDOR
  - VIEW CORRIDOR

CONVENTION  
CENTER

NOTE: ALL SIGNS SHOWN ON SITE PLANS ON PAGES 10.A AND 10.B COMPLIES WITH THE PD-6/LCP VIEW CORRIDORS

**A.1**

ICONIC PROJECT IDENTIFICATION SIGN  
COVERING THE RETAINER WALL SURROUNDING  
THE EXISTING ELECTRICAL BOXES

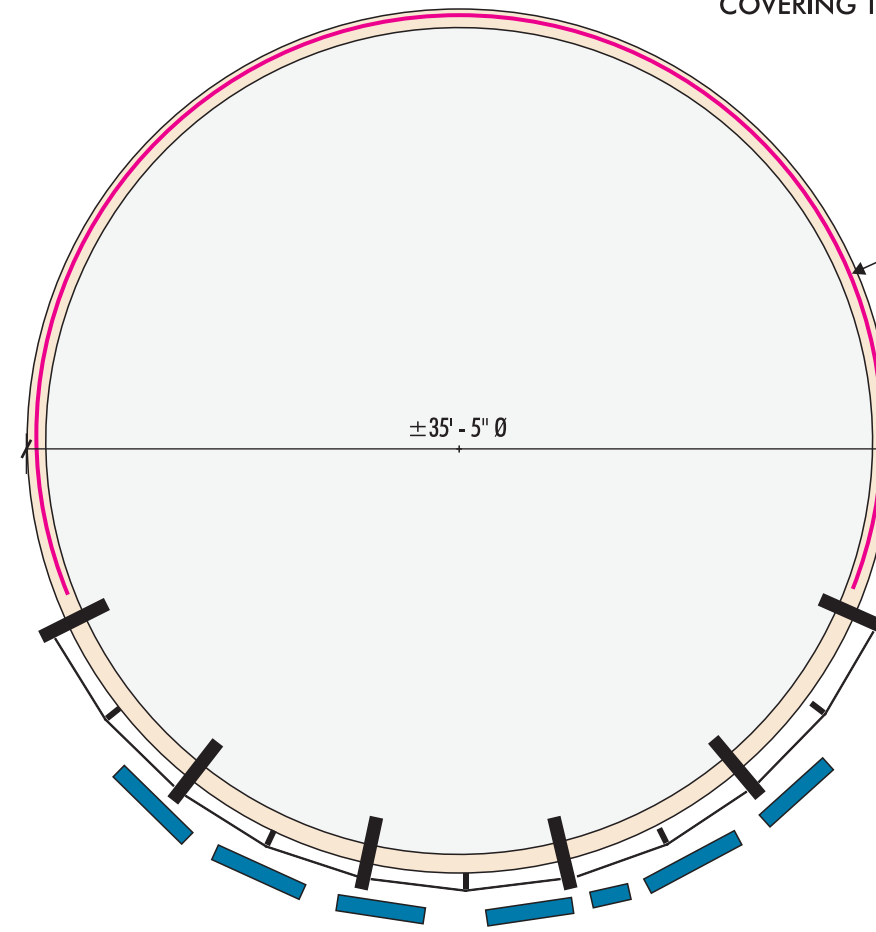

OPTIONAL LIFESTYLE BANNERS TO  
BE CONSIDERED AROUND THE BACK  
AND SIDES OF THE STRUCTURE.

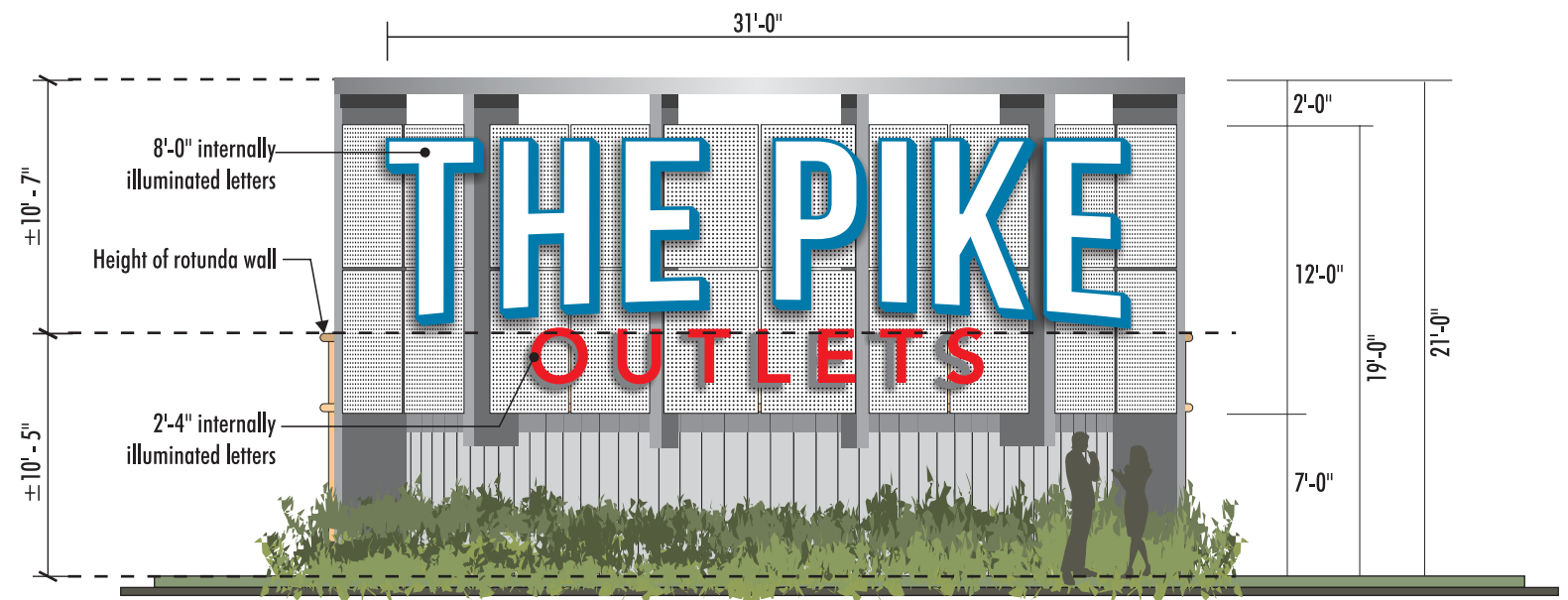



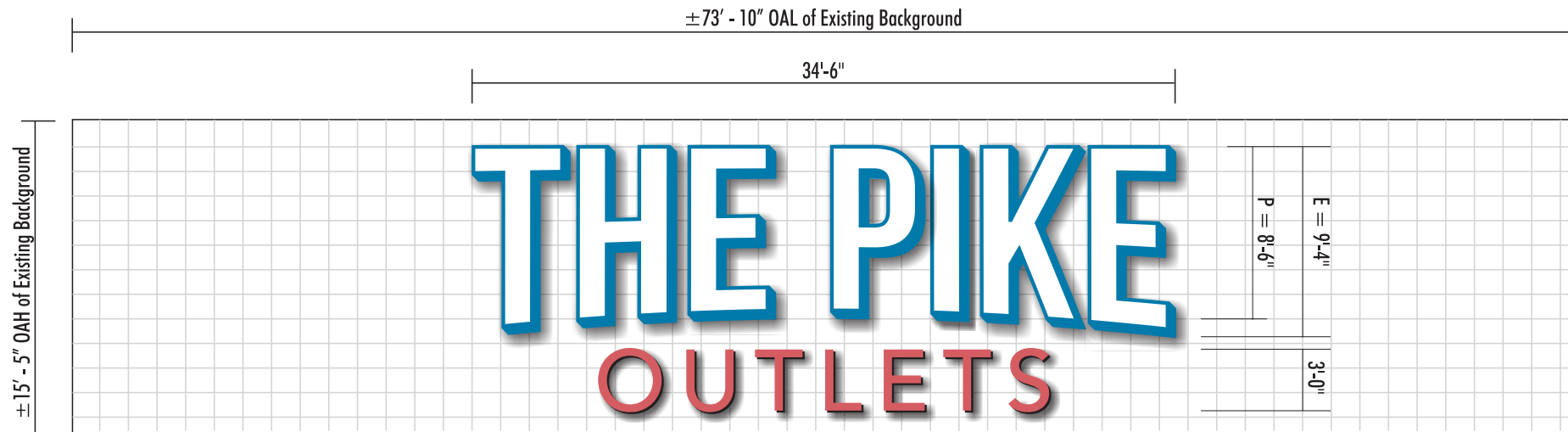
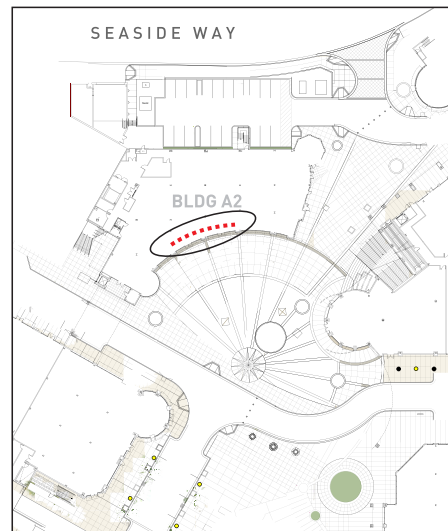
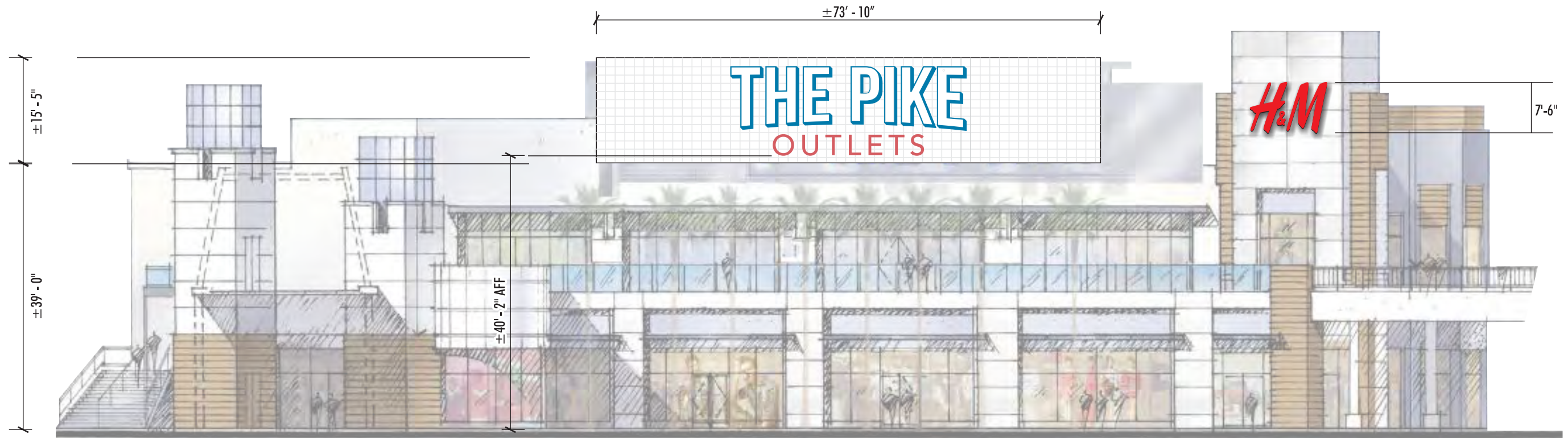

SCALE: 1/8" = 1'-0"

ALL ILLUMINATED CHANNEL LETTERS - FINAL ILLUMINATION LED AND EXPOSED NEON MOUNTED ONTO EXISTING BACKGROUND.

**B.1, B.2, B.3, B.4**  
**PROJECT PYLON WITH ROTATING HIGHLIGHT SIGNAGE.**  
**TO BE USED TO HIGHLIGHT THE FOLLOWING;**  
**TENANTS, (MAXIMUM 2 PER SIGN SIDE), THE CENTER**  
**OR HISTORICAL/CONTEMPORAY IMAGES OF THE PIKE AND THE LONG BEACH SHORELINE**

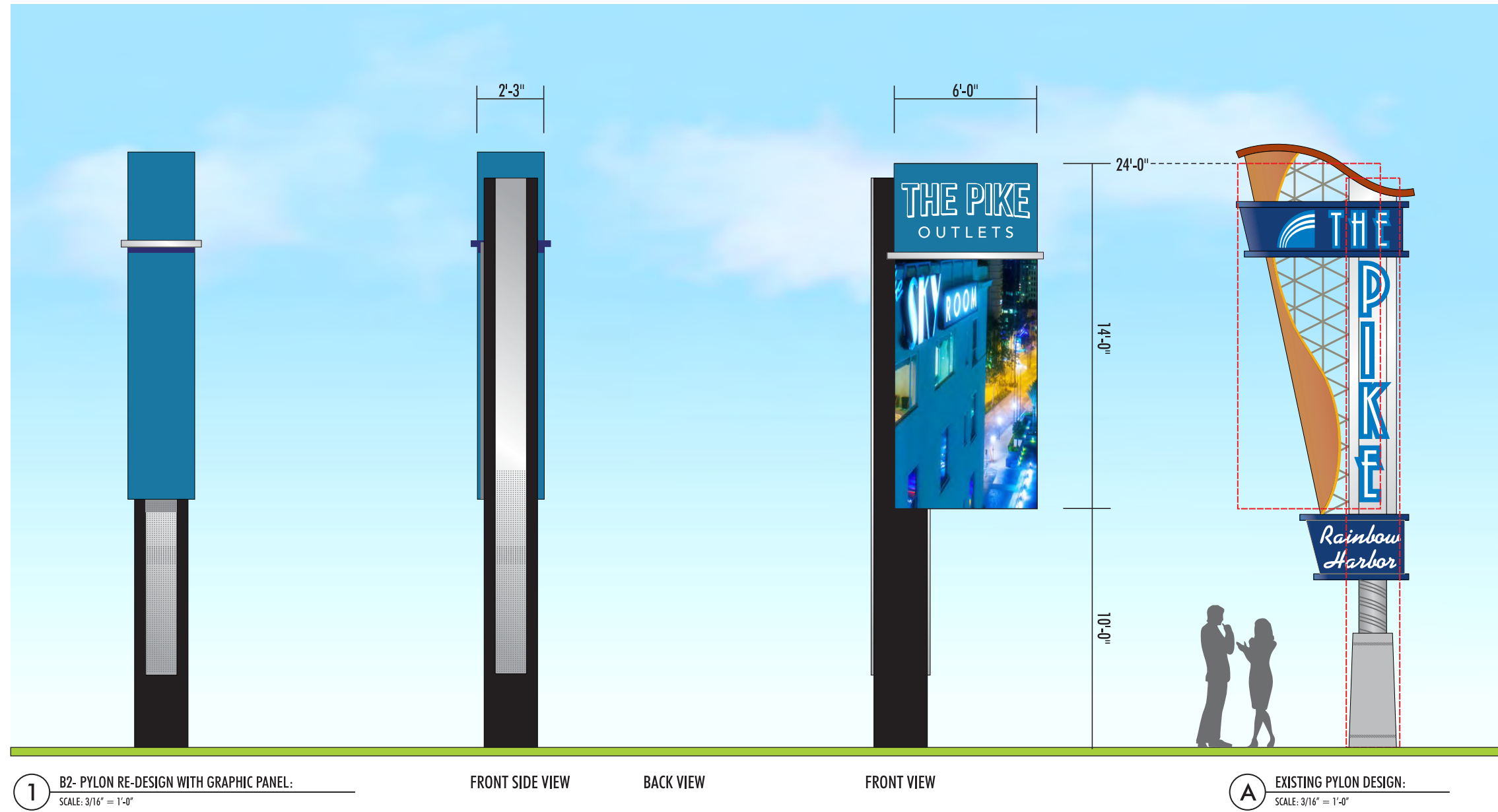



**B.5**  
**SECONDARY PROJECT PYLON**

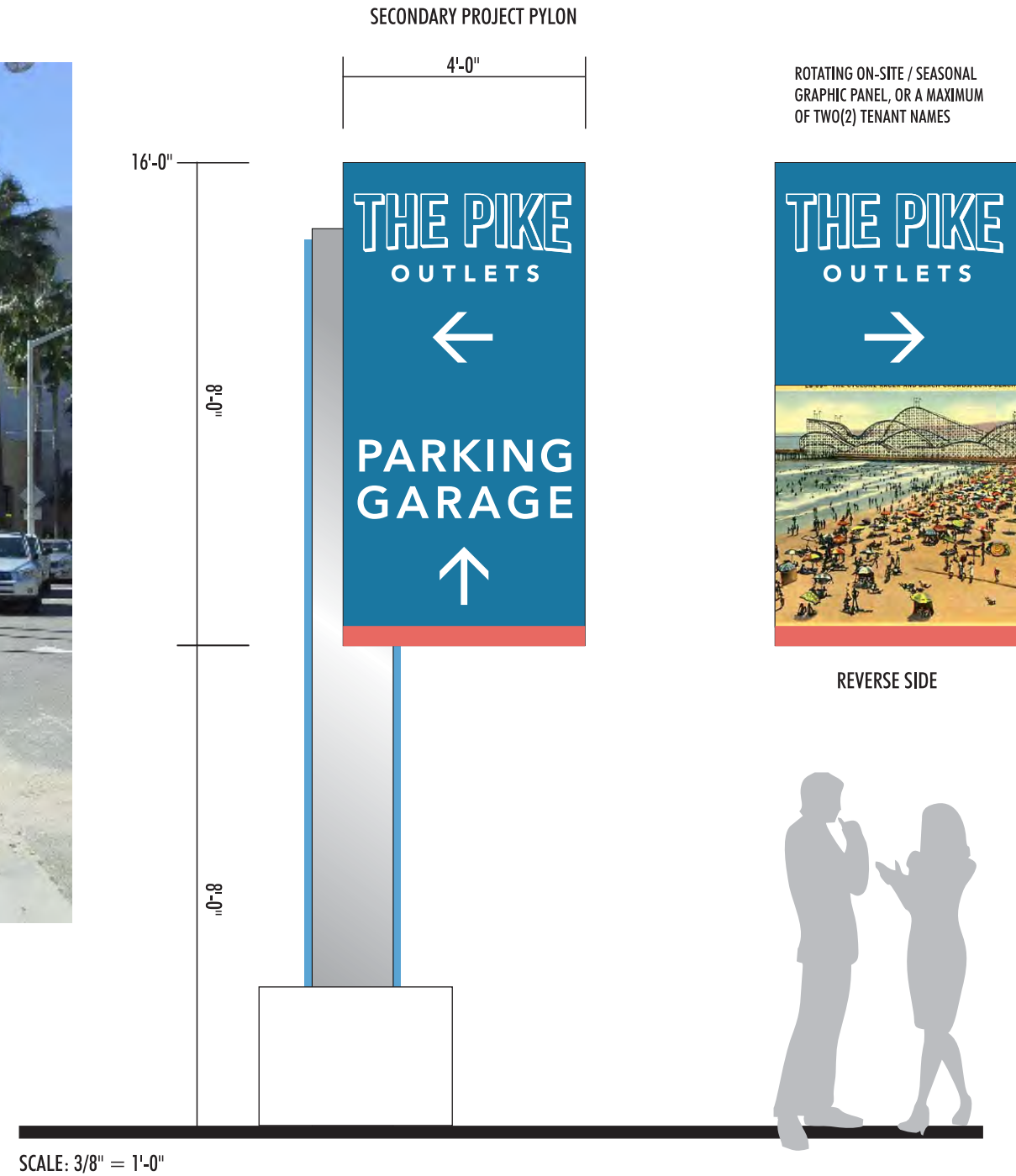

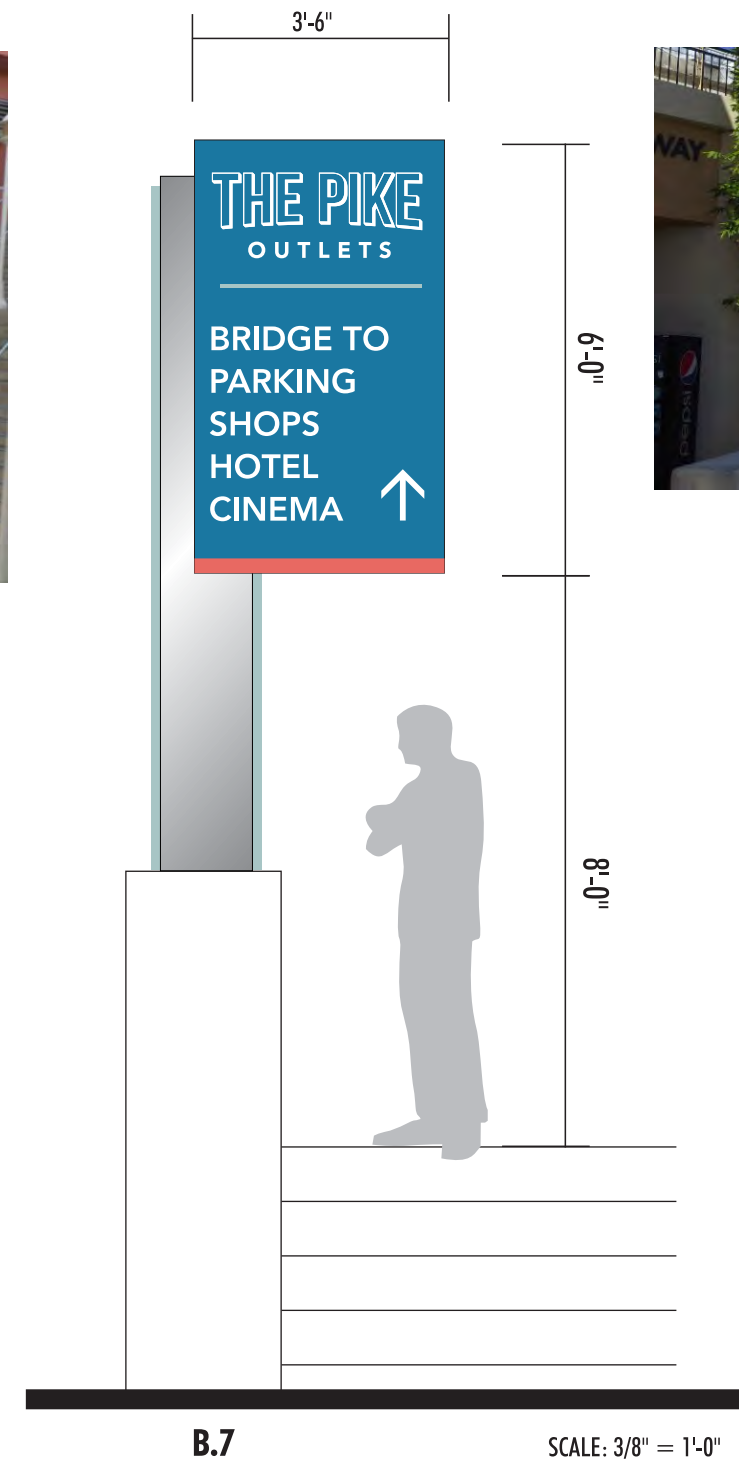
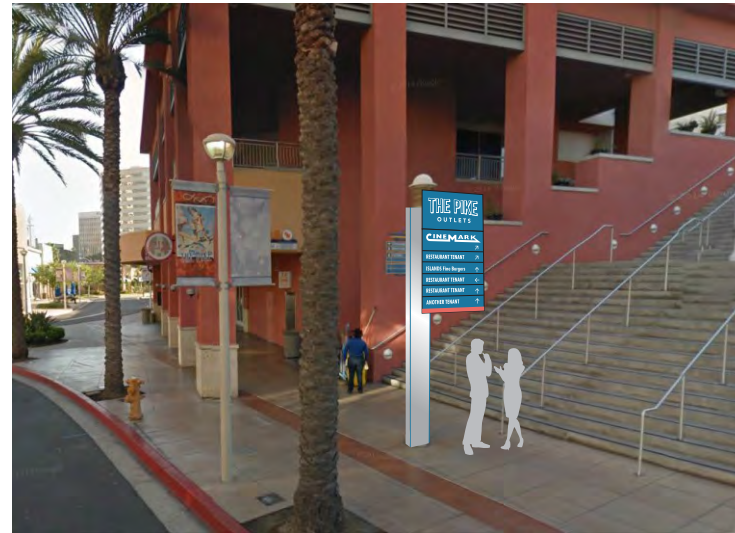
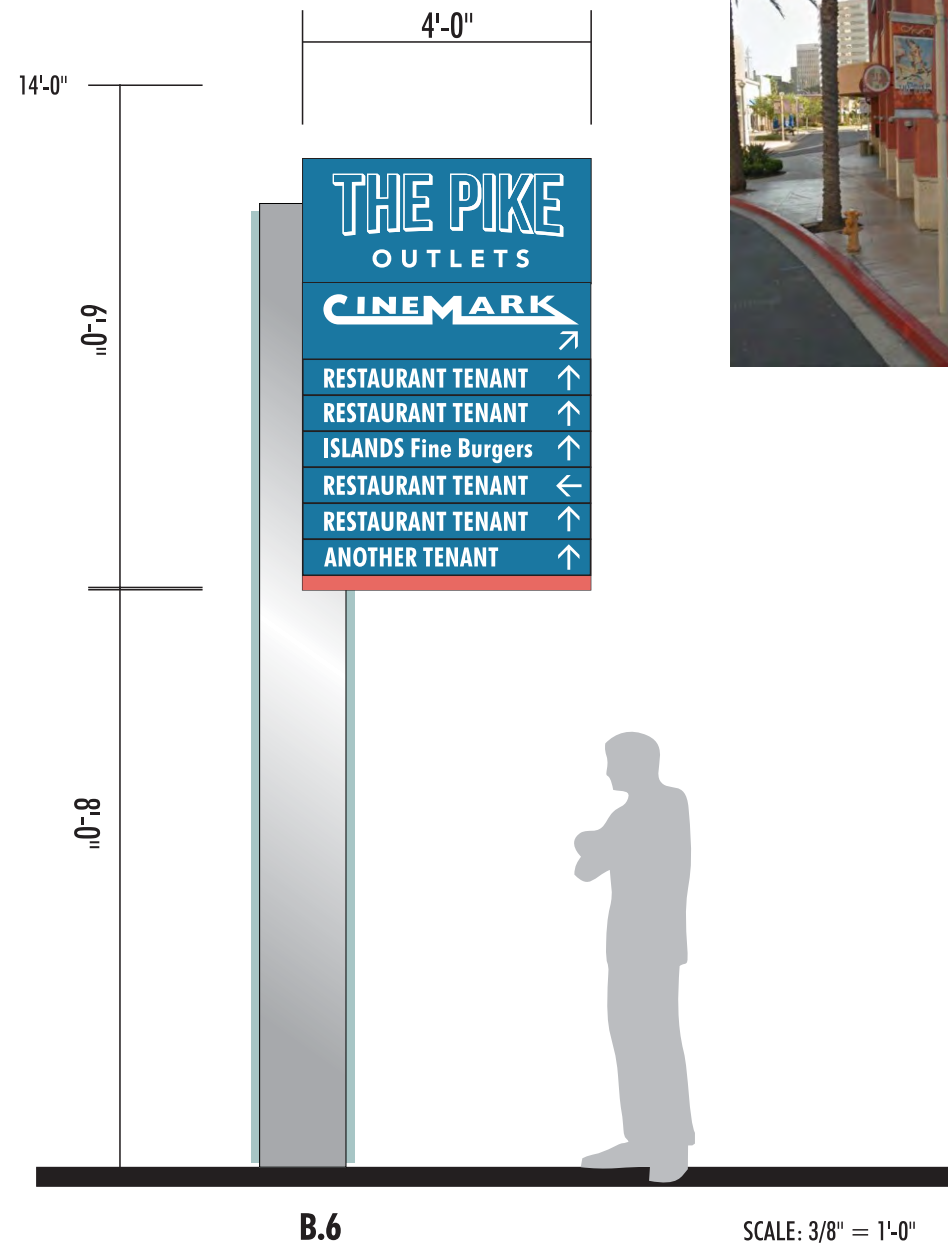



C. CORNER ID AND WAY-FINDING

E. VEHICULAR DIRECTIONAL



SOUTHWEST CORNER OF PINE AVE. & SEASIDE WAY



WEST BOUND SHORELINE DRIVE

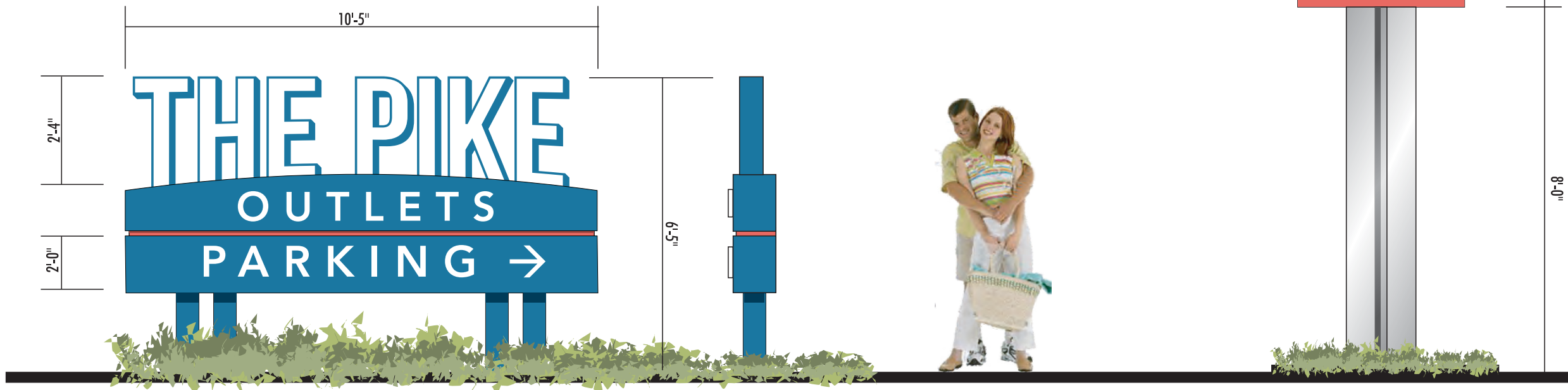

"C" CORNER PARKING WAY FINDING

SCALE: 3/8" = 1'-0"

SIDE VIEW

"E" MEDIAN WAY FINDING

SCALE: 3/8" = 1'-0"

NOTE:

This median way finding sign requires permit issuance from the Public Works Department and review by Traffic Engineering

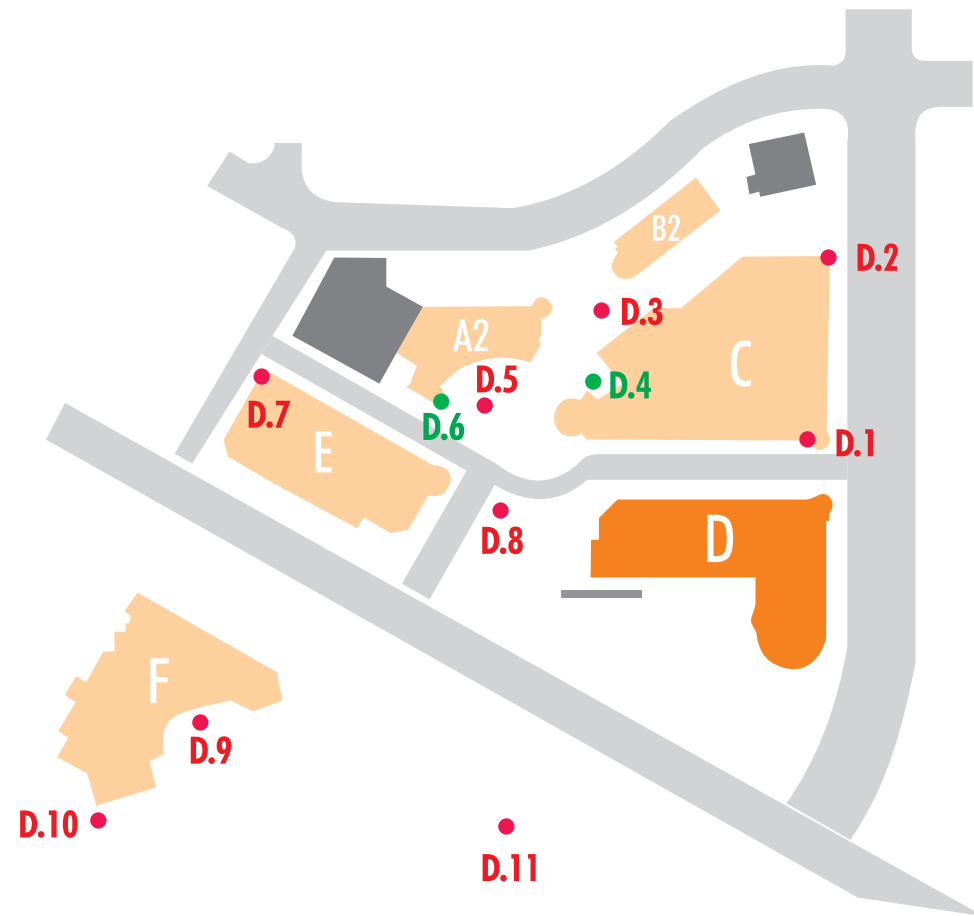

- DIRECTORIES ON UPPER LEVEL
- DIRECTORIES ON LOWER LEVEL

1 INTERNAL LED ILLUMINATED DIRECTORY  
SCALE: 3/4" = 1'-0"

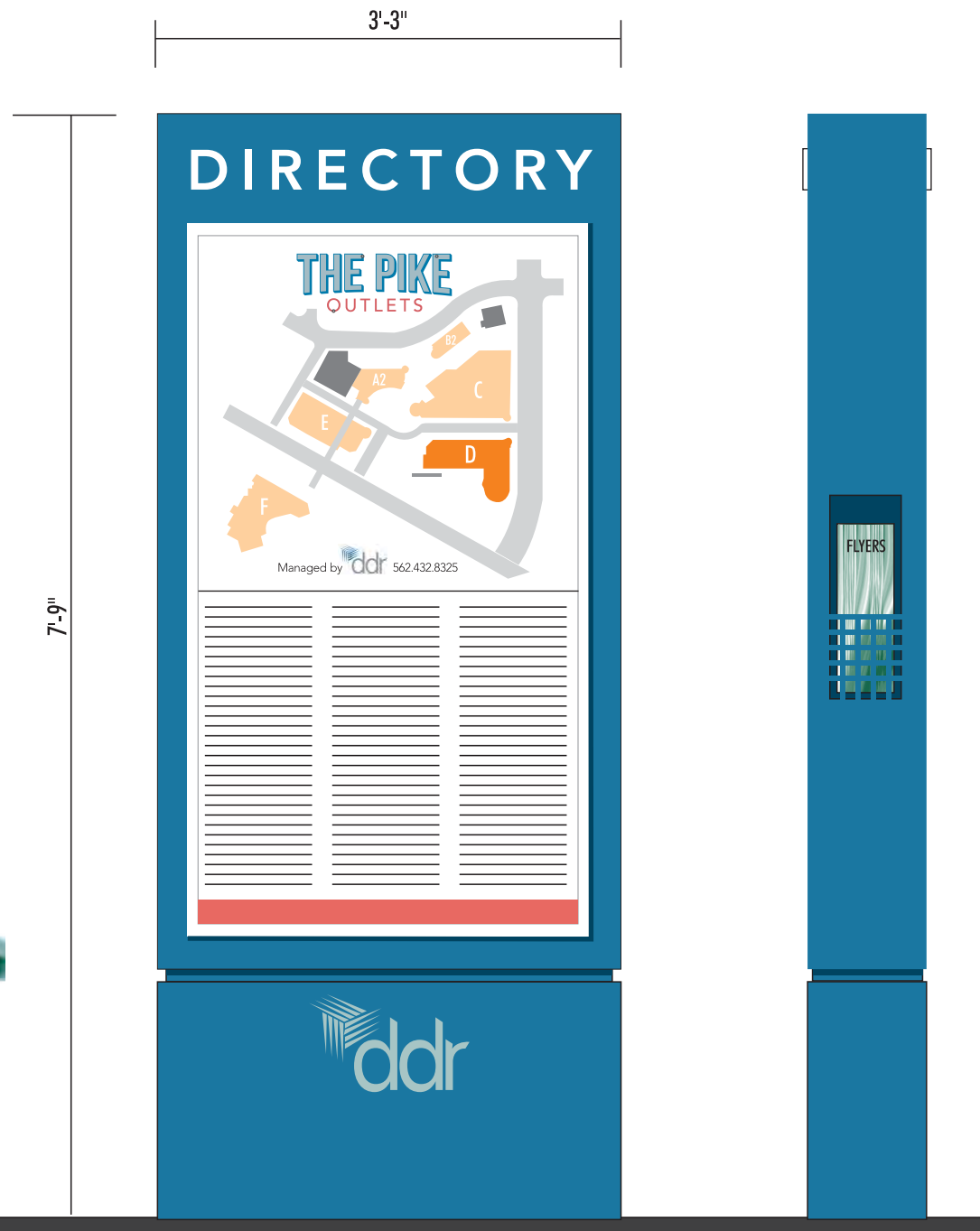



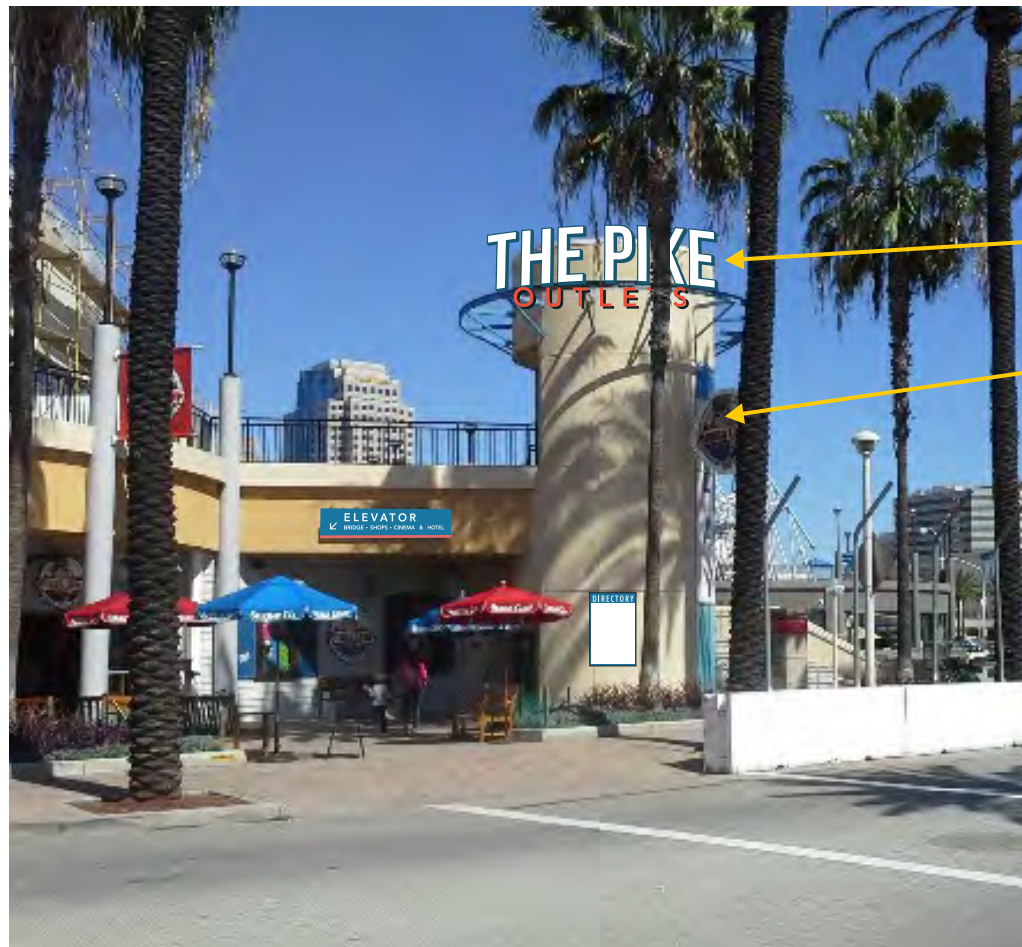

NOTE:  
"THE PIKE" SIGNS ARE  
NEW PROPOSED SIGNS.

"BUBBA GUMP" IS AN  
EXISTING SIGN



T.1

T.2



SCALE: 3/4" = 1'-0"

INTERNALLY ILLUMINATED CHANNEL LETTERS  
68 SQ. FT.

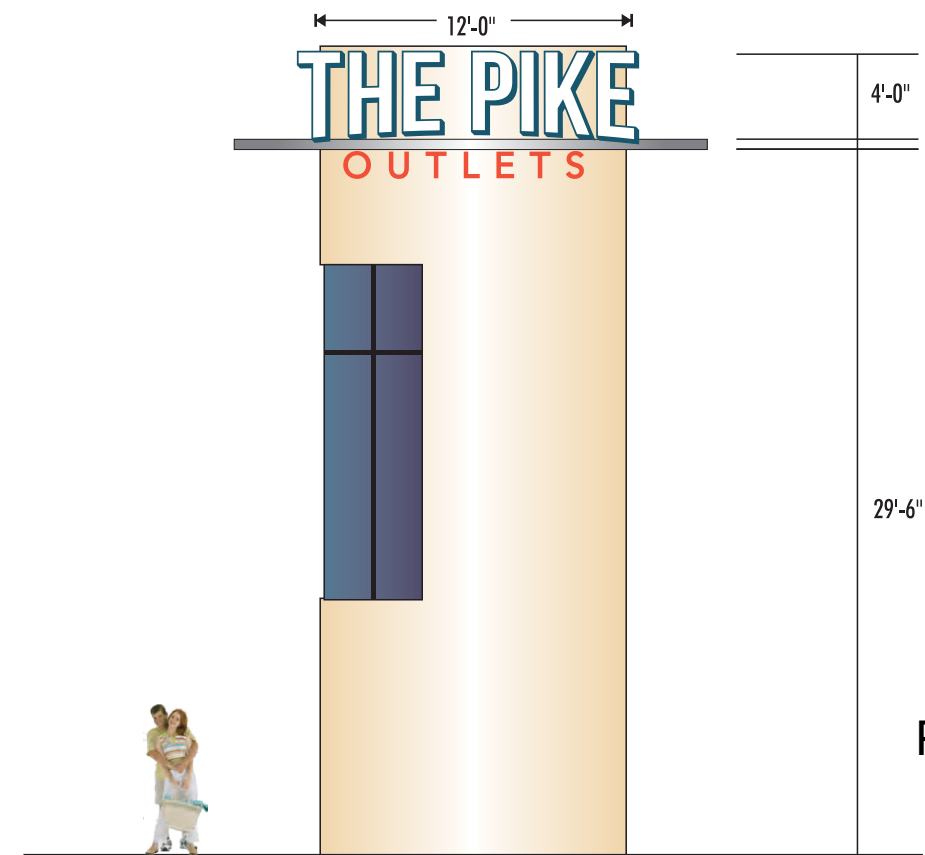
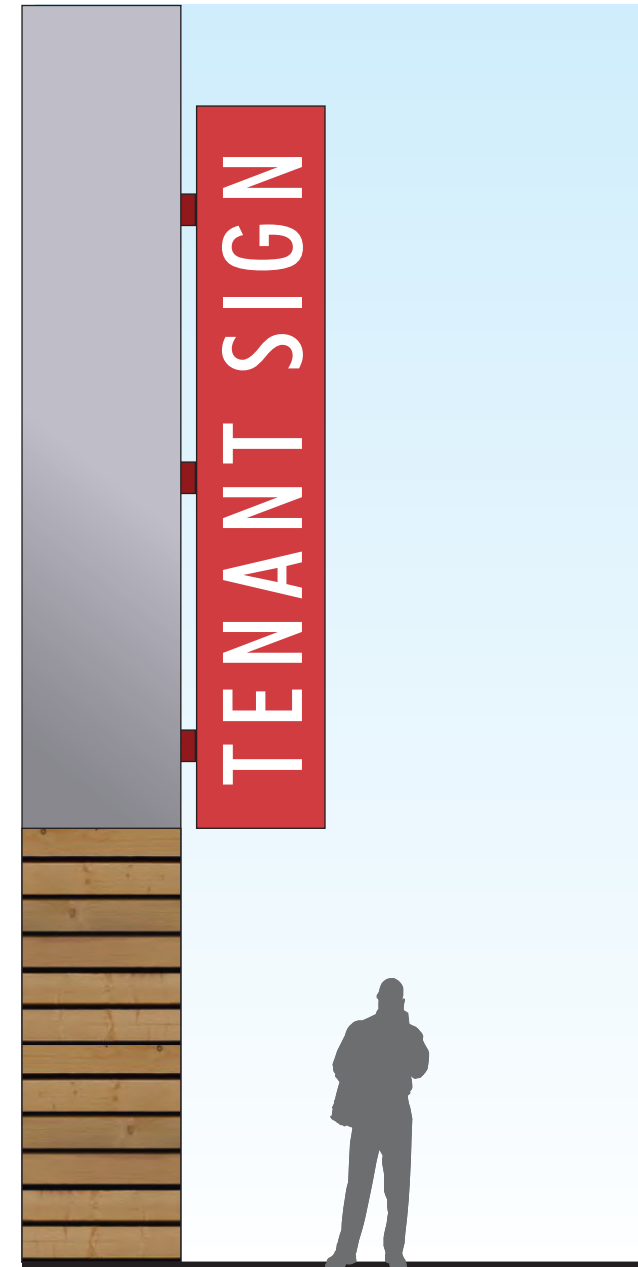
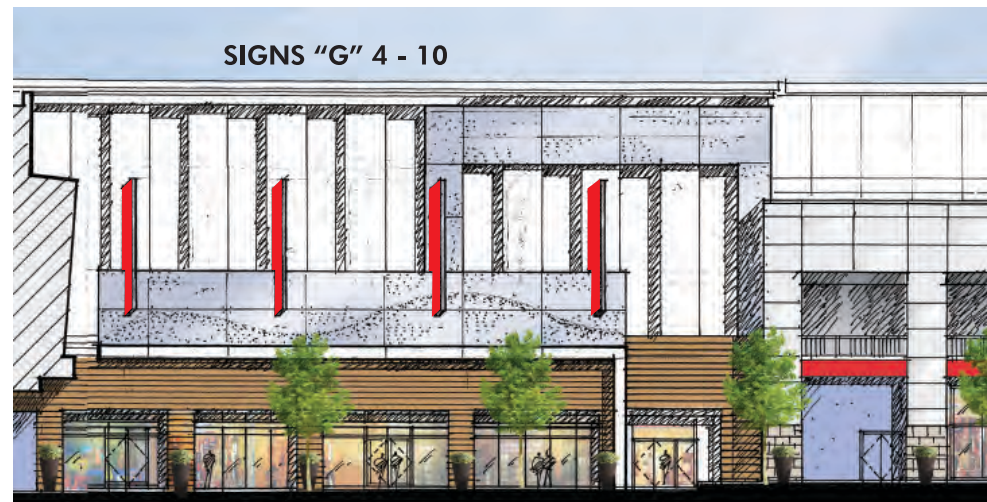
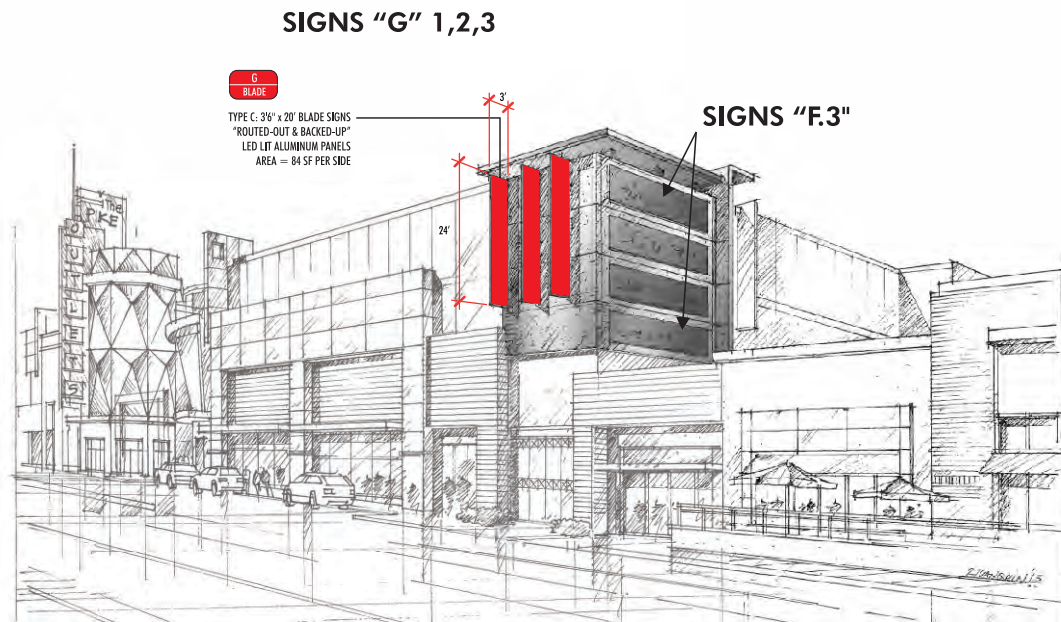
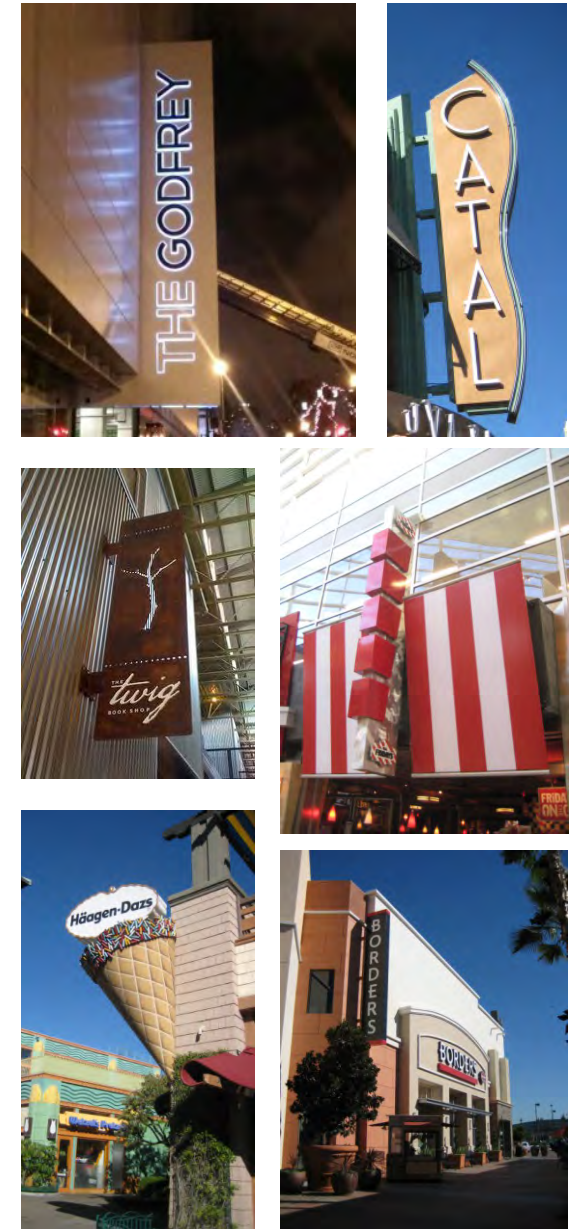

Exhibit 12  
Page 1 of 1





**G** SIGN TYPE - G: PROJECTING BLADE SIGN  
SCALE: 1/4" = 1'-0"



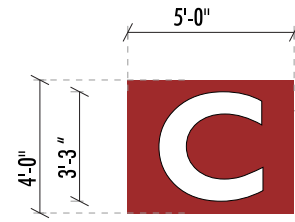

ADD (2) TOP ALUM. NESTED PAN PANELS PAINTED TO MATCH PMS 1807 C RED. SIZE TO MATCH EXISTING TO ACCOMMODATE LETTER 'C' AND INSTALL BACK TO BACK TO EXISTING STRUCTURE WITH SPACERS AND BRACING AS NEEDED.

(14) FLAT ALUM. OVERLAY PANELS PAINTED TO MATCH PMS 1807 C RED (T.B.D.) INSTALLED FLUSHED ON EXISTING PANELS.

PCL's - (2) SETS REQUIRED  
5" BLACK PRE-FINISHED ALUM RETURNS. BLACK TRIMCAPS WHITE ACRYLIC FACES INTERNALLY ILLUMINATED with WHITE LED POWER SUPPLIES INSIDE EXISTING STRUCTURE

**SURVEY REQUIRED** TO OBTAIN PANEL MEASUREMENTS AND CONFIRM ACCESS FOR INSTALL AND SERVICE. (DETERMINE POWER SUPPLY PLACEMENT.)



BEFORE



AFTER

TWO SETS (2) REQUIRED  
20 SQ. FT. PER INDIVIDUAL SIGN PANEL  
160 SQ. FT. TOTAL PER SIDE (COMBINED PANELS)





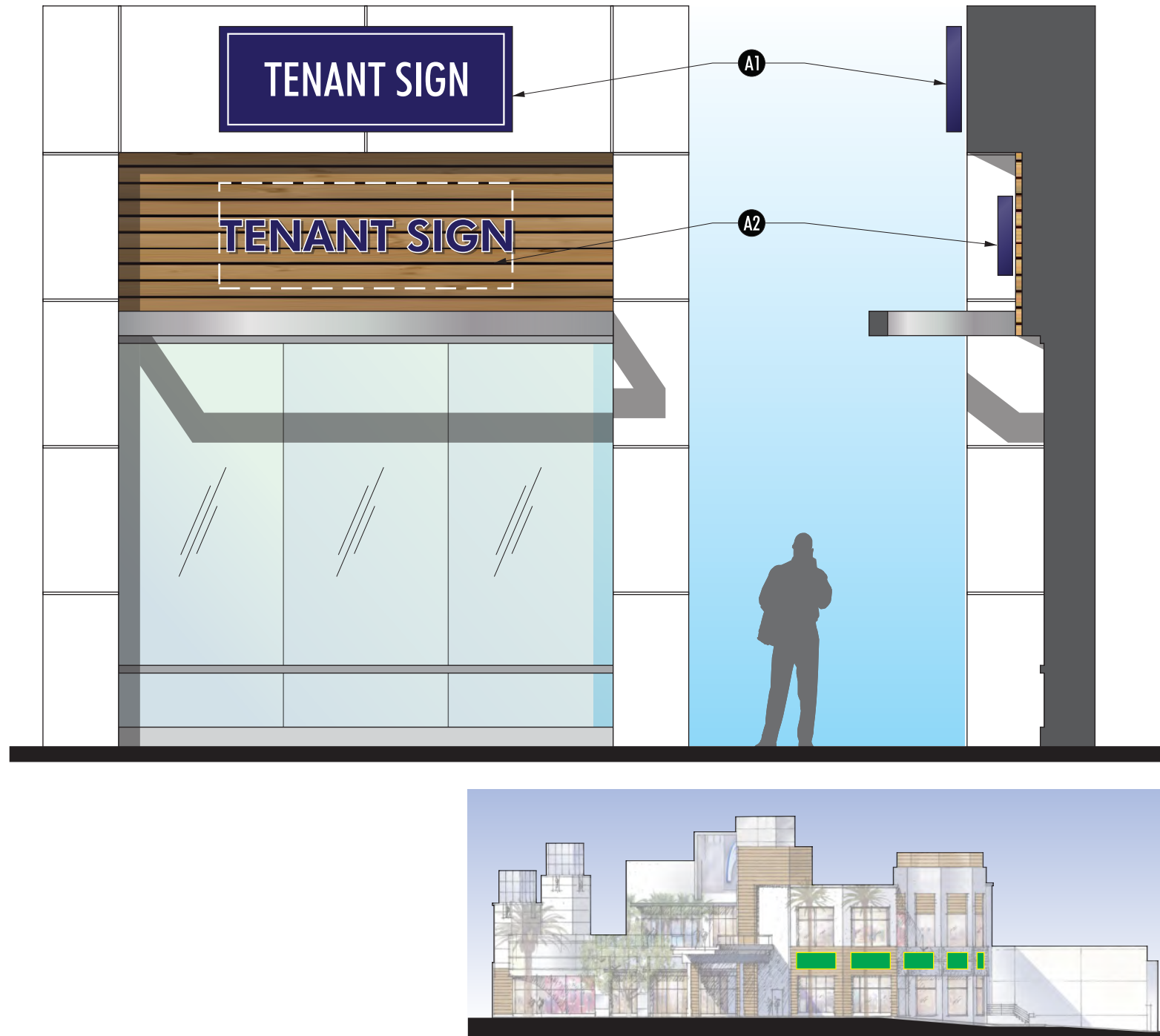

FRONT ELEVATION:

- A1 CHANNEL SIGN CABINET w/ INTERNAL-ILLUMINATION THRU ACRYLIC FACE
- A2 CHANEL LETTERS/LOGO w/ INTERNAL-ILLUMINATION THRU ACRYLIC FACE



**A** SIGN TYPE - A: WALL MOUNT CHANNEL SIGN D  
 SCALE: 1/4" = 1'-0" CHANNEL

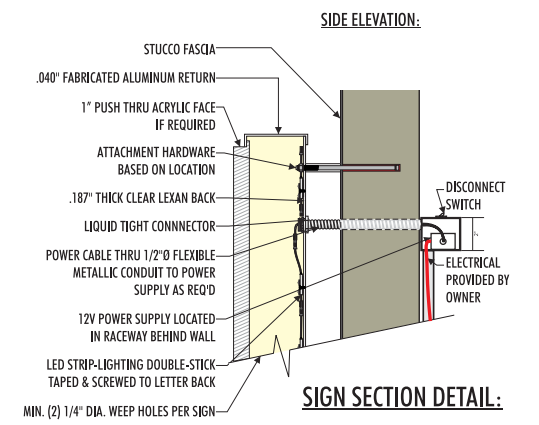



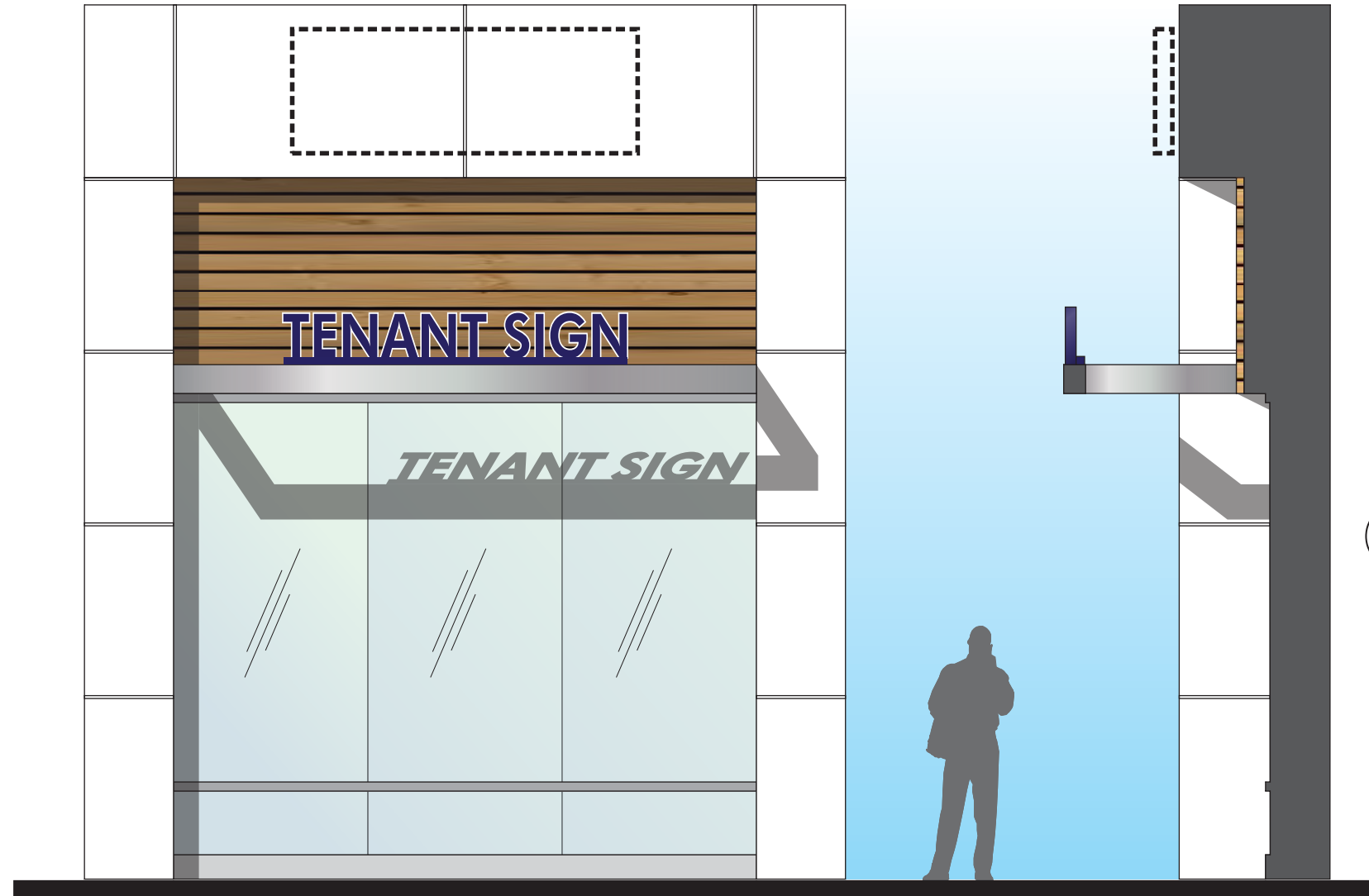

**B** SIGN TYPE - B: RACEWAY MOUNTED CHANNEL SIGN **E**  
RACEWAY  
SCALE: 1/4" = 1'-0"

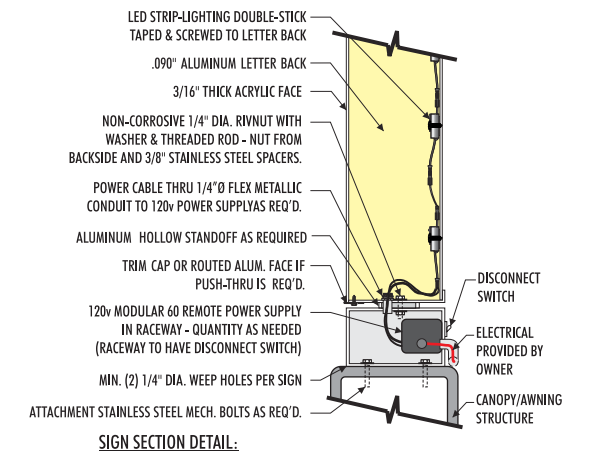

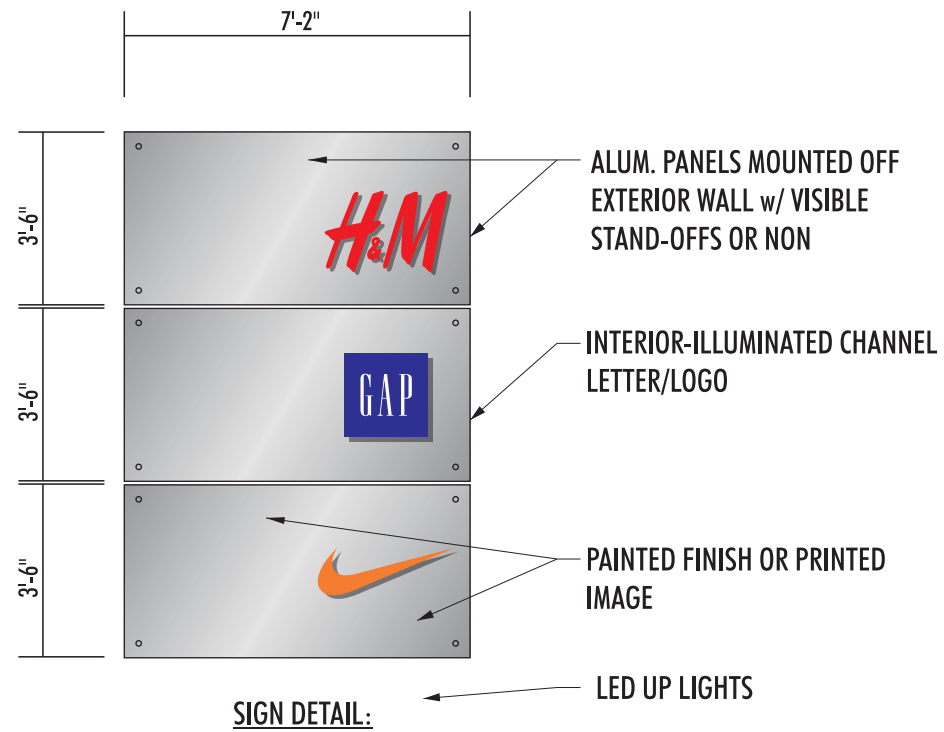

- A1 CHANNEL SIGN CABINET w/ INTERNAL-ILLUMINATION THRU ACRYLIC FACE
- A2 CHANNEL LETTERS/LOGO w/ INTERNAL-ILLUMINATION THRU ACRYLIC FACE

**F** SIGN TYPE - F: PANEL SIGNS  
SCALE: 1/4" = 1'-0"

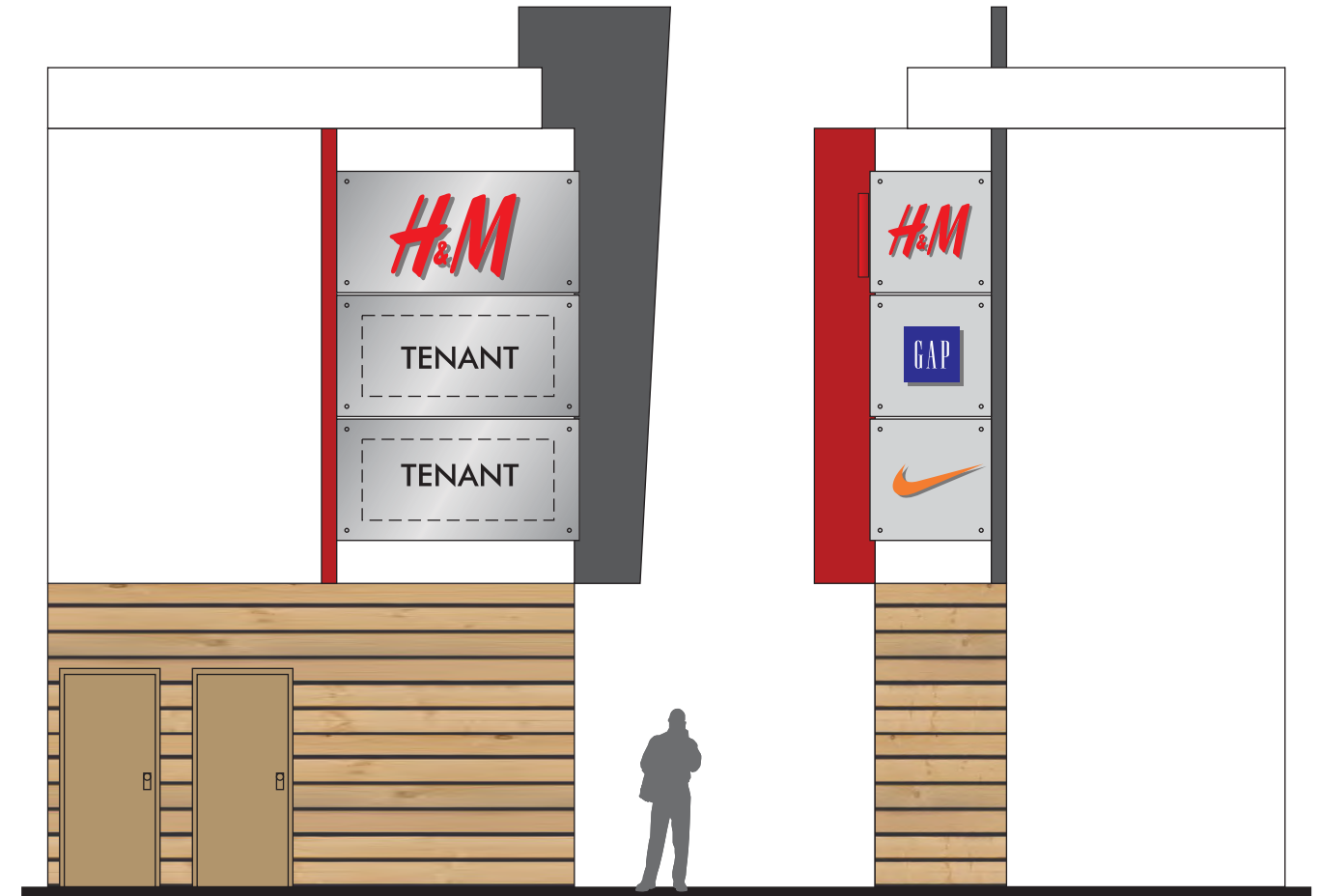

**F.1 & F.2**  
6' X 20' ALUMINUM TENANT PANELS FOR ILLUMINATED CHANNEL LETTERS

