

# Item Th 9c

STATE OF CALIFORNIA -- THE RESOURCES AGENCY

ARNOLD SCHWARZENEGGER, Governor

## CALIFORNIA COASTAL COMMISSION

SOUTH CENTRAL COAST AREA  
SOUTH CALIFORNIA ST., SUITE 200  
VENTURA, CA 93001  
(805) 585-1800

Filed: 7/27/04  
49th Day: 9/14/04  
180th Day: 1/23/0  
Staff: Carey  
Staff Report: 11/18/04  
Hearing Date: 12/8-10/04



## RECORD PACKET COPY

### STAFF REPORT: REGULAR CALENDAR

**APPLICATION NO.:** 4-03-065

**APPLICANT:** Las Virgenes Municipal Water District **AGENT:** Envicom Corporation

**PROJECT LOCATION:** Northeast corner of Mulholland Highway and Decker Road, Santa Monica Mountains, Los Angeles County

**PROJECT DESCRIPTION:** Extension of recycled water service to provide irrigation for an existing golf course (Malibu County Club), including the creation of a water tank parcel, construction of a 60-foot diameter, 400,000 gallon water tank, extension of pipe from the tank site along Mulholland Highway and along an existing disturbed roadway within the golf course, 15,073 cu. yds of grading (5,650 cu. yds. cut and 9,423 cu. yds. fill), and revegetation of disturbed areas.

**LOCAL APPROVALS RECEIVED:** N/A

**SUBSTANTIVE FILE DOCUMENTS:** Preliminary Geotechnical Data Report, dated September 18, 2001, Preliminary Geotechnical Study, Proposed Water Tank Site, dated November 14, 2001, and a Response to State Coastal Commission Item Number 15 Letter, dated August 27, 2003, all prepared by Fugro West, Inc.

#### SUMMARY OF STAFF RECOMMENDATION

Staff recommends **approval** of the proposed development with special conditions regarding geological recommendations, and revegetation of graded and disturbed areas. As conditioned, the proposed project will minimize impacts to life and property from hazards, and minimize impacts to water quality and ESHA, consistent with the policies of the Coastal Act.

**STAFF RECOMMENDATION:**

The staff recommends that the Commission adopt the following resolution:

**I. Approval with Conditions**

**I. STAFF RECOMMENDATION**

**MOTION:** *I move that the Commission approve Coastal Development Permit No 4-03-065 pursuant to the staff recommendation.*

**STAFF RECOMMENDATION OF APPROVAL:**

Staff recommends a YES vote. Passage of this motion will result in approval of the permit as conditioned and adoption of the following resolution and findings. The motion passes only by affirmative vote of a majority of the Commissioners present.

**RESOLUTION TO APPROVE THE PERMITS:**

The Commission hereby approves the Coastal Development Permit for the proposed development and adopts the findings set forth below on grounds that the development as conditioned will be in conformity with the policies of Chapter 3 of the Coastal Act and will not prejudice the ability of the local government having jurisdiction over the area to prepare a Local Coastal Program conforming to the provisions of Chapter 3. Approval of the permits complies with the California Environmental Quality Act because either 1) feasible mitigation measures and/or alternatives have been incorporated to substantially lessen any significant adverse effects of the development on the environment, or 2) there are no further feasible mitigation measures or alternatives that would substantially lessen any significant adverse impacts of the development on the environment.

**II. Standard Conditions**

**1. Notice of Receipt and Acknowledgment.** The permit is not valid and development shall not commence until a copy of the permit, signed by the permittee or authorized agent, acknowledging receipt of the permit and acceptance of the terms and conditions, is returned to the Commission office.

**2. Expiration.** If development has not commenced, the permit will expire two years from the date on which the Commission voted on the application. Development shall be pursued in a diligent manner and completed in a reasonable period of time. Application for extension of the permit must be made prior to the expiration date.

**3. Interpretation.** Any questions of intent or interpretation of any condition will be resolved by the Executive Director or the Commission.

4. **Assignment.** The permit may be assigned to any qualified person, provided assignee files with the Commission an affidavit accepting all terms and conditions of the permit.

5. **Terms and Conditions Run with the Land.** These terms and conditions shall be perpetual, and it is the intention of the Commission and the permittee to bind all future owners and possessors of the subject property to the terms and conditions.

### **III. Special Conditions**

#### **1. Plans Conforming to Geotechnical Engineer's Recommendations**

All recommendations contained in the Preliminary Geotechnical Data Report, dated September 18, 2001, Preliminary Geotechnical Study, Proposed Water Tank Site, dated November 14, 2001, and a Response to State Coastal Commission Item Number 15 Letter, dated August 27, 2003, all prepared by Fugro West, Inc. shall be incorporated into all final design and construction, including recommendations concerning foundations, grading, and drainage, and must be reviewed and approved by the consultant prior to commencement of development. Prior to issuance of the coastal development permit, the applicant shall submit evidence to the Executive Director of the consultant's review and approval of all final design and construction plans.

The final plans approved by the consultant shall be in substantial conformance with the plans approved by the Commission relative to construction, grading, and drainage. Any substantial changes in the proposed development approved by the Commission that may be required by the consultant shall require amendment(s) to the permit(s) or new Coastal Development Permit(s).

#### **2. Revegetation/Landscaping and Erosion Control Plans**

***Prior to the issuance of the coastal development permit***, the applicant shall submit landscaping and erosion control plans, prepared by a licensed landscape architect or qualified resource specialist, for review and approval by the Executive Director. The plans shall incorporate the following criteria:

##### **A) Landscaping Plan**

- 1) All graded and disturbed areas on the subject sites, including the water tank area and the pipeline route, shall be planted and maintained for revegetation and erosion control purposes within thirty (30) days of completion of the proposed development. Planting should be of native plant species indigenous to the Santa Monica Mountains, compatible with the surrounding environment, using accepted planting procedures, and consistent with fire safety requirements. Such planting shall be adequate to provide ninety (90) percent coverage within two (2) years, and this requirement shall apply to all disturbed and graded soils: Invasive, non-indigenous plant species that tend to supplant native species shall not be used.

The plan shall specify the erosion control measures to be implemented and the materials necessary to accomplish short-term stabilization, as needed on the site.

- 2) Plantings shall be maintained in good growing condition throughout the life of the project and, whenever necessary, shall be replaced with new plant materials to ensure continued compliance with applicable landscape requirements;
- 3) The plan shall include a detailed plan and planting specifications for the compensatory area of purple needlegrass of approximately 1,000 sq. ft., as recommended in the biological report for the tank and pipeline sites, dated June 6, 2003, prepared by Envicom Corporation.
- 4) The Permittee shall undertake development in accordance with the final approved plan. Any proposed changes to the approved final plan shall be reported to the Executive Director. No changes to the approved final plan shall occur without a Coastal Commission - approved amendment(s) to the Coastal Development Permit(s), unless the Executive Director determines that no amendment is required.

**B) Interim Erosion Control Plan**

- 1) The plan shall delineate the areas to be disturbed by grading or construction activities and shall include any temporary access roads, staging areas, and stockpile areas. The natural areas on the sites shall be clearly delineated on the project site with fencing or survey flags.
- 2) The plan shall specify that grading shall take place only during the dry season (April 1 – October 31). This period may be extended for a limited period of time if the situation warrants such a limited extension, if approved by the Executive Director. The applicant shall install or construct temporary sediment basins (including debris basins, desilting basins, or silt traps), temporary drains and swales, sand bag barriers, silt fencing, and shall stabilize any stockpiled fill with geofabric covers or other appropriate cover, install geotextiles or mats on all cut or fill slopes, and close and stabilize open trenches as soon as possible. These erosion control measures shall be required on the project site prior to or concurrent with the initial grading operations and maintained throughout the development process to minimize erosion and sediment from runoff waters during construction. All sediment should be retained on-site, unless removed to an appropriate, approved dumping location either outside of the coastal zone or within the coastal zone to a site permitted to receive fill.
- 3) The plan shall also include temporary erosion control measures should grading or site preparation cease for a period of more than thirty (30) days, including but not limited to: stabilization of all stockpiled fill, access roads, disturbed soils, and cut and fill slopes with geotextiles and/or mats, sand bag barriers, silt fencing; temporary drains and swales and sediment basins. The plans shall also specify that all disturbed areas shall be seeded with native grass species and include the

technical specifications for seeding the disturbed areas. These temporary erosion control measures shall be monitored and maintained until grading or construction operations resume.

### **C. Monitoring**

Five (5) years from the date of completion of the proposed development, the applicant shall submit for the review and approval of the Executive Director a revegetation monitoring report, prepared by a licensed Landscape Architect or qualified Resource Specialist, that certifies the on-site revegetation is in conformance with the landscape plan approved pursuant to this special condition. The monitoring report shall include photographic documentation of plant species and plant coverage.

If the revegetation monitoring report indicates the revegetation is not in conformance with or has failed to meet the performance standards specified in the revegetation plan approved pursuant to this permit, the applicant, or successors in interest, shall submit a revised or supplemental revegetation plan for the review and approval of the Executive Director. The revised landscaping plan must be prepared by a licensed landscape architect or qualified resource specialist and shall specify measures to remediate those portions of the original plan that have failed or are not in conformance with the original approved plan.

## **IV. Findings and Declarations**

The Commission hereby finds and declares:

### **A. Project Description and Background**

The applicant proposes to extend an existing recycled water system to the Malibu Country Club, where recycled water provided by the Tapia Water Reclamation Facility will be used to irrigate an existing golf course that currently uses potable water for irrigation. The applicant has stated that this golf course is the largest potable water user within the Las Virgenes Municipal Water District. The applicant estimates that eighty percent of the golf course's water needs can be served by recycled water rather than potable water. It is anticipated that the proposed project will expand the beneficial use of recycled water, which will both minimize demand for potable water and allow the applicant to avoid reclaimed water discharges to Malibu Creek which are prohibited during dry months.

The overall project includes the extension of pipe along Westlake Boulevard from an existing line at Potrero Road (City of Thousand Oaks), outside of the Coastal Zone. This pipe extends to the project site just inside the Coastal Zone boundary at the corner of Westlake Boulevard and Mulholland Highway.

The portion of the overall project considered in the subject permit application includes the creation of a separate 1-acre water tank parcel, and the construction of a 60-foot

diameter, 400,000-gallon water tank on this site with 14,400 cu. yds of grading (5,300 cu. yds. cut and 9,100 cu. yds. fill). A pipeline will extend from the tank southeast along Mulholland Highway for a distance of 1,100 feet and will extend along an existing disturbed roadway within the golf course for a distance of 2,500 feet. Trenching to install the pipeline will include 350 cu. yds. cut and 323 cu. yds. fill. The recycled water pipeline will parallel an existing potable water pipe and will end at a new water meter adjacent to the existing water meter. Finally, the applicant proposes the revegetation of disturbed areas.

The Malibu Country Club golf course (owned by California Fuji International Inc.) is accessed from Encinal Canyon Road and the property extends north to Mulholland Highway (Exhibit 1). The golf course property comprises several separate parcels. The installation of the pipeline will cross four of the golf course parcels. The proposed project site for the water tank is located just north of Mulholland Highway on an existing parcel that is approximately 29.5 acres in size and is also owned by California Fuji International Inc. The proposed tank site parcel will be approximately 1-acre in size, will contain the proposed tank, access road, and slopes. The ownership of this parcel will be transferred in fee to the applicant by California Fuji International, Inc. according to a memorandum of understanding between the two. Exhibit 1 shows the location of the tank site and the pipeline extension. Exhibit 2 is the site plan of the tank site and Exhibit 3 is the site plan for the pipeline.

Staff has reviewed aerial photographs of the area. A January 1977 aerial photo of the area indicates that the lower portion of the golf course had already been completed prior to the effective date of the Coastal Act. Additionally, the upper portion of the golf course had already been graded by that date, but it does not appear that it had been completed. The access road along which the applicant proposes to install pipeline from Mulholland Hwy. to the golf course was existing on the site in 1977. The proposed water tank site was already disturbed in 1977, apparently as part of firebreak that runs east and west across many properties in the area. Later aerial photographs from 1986 and 2001 indicate that this firebreak has been maintained. The roadway is still apparent in the later photos, although it is less distinct.

The Commission has considered several permit applications for development on the subject project sites. Permit 5-85-288 (California Fuji International) was approved for the construction of a clubhouse, showers, parking lot, maintenance and cart storage sheds, tennis court, swimming pool, expansion of parking lot and road, 121 parking spaces, and 77,000 cu. yds. of grading at the existing golf course. This permit was subject to special conditions requiring preservation of riparian area, open space easement, and reservation of membership for public recreation.

Permit 5-85-612 (California Fuji International) was approved for the grading of an access road and installation of a 730,000-gallon water tank. The permit was subject to special conditions requiring dedication of a trail easement and landscaping. The Commission later denied a permit extension for this project, finding that changed circumstances existed in that the proposed size of the tank was not designed only to

provide for existing uses, but to provide for later residential development that was pending approval with the County.

Permit 5-90-035 (California Fuji International) was approved for the addition of a 4,700 sq. ft. locker room over an existing golf cart storage structure. Permit 5-90-188 (California Fuji International) was approved for the construction of 2 fences for a golf practice area. Permit 4-97-125 (California Fuji International) was approved for construction of a 490 sq. ft. snack bar area.

## **B. Geology & Hazards**

The proposed development is located in the Malibu/Santa Monica Mountains area, an area that is generally considered to be subject to an unusually high amount of natural hazards. Geologic hazards common to the Santa Monica Mountains area include landslides, erosion, and flooding. In addition, fire is an inherent threat to the indigenous chaparral community of the coastal mountains. Wildfires often denude hillsides in the Santa Monica Mountains of all existing vegetation, thereby contributing to an increased potential for erosion and landslides on property. In this case, the proposed development includes installation of a water tank and recycled water pipeline which will not be at risk from fire.

Section 30253 of the Coastal Act states, in pertinent part, that new development shall:

- (1) Minimize risks to life and property in areas of high geologic, flood, and fire hazard.***
- (2) Assure stability and structural integrity, and neither create nor contribute significantly to erosion, instability, or destruction of the site or surrounding area or in any way require the construction of protective devices that would substantially alter natural landforms along bluffs and cliffs.***

The applicant submitted a Preliminary Geotechnical Data Report, dated September 18, 2001, Preliminary Geotechnical Study, Proposed Water Tank Site, dated November 14, 2001, and a Response to State Coastal Commission Item Number 15 Letter, dated August 27, 2003, all prepared by Fugro West, Inc. for the proposed project. These reports address the geologic materials found along the proposed pipeline routes as well as on the water tank site. The reports state that there does not appear to be any significant geohazards such as active faulting or large-scale landslides that would impact the proposed pipeline route or the water tank site. Several recommendations are provided regarding the trenching for the pipeline and excavation, foundations and drainage provisions for the tank. The geotechnical report concludes that:

In our opinion, the geologic/geotechnical conditions at the proposed site are geotechnically suitable and stable to construct the water tank, as currently proposed.

The Geotechnical Report contains several recommendations to be incorporated into project excavation, grading, construction, drainage, and foundations to ensure the stability and geologic safety of the proposed project site and adjacent property. To ensure that the recommendations of the consultant have been incorporated into all proposed development the Commission, as specified in **Special Condition 1**, requires the applicant to submit project plans certified by the consulting geologist and geotechnical engineer as conforming to all structural and site stability recommendations for the proposed project. Final plans approved by the consultant shall be in substantial conformance with the plans approved by the Commission. Any substantial changes to the proposed developments, as approved by the Commission, which may be recommended by the consultant shall require an amendment to the permit or a new coastal development permit.

The Commission finds that minimizing and controlling erosion from the construction site during construction will add to the geologic stability of the project site. To ensure that adequate erosion control is included in the proposed developments the Commission requires the applicant to submit interim erosion control plans, as specified in **Special Condition 2**. The Commission also finds that revegetation of graded and disturbed areas on the subject site will serve to stabilize disturbed soils, reduce erosion and thus enhance and maintain the geologic stability of the site. Therefore, **Special Condition 2** requires the applicant to submit revegetation/landscaping plans. Special Condition 2 also requires the applicant to utilize and maintain native and noninvasive plant species compatible with the surrounding area for landscaping the project sites. Invasive and non-native plant species are generally characterized as having a shallow root structure in comparison with their high surface/foilage weight. The Commission notes that non-native and invasive plant species with high surface/foilage weight and shallow root structures do not serve to stabilize slopes and that such vegetation results in potential adverse effects to the stability of the project site. Native species, alternatively, tend to have a deeper root structure than non-native and invasive species, and once established aid in preventing erosion.

The Commission finds that the proposed project, as conditioned, will minimize potential geologic hazards of the project site and adjacent properties, consistent with Section 30235 of the Coastal Act.

### **C. Environmentally Sensitive Habitat**

Section 30230 of the Coastal Act states that:

***Marine resources shall be maintained, enhanced, and where feasible, restored. Special protection shall be given to areas and species of special biological or economic significance. Uses of the marine environment shall be carried out in a manner that will sustain the biological productivity of coastal waters and that will maintain healthy populations of all species of marine organisms adequate for long-term commercial, recreational, scientific, and educational purposes.***



Section 30231 states:

***The biological productivity and the quality of coastal waters, streams, wetlands, estuaries, and lakes appropriate to maintain optimum populations of marine organisms and for the protection of human health shall be maintained and, where feasible, restored through, among other means, minimizing adverse effects of waste water discharges and entrainment, controlling runoff, preventing depletion of ground water supplies and substantial interference with surface water flow, encouraging waste water reclamation, maintaining natural vegetation buffer areas that protect riparian habitats, and minimizing alteration of natural streams.***

Section 30240 states:

***(a) Environmentally sensitive habitat areas shall be protected against any significant disruption of habitat values, and only uses dependent on such resources shall be allowed within such areas.***

***(b) Development in areas adjacent to environmentally sensitive habitat areas and parks and recreation areas shall be sited and designed to prevent impacts which would significantly degrade such areas, and shall be compatible with the continuance of such habitat areas.***

Section 30107.5 of the Coastal Act, defines an environmentally sensitive area as:

***"Environmentally sensitive area" means any area in which plant or animal life or their habitats are either rare or especially valuable because of their special nature or role in an ecosystem and which could be easily disturbed or degraded by human activities and developments.***

Section 30231 of the Coastal Act requires that the biological productivity and the quality of coastal waters and streams be maintained and, where feasible, restored through, among other means, controlling runoff, preventing depletion of ground water supplies and substantial interference with surface water flows, maintaining natural buffer areas that protect riparian habitats, and minimizing alteration of natural streams. In addition, Sections 30107.5 and 30240 of the Coastal Act state that environmentally sensitive habitat areas must be protected against disruption of habitat values. Therefore, when considering any area, such as the Santa Monica Mountains, with regard to an ESHA determination one must focus on three main questions:

- 1) Is a habitat or species rare?
- 2) Is the habitat or species especially valuable because of its special nature or role in the ecosystem?
- 3) Is the habitat or species easily disturbed or degraded by human activities and developments?

The Coastal Commission has found that the Mediterranean Ecosystem in the Santa Monica Mountains is itself rare, and valuable because of its relatively pristine character, physical complexity, and resultant biological diversity. Therefore, habitat areas that provide important roles in that ecosystem are especially valuable and meet the second criterion for the ESHA designation. In the Santa Monica Mountains, coastal sage scrub and chaparral have many important roles in the ecosystem, including the provision of critical linkages between riparian corridors, the provision of essential habitat for species that require several habitat types during the course of their life histories, the provision of essential habitat for local endemics, the support of rare species, and the reduction of erosion, thereby protecting the water quality of coastal streams. For these and other reasons discussed in Exhibit 5, which is incorporated herein, the Commission finds that large contiguous, relatively pristine stands of coastal sage scrub and chaparral in the Santa Monica Mountains meet the definition of ESHA. This is consistent with the Commission's past findings on the Malibu LCP<sup>1</sup>.

For any specific property within the Santa Monica Mountains, it is necessary to meet three tests in order to assign the ESHA designation. First, is the habitat properly identified, for example as coastal sage scrub or chaparral? Second, is the habitat undeveloped and otherwise relatively pristine? Third, is the habitat part of a large, contiguous block of relatively pristine native vegetation?

The subject site for the construction of the water tank is located northeast of the corner of Westlake Boulevard and Mulholland Highway. The pipeline extends southeast along Mulholland Highway and south into the golf course. The 29.5-acre project site where the water tank will be constructed is well vegetated with the exception of a firebreak that runs along the ridge and down the slope on the western side. This area is almost completely denuded of vegetation. The golf course property where the pipeline is proposed is also well vegetated outside of the developed fairways and greens. There is an existing roadway that extends south and southwest from Mulholland Highway across this area of the site. A January 1977 aerial photo of the area indicates that the proposed water tank site was already disturbed in 1977, as part of a firebreak that runs east and west across many properties in the area (in fact, the firebreak apparently existed prior to 1950 as it is shown on the Department of County Forester and Fire Warden, Divisional Map No. 1, Battalion 5, 1950 edition). Additionally, the access road along which the applicant proposes to install pipeline was existing on the site prior to 1977. Later aerial photographs from 1986 and 2001 indicate that the firebreak has been maintained. The roadway is still apparent in the later photos, although it is less distinct.

The applicant submitted a biological report for the tank and pipeline sites, dated June 6, 2003, prepared by Envicom Corporation. With regard to the tank site, the report states that:

Recently, the vegetation has been virtually removed, perhaps as part of a major fuelbreak construction... From the debris, it is evident that the dominant vegetation was

---

<sup>1</sup> Revised Findings for the City of Malibu Local Coastal Program (as adopted on September 13, 2002) adopted on February 6, 2003.

chaparral and scrub. The remnant living and regenerating plants include laurel sumac (*Malosma laurina*), coyote brush (*Baccharis pilularis*), sawtooth goldenbush (*Hazardia squarrosa grindelioides*), California-aster (*Corethrogyne filaginifolia*), California everlasting (*Gnaphalium californicum*), black sage (*Salvia mellifera*), purple sage (*Salvia leucophylla*), California buckwheat (*Eriogonum fasciculatum*), big-pod ceanothus (*Ceanothus megacarpus*), chamise (*Adenostoma fasciculatum*), and Whipple's yucca (*Yucca whipplei*). A host of weedy alien and native annuals, biennials and perennials are also present.

With regard to the pipeline route, the report notes that the pipeline will follow the existing roadway and that: "...the alignment occupies disturbed habitat areas of former chaparral, which is in various stages of recovery along its length". The report also states that:

During the course of the survey, a small pocket of purple needlegrass (*Nassella pulchra*), was observed at the first white post down from the abandoned house, occupying about a 50-foot long roadway segment. Although this is not a sensitive species, the habitats wherein this species dominates (Valley Needlegrass Grassland) are considered very threatened, and the Coastal Commission strongly objected to their loss in a recent instance involving the expansion of Pepperdine's Malibu Campus. For this reason, mitigation of this impact is recommended in the form of restoration of a compensatory area on the completed pipeline, or adjacent thereto. Such a restoration should endeavor to achieve a 2:1 replacement of habitat, and could be implemented through direct salvage of the perennial plants, also in conjunction with a program of seed collection and propagation or dispersal. The area impacted is estimated at approximately 500 square feet. With this measure, the impact to Valley Needlegrass Grassland would be insignificant.

As previously noted, the majority of the tank project site, with the exception of the firebreak, is well vegetated with plant species identified by the project biologist to be chaparral with coastal sage scrub plant species. Additionally, there is a large contiguous area of undisturbed habitat northeast and south of the tank site. Further, the pipeline area south of Mulholland Highway is, with the exception of the existing disturbed roadway, also well vegetated with the same vegetation types. As shown in the aerial photograph of the surrounding area (Exhibit 6), there is scattered existing development along Mulholland Highway and Westlake Boulevard in the area. To the east of the site, there is a large area that is not developed that retains the native habitat.

Therefore, due to the important ecosystem roles of coastal sage scrub and chaparral in the Santa Monica Mountains (detailed in Exhibit 7), and the fact that the subject site is relatively undisturbed and part of a large, unfragmented block of habitat, the Commission finds that the chaparral and coastal sage scrub on and surrounding the project site meets the definition of ESHA under the Coastal Act (excluding the fire break area on the water tank site and the disturbed roadway area on the golf course sites that were created prior to the effective date of the Coastal Act and maintained to the present).

As explained above, the project site Act (excluding the fire break area on the water tank site and the disturbed roadway area on the golf course sites that were created prior to the effective date of the Coastal Act and maintained to the present) and the surrounding area constitutes an environmentally sensitive habitat area (ESHA) pursuant to Section 30107.5. Section 30240 requires that "environmentally sensitive habitat areas shall be protected against any significant disruption of habitat values, and only uses dependent on those resources shall be allowed within those areas." Section 30240 restricts development within ESHA to only those uses that are dependent on the resource. The applicant proposes to construct a water tank and water pipeline. The water tank is proposed to be located on a highly disturbed area that was denuded of vegetation for a fire break as early as 1950 and has been maintained in this condition over time both prior to the Coastal Act and continuing to the present. This fire break area of the site does not support plants or animal life that constitute ESHA. Further, the construction of a water tank in this location will not require the removal of chaparral or coastal sage ESHA as a result of fuel modification for fire protection purposes, because the water tank is not a flammable structure. Similarly, the water pipeline will be located within the developed area of Mulholland Highway for a distance of 1,100 ft. and then within an existing disturbed roadway within the golf course property for a distance of 2,500 ft. This roadway existed prior to the Coastal Act. While there has been some regrowth of vegetation in the area of this roadway, it remains disturbed and not constituting ESHA. As such, the siting and design of the proposed water tank and pipeline will avoid the removal or modification of ESHA, thereby minimizing impacts.

The Commission has determined that in conjunction with siting new development to minimize impacts to ESHA, additional actions can be taken to minimize adverse impacts to ESHA. Assuring that all areas that are graded or disturbed by the project are properly revegetated minimizes impacts to water quality and streams from excessive erosion and sedimentation. Revegetation also prevents or minimizes the colonization of bare or disturbed soils with invasive, weedy species that can later spread to adjacent or nearby ESHA. Further, the Commission finds that the use of non-native and/or invasive plant species for revegetation or landscaping results in both direct and indirect adverse effects to native plants species indigenous to the Malibu/Santa Monica Mountains area. Adverse effects from such revegetation or landscaping result from the direct occupation or displacement of native plant communities by new development and associated non-native landscaping. Indirect adverse effects include offsite migration and colonization of native plant habitat by non-native/invasive plant species (which tend to outcompete native species) adjacent to new development. The Commission notes that the use of exotic plant species for revegetation or landscaping has already resulted in significant adverse effects to native plant communities in the Malibu/Santa Monica Mountains area. Therefore, in order to minimize adverse effects to ESHA, **Special Condition 2** requires that all disturbed or graded areas on the project site must be revegetated with plants that consist primarily of native plant species and that invasive plant species shall not be used. This condition requires the preparation and implementation of a revegetation plan that includes details regarding a replanting plan for the compensatory area of purple needlegrass, as recommended by the project biologist.

For the reasons set forth above, the Commission finds that the proposed project, as conditioned, is consistent with Sections 30230, 30231, and 30240 of the Coastal Act.

### C. Visual Resources

Section 30251 of the Coastal Act states:

***The scenic and visual qualities of coastal areas shall be considered and protected as a resource of public importance. Permitted development shall be sited and designed to protect views to and along the ocean and scenic coastal areas, to minimize the alteration of natural land forms, to be visually compatible with the character of surrounding areas, and, where feasible, to restore and enhance visual quality in visually degraded areas. New development in highly scenic areas such as those designated in the California Coastline reservation and Recreation Plan prepared by the Department of Parks and Recreation and by local government shall be subordinate to the character of its setting.***

Section 30251 of the Coastal Act requires scenic and visual qualities to be considered and preserved. Additionally, although the previously certified Malibu/Santa Monica Mountains Land Use Plan (LUP) is not the standard of review for development in Los Angeles County, the LUP provides policy guidance regarding visual resource issues specific to this particular case. The Malibu/Santa Monica Mountains LUP states in Policy P132 that:

***Maintain the character and value of Mulholland Scenic Corridor, as a scenic and recreational resource connecting public parklands within the Santa Monica Mountains.***

In addition, Policy 125 states that "new development shall be sited and designed to protect views from LCP designated scenic highways to and along the shoreline and to scenic areas." Policy 129 indicates "structures should be designed and located so as to create an attractive appearance and harmonious relationship with the surrounding environment."

The applicant proposes the construction of a 60-foot diameter, 400,000-gallon water tank on a disturbed slope, a recycled water pipeline leading from the tank to an existing golf course with 15,073 cu. yds of grading (5,650 cu. yds. cut and 9,423 cu. yds. fill). Of the total grading proposed, the installation of the pipeline requires 350 cu. yds. cut and 323 cu. yds. fill. The pipeline construction will have no significant impacts on visual resources, with the possible exception of views of the excavated area during construction. Such an impact will be of short duration and will be minimized by revegetation of the excavation area after construction.

However, the proposed water tank and the grading for its installation does have the potential to impact visual resources in the area. Water tanks are large structures most often constructed of metal that can have an appearance that is out of character with the surrounding natural environment. They can be seen from quite a distance, particularly if

they are placed in a prominent location or on a ridgeline. The subject site is located to the northeast and upslope of the intersection of Mulholland Highway and Westlake Boulevard in the Santa Monica Mountains. Mulholland Highway is a designated scenic corridor, and special emphasis has been placed by the LUP policies, and by Commission action, on protecting views within this corridor.

In this case, the proposed water tank site is in a prominent location on a slope above Mulholland Highway. The applicant's consultants prepared an analysis of the potential visibility of this development from the surrounding area. This analysis, dated May 29, 2003 (Envicom Corporation) states that

The proposed water tank site has a prominent intersection corner location, having frontages of approximately 215' on Mulholland Highway and 245' on Westlake Boulevard. With such a foreground location at a prominent intersection between important mountain roads, it would seem that the site could be easily seen and possibly be highly conspicuous in wide-ranging public views. However, local terrain variability in the immediate project vicinity and the orientations of the curving mountain roads substantially limits public visibility of the site from all but a few locations. The curving nature of the roads with their frequent steep hillside road-cuts limits site visibility from along each of three directions of approach to the site on Mulholland Highway and Westlake Boulevard.

Additionally, staff has confirmed that the proposed tank site will not be visible from public parklands or trails in the area.

Further, the applicant has sited the proposed water tank on a fairly steep slope that has been denuded of native vegetation as part of a firebreak. The applicant's representative has estimated that the top of the water tank will be at an approximate elevation of 1,866 feet while the crest of the ridge above is approximately 2,080 feet, or over 200 feet higher. As such, the tank will be located well below the ridge of the slope that continues above the tank. Exhibit 4 is a cross section that shows the relationship of the tank to the slope and ridge. Additionally, Exhibits 5 and 6 provide lines of sight for the proposed tank. The applicant proposes to cut into the slope such that a portion of the tank will be buried. Additionally, a fill slope will be constructed downslope of the tank. As proposed, the tank will be buried. The service road to provide access to the tank loops around the fill slope.

The project includes a large amount of grading (5,300 cu. yds. cut and 9,100 cu. yds. fill) for the water tank construction. Grading and landform alteration can result in adverse visual impacts, particularly in prominent locations, and where visible from parks, trails, scenic highways, or other public areas. In this case, the grading is proposed for the purpose of cutting the water tank into the slope and creating a fill slope that will further conceal the tank from view. The fill slope will blend into the natural slope. Therefore, although the proposed grading is a large amount of cut and fill, it will not result in significant landform alteration. The bare, graded slopes will be highly visible, but such an impact will be of short duration and will be minimized by revegetation of the area after the completion of construction.

Visual impacts associated with proposed grading, and the structure itself, can be further reduced by the use of appropriate and adequate landscaping. Therefore, **Special Condition 2** requires the applicant to prepare a revegetation plan relying on native, noninvasive plant species to ensure that the vegetation on site remains visually compatible with the native flora of surrounding areas. Implementation of Special Condition 2 will soften the visual impact of the development. To ensure that the final approved revegetation plans are successfully implemented, Special Condition 2 also requires the applicant to revegetate all disturbed areas in a timely manner and includes a monitoring component to ensure the successful establishment of all newly planted and landscaped areas over time.

The proposed project, as conditioned, will not result in a significant adverse impact to scenic public views or character of the surrounding area. Therefore the Commission finds that, as conditioned, the proposed development is consistent with section 30251 of the Coastal Act.

**C. New Development/Land Use Densities and Cumulative Impacts**

Section 30250 (a) of the Coastal Act provides that new development be located within or near existing developed areas able to accommodate it, with adequate public services, where it will not have significant adverse effects, either individually or cumulatively, on coastal resources:

***New residential, commercial, or industrial development, except as otherwise provided in this division, shall be located within, contiguous with, or in close proximity to, existing developed areas able to accommodate it or, where such areas are not able to accommodate it, in other areas with adequate public services and where it will not have significant adverse effects, either individually or cumulatively, on coastal resources. In addition, land divisions, other than leases for agricultural uses, outside existing developed areas shall be permitted only where 50 percent of the usable parcels in the area have been developed and the created parcels would be no smaller than the average size of surrounding parcels.***

Section 30105.5 of the Coastal Act defines the term "cumulatively", as it is applied in Section 30250(a) to mean that:

**... the incremental effects of an individual project shall be reviewed in conjunction with the effects of past projects, the effects of other current projects, and the effects of probable future projects.**

In past permit actions, the Commission has found that for Malibu and the Santa Monica Mountains, the coastal terrace area represents the existing developed area. The Commission has repeatedly emphasized, in past permit decisions, the need to address the cumulative impacts of new development in the Malibu/Santa Monica Mountains coastal zone. The Commission has reviewed land division applications to ensure that newly created or reconfigured parcels are of sufficient size, have access to roads and other utilities, are geologically stable and contain an appropriate potential

building pad area where future structures can be developed consistent with the resource protection policies of the Coastal Act. In particular, the Commission has ensured that future development on new or reconfigured lots can minimize landform alteration and other visual impacts, and impacts to environmentally sensitive habitat areas. Finally, the Commission has required that all new or reconfigured lots have adequate public services, including road, bridge, and driveway access that meets the requirements of the Fire Department.

In this case, the propose project includes the creation of a separate 1-acre parcel where the water tank would be constructed and maintained. The parent parcel is approximately 29.5-acres in size. Approximately 2/3 of the parcel is within the Coastal Zone. Portions of the site are designated for the following land use designations by the Malibu/Santa Monica Mountains Land Use Plan (LUP): Mountain Land II (1 dwelling per 20 acres); Rural Land I (1 dwelling per 10 acres) and Rural Land III (1 dwelling per 2 acres). The Commission has typically used the land use densities provided by the LUP as guidance in land division applications.

The proposed land division to create the 1-acre water tank site that will be owned by the Las Virgenes Municipal Water District does not increase the potential residential density of development on the site. It will not create any additional parcels that will be used for residential use. Rather, one separate parcel will be created for a public utility and will hold the water tank. The second parcel will be approximately 28.5 acres in size. As described above, the water tank construction has been sited and designed to minimize grading, landform alteration, and site disturbance. The development has been sited such that the water tank and grading will be located in an area of the site where vegetation has been removed consistently since at least the 1950s for a fire break. There are similarly disturbed habitat areas on the 28.5-acre site where future residential development could be sited in order to minimize any impacts to ESHA. Therefore, the proposed lot configuration and the development siting minimizes impacts to ESHA located on the site and the surrounding area. Finally, as discussed above, as conditioned, the proposed building sites on the two proposed parcels can be developed consistent with the Chapter Three policies of the Coastal Act. Therefore, for the reasons set forth above, the Commission finds, that the proposed project, as conditioned, will not result in any significant individual or cumulative adverse impacts on coastal resources and are consistent with Section 30250 of the Coastal Act.

#### **E. Local Coastal Program**

Section 30604 of the Coastal Act states:

*a) Prior to certification of the local coastal program, a coastal development permit shall be issued if the issuing agency, or the commission on appeal, finds that the proposed development is in conformity with the provisions of Chapter 3 (commencing with Section 30200) of this division and that the permitted development will not prejudice the ability of the local government to prepare a local program that is in conformity with the provisions of Chapter 3 (commencing with Section 30200).*



Section 30604(a) of the Coastal Act provides that the Commission shall issue a Coastal Development Permit only if the project will not prejudice the ability of the local government having jurisdiction to prepare a Local Coastal Program which conforms with Chapter 3 policies of the Coastal Act. The preceding sections provide findings that the proposed project will be in conformity with the provisions of Chapter 3 if certain conditions are incorporated into the project and are accepted by the applicant. As conditioned, the proposed development will not create adverse impacts and is found to be consistent with the applicable policies contained in Chapter 3. Therefore, the Commission finds that approval of the proposed development, as conditioned, will not prejudice the County of Los Angeles' ability to prepare a Local Coastal Program for this area which is also consistent with the policies of Chapter 3 of the Coastal Act, as required by Section 30604(a).

**F. CEQA**

Section 13096(a) of the Commission's administrative regulations requires Commission approval of a Coastal Development Permit application to be supported by a finding showing the application, as conditioned by any conditions of approval, to be consistent with any applicable requirements of the California Environmental Quality Act (CEQA). Section 21080.5(d)(2)(A) of CEQA prohibits a proposed development from being approved if there are feasible alternatives or feasible mitigation measures available which would substantially lessen any significant adverse effect that the activity may have on the environment.

The Commission finds that the proposed project, as conditioned, will not have significant adverse effects on the environment within the meaning of the California Environmental Quality Act of 1970. Therefore, the proposed project, as conditioned, has been adequately mitigated and is determined to be consistent with CEQA and the policies of the Coastal Act.

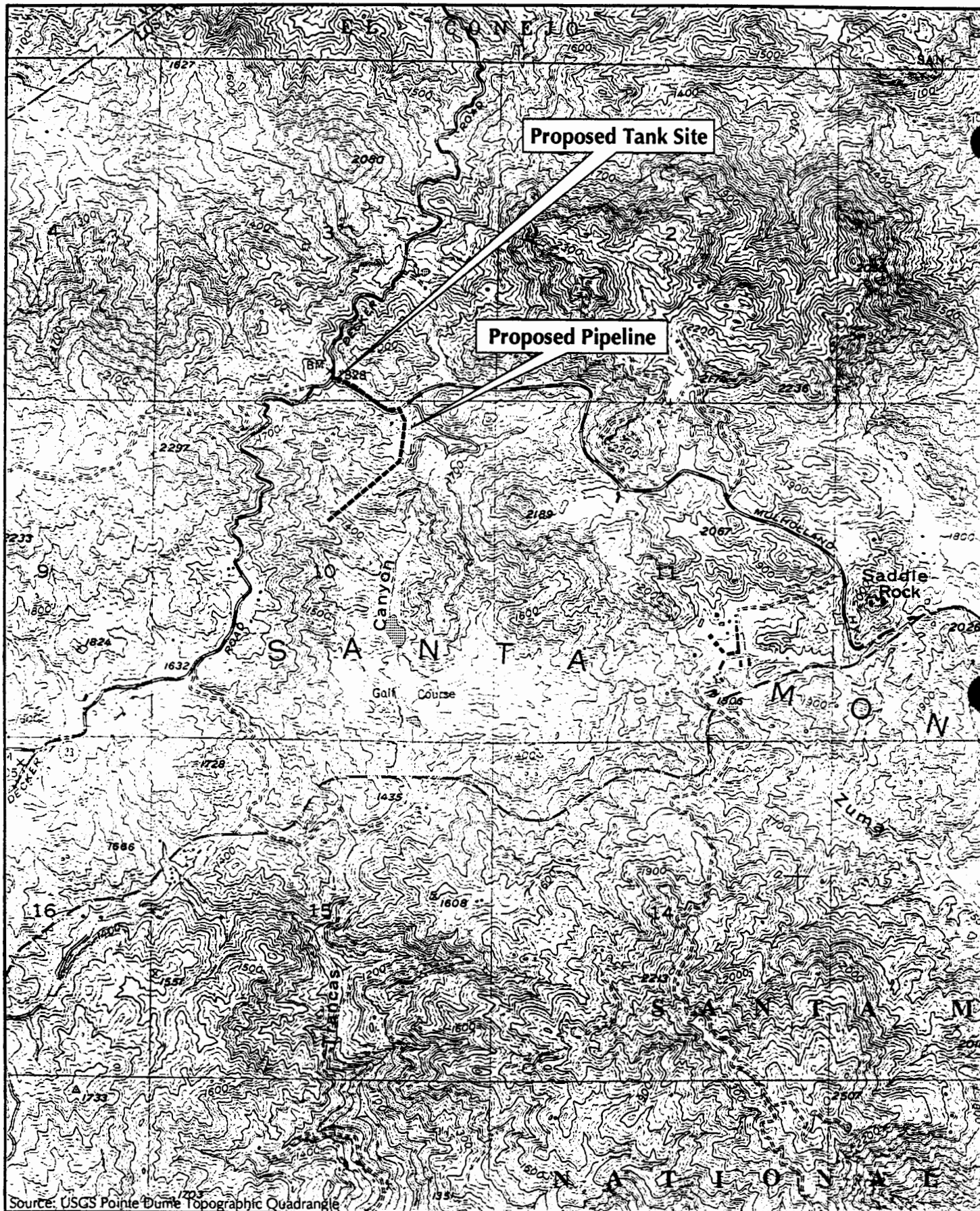

**Malibu Golf Course**  
**Vicinity Map**

<b>Exhibit 1</b>
<b>Permit 4-03-065</b>
<b>Vicinity Map</b>



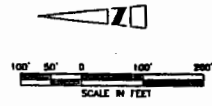
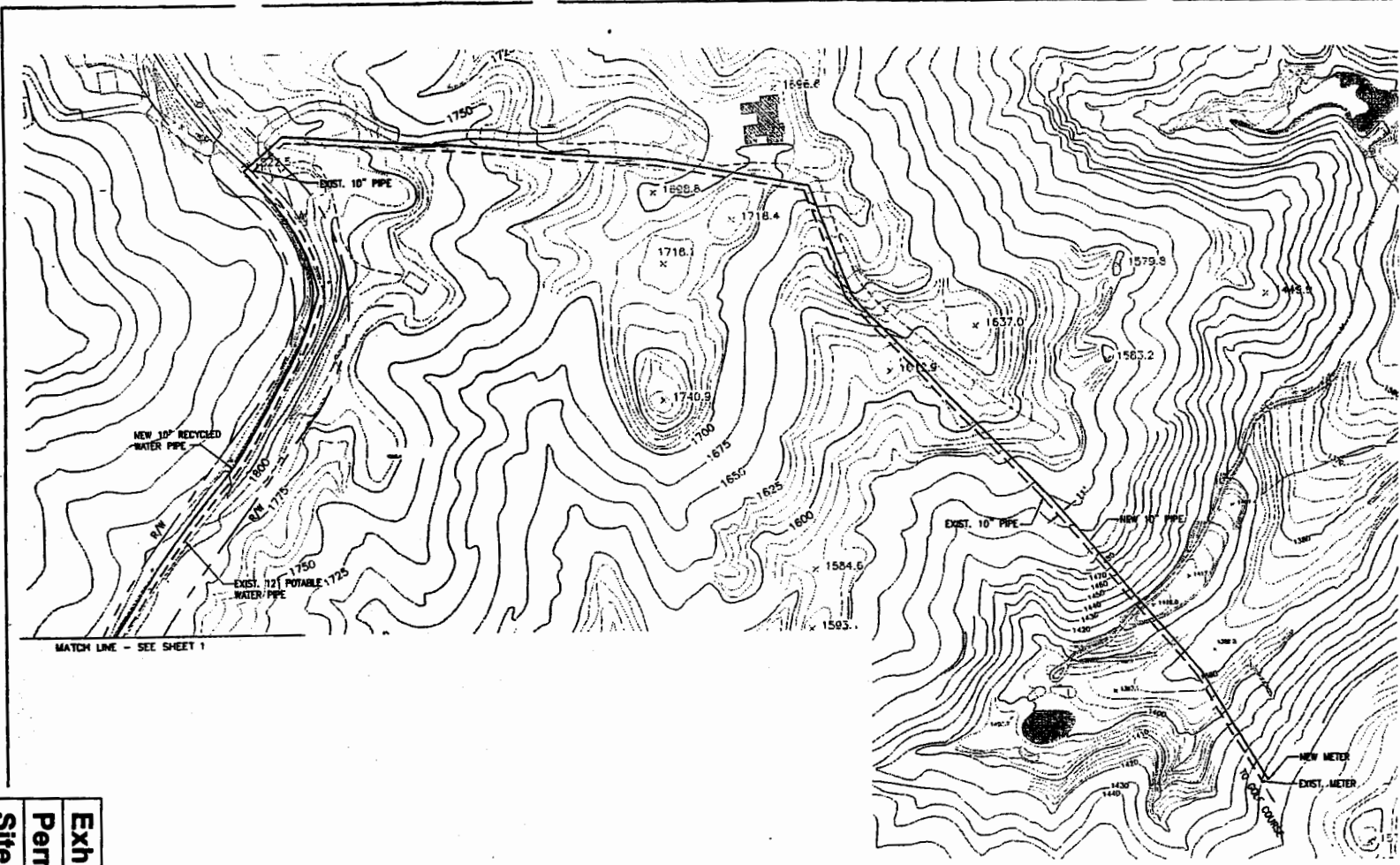

LAS VIRGENES MUNICIPAL WATER DISTRICT  
 MALIBU GOLF COURSE  
 RECYCLED WATER PROJECT  
 PIPE ALIGNMENT  
 GOLF COURSE SERVICE

**SEALS ENGINEERING CORPORATION**  
 1000 S. GARDEN AVENUE  
 ANAHEIM, CALIFORNIA 92810  
 PHONE: 714/933-8888  
 FAX: 714/933-8889  
 WWW: SEALS-ENGINEERING.COM

DRAFT 4/25/03

Exhibit 3  
 Permit 4-03-065  
 Site Plan—Pipeline

THIS DRAWING IS A SHEET ONLY

MATCH LINE - SEE SHEET 1

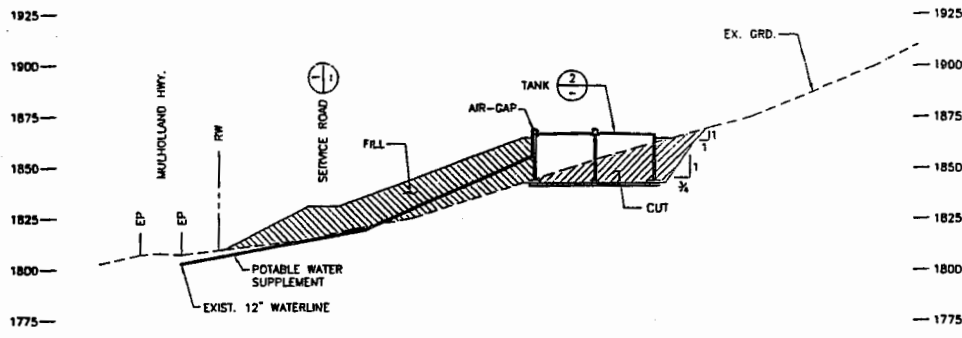

HORIZ. : 1" = 30'  
SCALE: VERT. : 1" = 30'

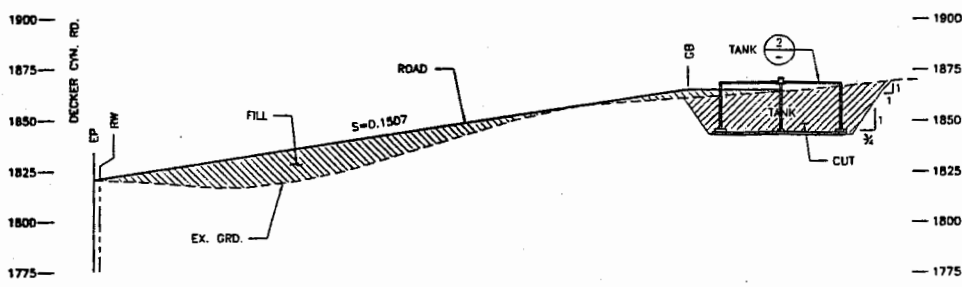

HORIZ. : 1" = 30'  
SCALE: VERT. : 1" = 30'

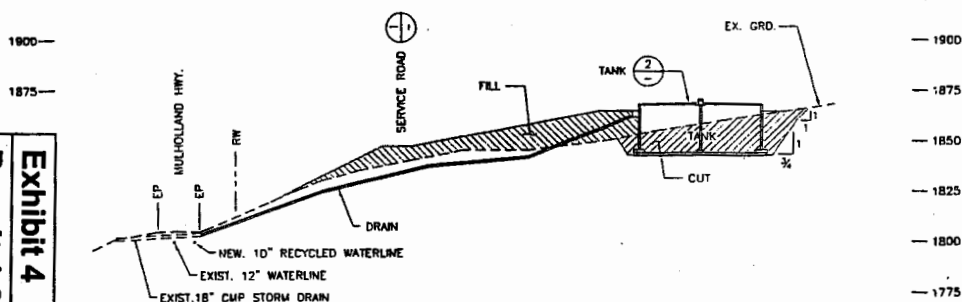

HORIZ. : 1" = 30'  
SCALE: VERT. : 1" = 30'

SCALES  
ON ORIGINAL DRAWING  
SHOWN IN THIS SHEET,  
AS ACCORDANT

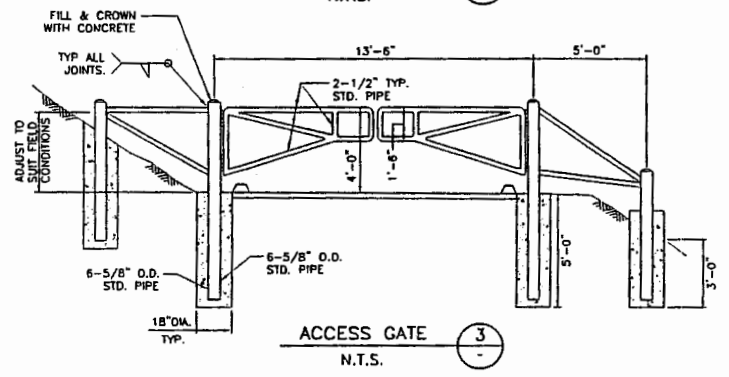
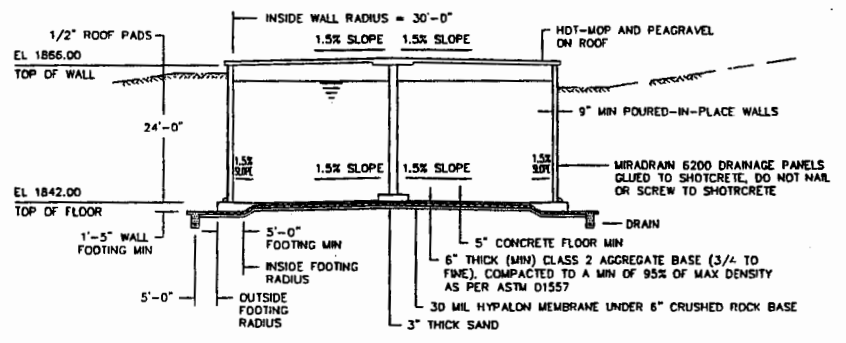
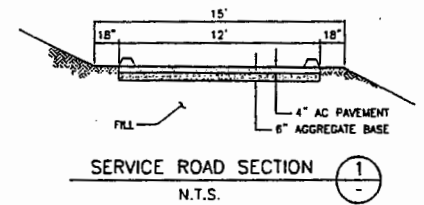

Exhibit 4  
 Permit 4-03-065  
 Cross Sections—Tank

LAS VIRGENES MUNICIPAL WATER DISTRICT  
MALIBU GOLF COURSE  
RECYCLED WATER PROJECT  
TANK SITE CONCEPTS  
PROFILES

SCOTT ENGINEERING & CONSTRUCTION  
REGISTERED ENGINEERS  
SINCE 1954

DRAFT 4/26/03		3	
---------------	--	---	--

B'

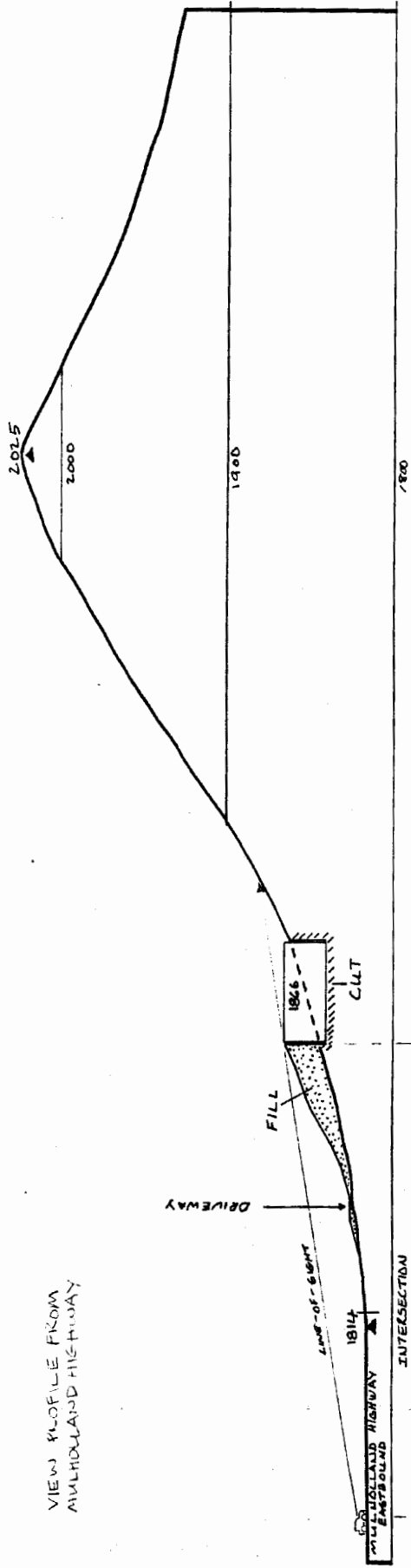

VIEW PROFILE FROM MULHOLLAND HIGHWAY

DISTANCE OF VIEW TO LOCATION OF CLOSEST EDGE OF WATER TANK  
WATER TANK NOT VISIBLE

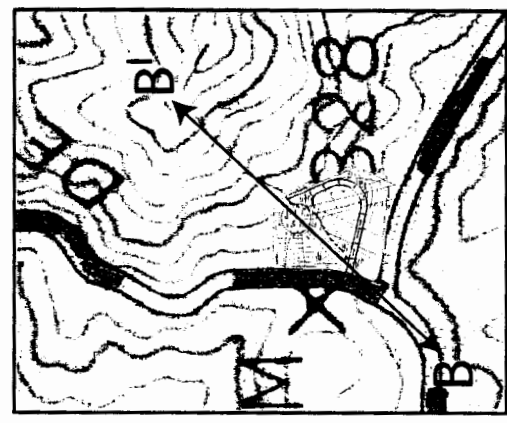

<b>Exhibit 5</b>
<b>Permit 4-03-065</b>
<b>Line of Sight (1 of 2)</b>

# Eastbound View Profile from Mulholland Highway

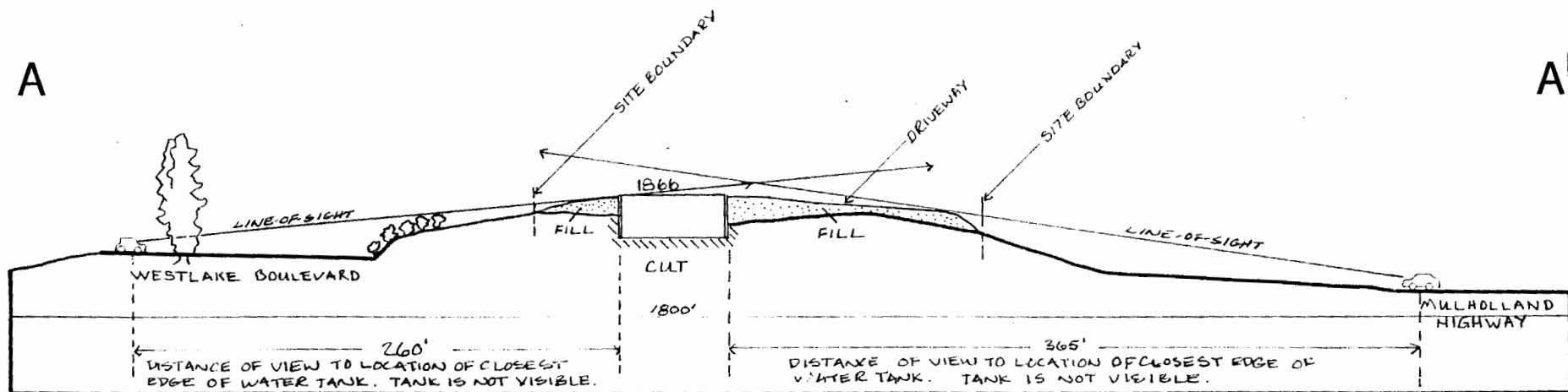

VIEW PROFILE FROM WESTLAKE  
BOULEVARD - Southbound

VIEW PROFILE FROM MULHOLLAND  
HIGHWAY - WESTBOUND

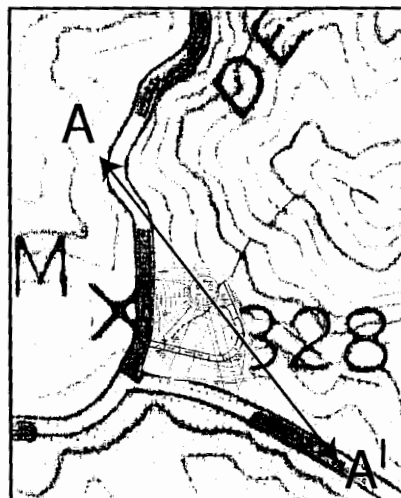

Exhibit 6  
Permit 4-03-065  
Line of Sight (2 of 2)

## CALIFORNIA COASTAL COMMISSION

45 FREMONT, SUITE 2000  
SAN FRANCISCO, CA 94105-2219  
VOICE AND TDD (415) 904-5200  
FAX (415) 904-5400



## MEMORANDUM

FROM: John Dixon, Ph.D.  
Ecologist / Wetland Coordinator

TO: Ventura Staff

SUBJECT: Designation of ESHA in the Santa Monica Mountains

DATE: March 25, 2003

---

In the context of the Malibu LCP, the Commission found that the Mediterranean Ecosystem in the Santa Mountains is rare, and especially valuable because of its relatively pristine character, physical complexity, and resultant biological diversity. Therefore, areas of undeveloped native habitat in the Santa Monica Mountains that are large and relatively unfragmented may meet the definition of ESHA by virtue of their valuable roles in that ecosystem, regardless of their relative rarity throughout the state. This is the only place in the coastal zone where the Commission has recognized chaparral as meeting the definition of ESHA. The scientific background presented herein for ESHA analysis in the Santa Monica Mountains is adapted from the Revised Findings for the Malibu LCP that the Commission adopted on February 6, 2003.

For habitats in the Santa Monica Mountains, particularly coastal sage scrub and chaparral, there are three site-specific tests to determine whether an area is ESHA because of its especially valuable role in the ecosystem. First, is the habitat properly identified, for example as coastal sage scrub or chaparral? The requisite information for this test generally should be provided by a site-specific biological assessment. Second, is the habitat largely undeveloped and otherwise relatively pristine? Third, is the habitat part of a large, contiguous block of relatively pristine native vegetation? This should be documented with an aerial photograph from our mapping unit (with the site delineated) and should be attached as an exhibit to the staff report. For those habitats that are absolutely rare or that support individual rare species, it is not necessary to find that they are relatively pristine, and are neither isolated nor fragmented.

**Designation of Environmentally Sensitive Habitat in the  
Santa Monica Mountains**

The Coastal Act provides a definition of "environmentally sensitive area" as: "Any area in which plant or animal life or their habitats are either rare or especially valuable because of their special nature or role in an ecosystem and which could be easily disturbed or degraded by human activities and developments" (Section 30107.5).

Exhibit 7

Permit 4-03-065



There are three important elements to the definition of ESHA. First, a geographic area can be designated ESHA either because of the presence of individual species of plants or animals or because of the presence of a particular habitat. Second, in order for an area to be designated as ESHA, the species or habitat must be either rare or it must be especially valuable. Finally, the area must be easily disturbed or degraded by human activities.

The first test of ESHA is whether a habitat or species is rare. Rarity can take several forms, each of which is important. Within the Santa Monica Mountains, rare species and habitats often fall within one of two common categories. Many rare species or habitats are globally rare, but locally abundant. They have suffered severe historical declines in overall abundance and currently are reduced to a small fraction of their original range, but where present may occur in relatively large numbers or cover large local areas. This is probably the most common form of rarity for both species and habitats in California and is characteristic of coastal sage scrub, for example. Some other habitats are geographically widespread, but occur everywhere in low abundance. California's native perennial grasslands fall within this category.

A second test for ESHA is whether a habitat or species is especially valuable. Areas may be valuable because of their "special nature," such as being an unusually pristine example of a habitat type, containing an unusual mix of species, supporting species at the edge of their range, or containing species with extreme variation. For example, reproducing populations of valley oaks are not only increasingly rare, but their southernmost occurrence is in the Santa Monica Mountains. Generally, however, habitats or species are considered valuable because of their special "role in the ecosystem." For example, many areas within the Santa Monica Mountains may meet this test because they provide habitat for endangered species, protect water quality, provide essential corridors linking one sensitive habitat to another, or provide critical ecological linkages such as the provision of pollinators or crucial trophic connections. Of course, all species play a role in their ecosystem that is arguably "special." However, the Coastal Act requires that this role be "especially valuable." This test is met for relatively pristine areas that are integral parts of the Santa Monica Mountains Mediterranean ecosystem because of the demonstrably rare and extraordinarily special nature of that ecosystem as detailed below.

Finally, ESHAs are those areas that could be easily disturbed or degraded by human activities and developments. Within the Santa Monica Mountains, as in most areas of southern California affected by urbanization, all natural habitats are in grave danger of direct loss or significant degradation as a result of many factors related to anthropogenic changes.

### **Ecosystem Context of the Habitats of the Santa Monica Mountains**

The Santa Monica Mountains comprise the largest, most pristine, and ecologically complex example of a Mediterranean ecosystem in coastal southern California.

California's coastal sage scrub, chaparral, oak woodlands, and associated riparian areas have analogues in just a few areas of the world with similar climate. Mediterranean ecosystems with their wet winters and warm dry summers are only found in five localities (the Mediterranean coast, California, Chile, South Africa, and south and southwest Australia). Throughout the world, this ecosystem with its specially adapted vegetation and wildlife has suffered severe loss and degradation from human development. Worldwide, only 18 percent of the Mediterranean community type remains undisturbed<sup>1</sup>. However, within the Santa Monica Mountains, this ecosystem is remarkably intact despite the fact that it is closely surrounded by some 17 million people. For example, the 150,000 acres of the Santa Monica Mountains National Recreation Area, which encompasses most of the Santa Monica Mountains, was estimated to be 90 percent free of development in 2000<sup>2</sup>. Therefore, this relatively pristine area is both large and mostly unfragmented, which fulfills a fundamental tenet of conservation biology<sup>3</sup>. The need for large contiguous areas of natural habitat in order to maintain critical ecological processes has been emphasized by many conservation biologists<sup>4</sup>.

In addition to being a large single expanse of land, the Santa Monica Mountains ecosystem is still connected, albeit somewhat tenuously, to adjacent, more inland ecosystems<sup>5</sup>. Connectivity among habitats within an ecosystem and connectivity among ecosystems is very important for the preservation of species and ecosystem integrity. In a recent statewide report, the California Resources Agency<sup>6</sup> identified wildlife corridors and habitat connectivity as the top conservation priority. In a letter to governor Gray Davis, sixty leading environmental scientists have endorsed the

---

<sup>1</sup> National Park Service. 2000. Draft general management plan & environmental impact statement. Santa Monica Mountains National Recreation Area – California.

<sup>2</sup> Ibid.

<sup>3</sup> Harris, L. D. 1988. Edge effects and conservation of biotic diversity. *Conserv. Biol.* 330-332. Soule, M. E., D. T. Bolger, A. C. Alberts, J. Wright, M. Soric and S. Hill. 1988. Reconstructed dynamics of rapid extinctions of chaparral-requiring birds in urban habitat islands. *Conserv. Biol.* 2: 75-92. Yahner, R. H. 1988. Changes in wildlife communities near edges. *Conserv. Biol.* 2:333-339. Murphy, D. D. 1989. Conservation and confusion: Wrong species, wrong scale, wrong conclusions. *Conservation Biol.* 3:82-84.

<sup>4</sup> Crooks, K. 2000. Mammalian carnivores as target species for conservation in Southern California. p. 105-112 in: Keeley, J. E., M. Baer-Keeley and C. J. Fotheringham (eds), 2<sup>nd</sup> Interface Between Ecology and Land Development in California, U.S. Geological Survey Open-File Report 00-62. Sauvajot, R. M., E. C. York, T. K. Fuller, H. Sharon Kim, D. A. Kamradt and R. K. Wayne. 2000. Distribution and status of carnivores in the Santa Monica Mountains, California: Preliminary results from radio telemetry and remote camera surveys. p 113-123 in: Keeley, J. E., M. Baer-Keeley and C. J. Fotheringham (eds), 2<sup>nd</sup> Interface Between Ecology and Land Development in California, U.S. Geological Survey Open-File Report 00-62. Beier, P. and R. F. Noss. 1998. Do habitat corridors provide connectivity? *Conserv. Biol.* 12:1241-1252. Beier, P. 1996. Metapopulation models, tenacious tracking and cougar conservation. In: *Metapopulations and Wildlife Conservation*, ed. D. R. McCullough. Island Press, Covelo, California, 429p.

<sup>5</sup> The SMM area is linked to larger natural inland areas to the north through two narrow corridors: 1) the Conejo Grade connection at the west end of the Mountains and 2) the Simi Hills connection in the central region of the SMM (from Malibu Creek State Park to the Santa Susanna Mountains).

<sup>6</sup> California Resources Agency. 2001. Missing Linkages: Restoring Connectivity to the California Landscape. California Wilderness Coalition, Calif. Dept of Parks & Recreation, USGS, San Diego Zoo and The Nature Conservancy. Available at: <http://www.calwild.org/pubs/reports/linkages/index.htm>

conclusions of that report<sup>7</sup>. The chief of natural resources at the California Department of Parks and Recreation has identified the Santa Monica Mountains as an area where maintaining connectivity is particularly important<sup>8</sup>.

The species most directly affected by large scale connectivity are those that require large areas or a variety of habitats, e.g., gray fox, cougar, bobcat, badger, steelhead trout, and mule deer<sup>9</sup>. Large terrestrial predators are particularly good indicators of habitat connectivity and of the general health of the ecosystem<sup>10</sup>. Recent studies show that the mountain lion, or cougar, is the most sensitive indicator species of habitat fragmentation, followed by the spotted skunk and the bobcat<sup>11</sup>. Sightings of cougars in both inland and coastal areas of the Santa Monica Mountains<sup>12</sup> demonstrate their continued presence. Like the "canary in the mineshaft," an indicator species like this is good evidence that habitat connectivity and large scale ecological function remains in the Santa Monica Mountains ecosystem.

The habitat integrity and connectivity that is still evident within the Santa Monica Mountains is extremely important to maintain, because both theory and experiments over 75 years in ecology confirm that large spatially connected habitats tend to be more stable and have less frequent extinctions than habitats without extended spatial structure<sup>13</sup>. Beyond simply destabilizing the ecosystem, fragmentation and disturbance

<sup>7</sup> Letters received and included in the September 2002 staff report for the Malibu LCP.

<sup>8</sup> Schoch, D. 2001. Survey lists 300 pathways as vital to state wildlife. Los Angeles Times. August 7, 2001.

<sup>9</sup> Martin, G. 2001. Linking habitat areas called vital for survival of state's wildlife. Scientists map main migration corridors. San Francisco Chronicle, August 7, 2001.

<sup>10</sup> Noss, R. F., H. B. Quigley, M. G. Hornocker, T. Merrill and P. C. Paquet. 1996. Conservation biology and carnivore conservation in the Rocky Mountains. *Conserv. Biol.* 10: 949-963. Noss, R. F. 1995. Maintaining ecological integrity in representative reserve networks. World Wildlife Fund Canada.

<sup>11</sup> Sauvajot, R. M., E. C. York, T. K. Fuller, H. Sharon Kim, D. A. Kamradt and R. K. Wayne. 2000. Distribution and status of carnivores in the Santa Monica Mountains, California: Preliminary results from radio telemetry and remote camera surveys. p 113-123 in: Keeley, J. E., M. Baer-Keeley and C. J. Fotheringham (eds), 2nd Interface Between Ecology and Land Development in California, U.S. Geological Survey Open-File Report 00-62. Beier, P. 1996. Metapopulation models, tenacious tracking and cougar conservation. In: *Metapopulations and Wildlife Conservation*, ed. D. R. McCullough. Island Press, Covelo, California, 429p.

<sup>12</sup> Recent sightings of mountain lions include: Temescal Canyon (pers. com., Peter Brown, Facilities Manager, Calvary Church), Topanga Canyon (pers. com., Marti Witter, NPS), Encinal and Trancas Canyons (pers. com., Pat Healy), Stump Ranch Research Center (pers. com., Dr. Robert Wayne, Dept. of Biology, UCLA). In May of 2002, the NPS *photographed* a mountain lion at a trip camera on the Back Bone Trail near Castro Crest – Seth Riley, Eric York and Dr. Ray Sauvajot, National Park Service, SMMNRA.

<sup>13</sup> Gause, G. F. 1934. *The struggle for existence*. Baltimore, William and Wilkins 163 p. (also reprinted by Hafner, N.Y. 1964). Gause, G. F., N. P. Smaragdova and A. A. Witt. 1936. Further studies of interaction between predators and their prey. *J. Anim. Ecol.* 5:1-18. Huffaker, C. B. 1958. Experimental studies on predation: dispersion factors and predator-prey oscillations. *Hilgardia* 27:343-383. Luckinbill, L. S. 1973. Coexistence in laboratory populations of *Paramecium aurelia* and its predator *Didinium nasutum*. *Ecology* 54:1320-1327. Allen, J. C., C. C. Brewster and D. H. Slone. 2001. Spatially explicit ecological models: A spatial convolution approach. *Chaos, Solitons and Fractals.* 12:333-347.

can even cause unexpected and irreversible changes to new and completely different kinds of ecosystems (habitat conversion)<sup>14</sup>.

As a result of the pristine nature of large areas of the Santa Monica Mountains and the existence of large, unfragmented and interconnected blocks of habitat, this ecosystem continues to support an extremely diverse flora and fauna. The observed diversity is probably a function of the diversity of physical habitats. The Santa Monica Mountains have the greatest geological diversity of all major mountain ranges within the transverse range province. According to the National Park Service, the Santa Monica Mountains contain 40 separate watersheds and over 170 major streams with 49 coastal outlets<sup>15</sup>. These streams are somewhat unique along the California coast because of their topographic setting. As a "transverse" range, the Santa Monica Mountains are oriented in an east-west direction. As a result, the south-facing riparian habitats have more variable sun exposure than the east-west riparian corridors of other sections of the coast. This creates a more diverse moisture environment and contributes to the higher biodiversity of the region. The many different physical habitats of the Santa Monica Mountains support at least 17 native vegetation types<sup>16</sup> including the following habitats considered sensitive by the California Department of Fish and Game: native perennial grassland, coastal sage scrub, red-shank chaparral, valley oak woodland, walnut woodland, southern willow scrub, southern cottonwood-willow riparian forest, sycamore-alder woodland, oak riparian forest, coastal salt marsh, and freshwater marsh. Over 400 species of birds, 35 species of reptiles and amphibians, and more than 40 species of mammals have been documented in this diverse ecosystem. More than 80 sensitive species of plants and animals (listed, proposed for listing, or species of concern) are known to occur or have the potential to occur within the Santa Monica Mountains Mediterranean ecosystem.

The Santa Monica Mountains are also important in a larger regional context. Several recent studies have concluded that the area of southern California that includes the Santa Monica Mountains is among the most sensitive in the world in terms of the number of rare endemic species, endangered species and habitat loss. These studies have designated the area to be a local hot-spot of endangerment in need of special protection<sup>17</sup>.

Therefore, the Commission finds that the Santa Monica Mountains ecosystem is itself rare and especially valuable because of its special nature as the largest, most pristine,

---

<sup>14</sup> Scheffer, M., S. Carpenter, J. A. Foley, C. Folke and B. Walker. 2001. Catastrophic shifts in ecosystems. *Nature* 413:591-596.

<sup>15</sup> NPS. 2000. op.cit.

<sup>16</sup> From the NPS report (2000 op. cit.) that is based on the older Holland system of subjective classification. The data-driven system of Sawyer and Keeler-Wolf results in a much larger number of distinct "alliances" or vegetation types.

<sup>17</sup> Myers, N. 1990. The biodiversity challenge: Expanded hot-spots analysis. *Environmentalist* 10:243-256. Myers, N., R. A. Mittermeier, C. G. Mittermeier, G. A. B. da Fonseca and J. A. Kent. 2000. Biodiversity hot-spots for conservation priorities. *Nature* 403:853-858. Dobson, A. P., J. P. Rodriguez, W. M. Roberts and D. S. Wilcove. 1997. Geographic distribution of endangered species in the United States. *Science* 275:550-553.

physically complex, and biologically diverse example of a Mediterranean ecosystem in coastal southern California. The Commission further finds that because of the rare and special nature of the Santa Monica Mountains ecosystem, the ecosystem roles of substantially intact areas of the constituent plant communities discussed below are "especially valuable" under the Coastal Act.

### **Major Habitats within the Santa Monica Mountains**

The most recent vegetation map that is available for the Santa Monica Mountains is the map that was produced for the National Park Service in the mid-1990s using 1993 satellite imagery supplemented with color and color infrared aerial imagery from 1984, 1988, and 1994 and field review<sup>18</sup>. The minimum mapping unit was 5 acres. For that map, the vegetation was mapped in very broad categories, generally following a vegetation classification scheme developed by Holland<sup>19</sup>. Because of the mapping methods used the degree of plant community complexity in the landscape is not represented. For example, the various types of "ceanothus chaparral" that have been documented were lumped under one vegetation type referred to as "northern mixed chaparral." Dr. Todd Keeler-Wolf of the California Department of Fish and Game is currently conducting a more detailed, quantitative vegetation survey of the Santa Monica Mountains.

The National Park Service map can be used to characterize broadly the types of plant communities present. The main generic plant communities present in the Santa Monica Mountains<sup>20</sup> are: coastal sage scrub, chaparral, riparian woodland, coast live oak woodland, and grasslands.

#### Riparian Woodland

Some 49 streams connect inland areas with the coast, and there are many smaller drainages as well, many of which are "blue line." Riparian woodlands occur along both perennial and intermittent streams in nutrient-rich soils. Partly because of its multi-layered vegetation, the riparian community contains the greatest overall biodiversity of all the plant communities in the area<sup>21</sup>. At least four types of riparian communities are discernable in the Santa Monica Mountains: walnut riparian areas, mulefat-dominated riparian areas, willow riparian areas and sycamore riparian woodlands. Of these, the

---

<sup>18</sup> Franklin, J. 1997. Forest Service Southern California Mapping Project, Santa Monica Mountains National Recreation Area, Task 11 Description and Results, Final Report. June 13, 1997, Dept. of Geography, San Diego State University, USFS Contract No. 53-91S8-3-TM45.

<sup>19</sup> Holland R. F. 1986. Preliminary Descriptions of the Terrestrial Natural Communities of California. State of California, The Resources Agency, Dept. of Fish and Game, Natural Heritage Division, Sacramento, CA. 95814.

<sup>20</sup> National Park Service. 2000. Draft: General Management Plan & Environmental Impact Statement, Santa Monica Mountains National Recreation Area, US Dept. of Interior, National Park Service, December 2000. (Fig. 11 in this document.)

<sup>21</sup> Ibid.

sycamore riparian woodland is the most diverse riparian community in the area. In these habitats, the dominant plant species include arroyo willow, California black walnut, sycamore, coast live oak, Mexican elderberry, California bay laurel, and mule fat. Wildlife species that have been observed in this community include least Bell's vireo (a State and federally listed species), American goldfinches, black phoebes, warbling vireos, bank swallows (State listed threatened species), song sparrows, belted kingfishers, raccoons, and California and Pacific tree frogs.

Riparian communities are the most species-rich to be found in the Santa Monica Mountains. Because of their multi-layered vegetation, available water supply, vegetative cover and adjacency to shrubland habitats, they are attractive to many native wildlife species, and provide essential functions in their lifecycles<sup>22</sup>. During the long dry summers in this Mediterranean climate, these communities are an essential refuge and oasis for much of the areas' wildlife.

Riparian habitats and their associated streams form important connecting links in the Santa Monica Mountains. These habitats connect all of the biological communities from the highest elevation chaparral to the sea with a unidirectional flowing water system, one function of which is to carry nutrients through the ecosystem to the benefit of many different species along the way.

The streams themselves provide refuge for sensitive species including: the coast range newt, the Pacific pond turtle, and the steelhead trout. The coast range newt and the Pacific pond turtle are California Species of Special Concern and are proposed for federal listing<sup>23</sup>, and the steelhead trout is federally endangered. The health of the streams is dependent on the ecological functions provided by the associated riparian woodlands. These functions include the provision of large woody debris for habitat, shading that controls water temperature, and input of leaves that provide the foundation of the stream-based trophic structure.

The importance of the connectivity between riparian areas and adjacent habitats is illustrated by the Pacific pond turtle and the coast range newt, both of which are sensitive and both of which require this connectivity for their survival. The life history of the Pacific pond turtle demonstrates the importance of riparian areas and their associated watersheds for this species. These turtles require the stream habitat during the wet season. However, recent radio tracking work<sup>24</sup> has found that although the Pacific pond turtle spends the wet season in streams, it also requires upland habitat for refuge during the dry season. Thus, in coastal southern California, the Pacific pond turtle requires both streams and intact adjacent upland habitats such as coastal sage

---

<sup>22</sup> Walter, Hartmut. Bird use of Mediterranean habitats in the Santa Monica Mountains, Coastal Commission Workshop on the Significance of Native Habitats in the Santa Monica Mountains. CCC Hearing, June 13, 2002, Queen Mary Hotel.

<sup>23</sup> USFWS. 1989. Endangered and threatened wildlife and plants; animal notice of review. Fed. Reg. 54:554-579. USFWS. 1993. Endangered and threatened wildlife and plants; notice of 1-year petition finding on the western pond turtle. Fed. Reg. 58:42717-42718.

<sup>24</sup> Rathbun, G.B., N.J. Scott and T.G. Murphy. 2002. Terrestrial habitat use by Pacific pond turtle in a Mediterranean climate. *Southwestern Naturalist*. (in Press).

scrub, woodlands or chaparral as part of their normal life cycle. The turtles spend about four months of the year in upland refuge sites located an average distance of 50 m (but up to 280 m) from the edge of the creek bed. Similarly, nesting sites where the females lay eggs are also located in upland habitats an average of 30 m (but up to 170 m) from the creek. Occasionally, these turtles move up to 2 miles across upland habitat<sup>25</sup>. Like many species, the pond turtle requires both stream habitats and the upland habitats of the watershed to complete its normal annual cycle of behavior. Similarly, the coast range newt has been observed to travel hundreds of meters into upland habitat and spend about ten months of the year far from the riparian streambed<sup>26</sup>. They return to the stream to breed in the wet season, and they are therefore another species that requires both riparian habitat and adjacent uplands for their survival.

Riparian habitats in California have suffered serious losses and such habitats in southern California are currently very rare and seriously threatened. In 1989, Faber estimated that 95-97% of riparian habitat in southern California was already lost<sup>27</sup>. Writing at the same time as Faber, Bowler asserted that, "[t]here is no question that riparian habitat in southern California is endangered."<sup>28</sup> In the intervening 13 years, there have been continuing losses of the small amount of riparian woodlands that remain. Today these habitats are, along with native grasslands and wetlands, among the most threatened in California.

In addition to direct habitat loss, streams and riparian areas have been degraded by the effects of development. For example, the coast range newt, a California Species of Special Concern has suffered a variety of impacts from human-related disturbances<sup>29</sup>. Human-caused increased fire frequency has resulted in increased sedimentation rates, which exacerbates the cannibalistic predation of adult newts on the larval stages.<sup>30</sup> In addition impacts from non-native species of crayfish and mosquito fish have also been documented. When these non-native predators are introduced, native prey organisms are exposed to new mortality pressures for which they are not adapted. Coast range newts that breed in the Santa Monica Mountain streams do not appear to have adaptations that permit co-occurrence with introduced mosquito fish and crayfish<sup>31</sup>. These introduced predators have eliminated the newts from streams where they previously occurred by both direct predation and suppression of breeding.

<sup>25</sup> Testimony by R. Dagit, Resource Conservation District of the Santa Monica Mountains at the CCC Habitat Workshop on June 13, 2002.

<sup>26</sup> Dr. Lee Kats, Pepperdine University, personal communication to Dr J. Allen, CCC.

<sup>27</sup> Faber, P.A., E. Keller, A. Sands and B.M. Massey. 1989. The ecology of riparian habitats of the southern California coastal region: a community profile. U.S. Fish and Wildlife Service Biological Report 85(7.27) 152pp.

<sup>28</sup> Bowler, P.A. 1989. Riparian woodland: An endangered habitat in southern California. Pp 80-97 in Schoenherr, A.A. (ed.) Endangered plant communities of southern California. Botanists Special Publication No. 3.

<sup>29</sup> Gamradt, S.C., L.B. Kats and C.B. Anzalone. 1997. Aggression by non-native crayfish deters breeding in California newts. *Conservation Biology* 11(3):793-796.

<sup>30</sup> Kerby, L.J., and L.B. Kats. 1998. Modified interactions between salamander life stages caused by wildfire-induced sedimentation. *Ecology* 79(2):740-745.

<sup>31</sup> Gamradt, S.C. and L.B. Kats. 1996. Effect of introduced crayfish and mosquitofish on California newts. *Conservation Biology* 10(4):1155-1162.

Therefore, because of the essential role that riparian plant communities play in maintaining the biodiversity of the Santa Monica Mountains, because of the historical losses and current rarity of these habitats in southern California, and because of their extreme sensitivity to disturbance, the native riparian habitats in the Santa Monica Mountains meet the definition of ESHA under the Coastal Act.

### Coastal Sage Scrub and Chaparral

Coastal sage scrub and chaparral are often lumped together as "shrublands" because of their roughly similar appearance and occurrence in similar and often adjacent physical habitats. In earlier literature, these vegetation associations were often called soft chaparral and hard chaparral, respectively. "Soft" and "hard" refers to differences in their foliage associated with different adaptations to summer drought. Coastal sage scrub is dominated by soft-leaved, generally low-growing aromatic shrubs that die back and drop their leaves in response to drought. Chaparral is dominated by taller, deeper-rooted evergreen shrubs with hard, waxy leaves that minimize water loss during drought.

The two vegetation types are often found interspersed with each other. Under some circumstances, coastal sage scrub may even be successional to chaparral, meaning that after disturbance, a site may first be covered by coastal sage scrub, which is then replaced with chaparral over long periods of time.<sup>32</sup> The existing mosaic of coastal sage scrub and chaparral is the result of a dynamic process that is a function of fire history, recent climatic conditions, soil differences, slope, aspect and moisture regime, and the two habitats should not be thought of as completely separate and unrelated entities but as different phases of the same process<sup>33</sup>. The spatial pattern of these vegetation stands at any given time thus depends on both local site conditions and on history (e.g., fire), and is influenced by both natural and human factors.

In lower elevation areas with high fire frequency, chaparral and coastal sage scrub may be in a state of flux, leading one researcher to describe the mix as a "coastal sage-chaparral subclimax."<sup>34</sup> Several other researchers have noted the replacement of chaparral by coastal sage scrub, or coastal sage scrub by chaparral depending on fire history.<sup>35</sup> In transitional and other settings, the mosaic of chaparral and coastal sage

---

<sup>32</sup> Cooper, W.S. 1922. The broad-sclerophyll vegetation of California. Carnegie Institution of Washington Publication 319. 124 pp.

<sup>33</sup> Longcore, T and C. Rich. 2002. Protection of environmentally sensitive habitat areas in proposed local coastal plan for the Santa Monica Mountains. The Urban Wildlands Group, Inc., P.O. Box 24020 Los Angeles, CA 90024. (See attached comment document in Appendix).

<sup>34</sup> Hanes, T.L. 1965. Ecological studies on two closely related chaparral shrubs in southern California. Ecological Monographs 41:27-52.

<sup>35</sup> Gray, K.L. 1983. Competition for light and dynamic boundary between chaparral and coastal sage scrub. Madrono 30(1):43-49. Zedler, P.H., C.R. Gautier and G.S. McMaster. 1983. Vegetation change in response to extreme events: The effect of a short interval between fires in California chaparral and coastal sage scrub. Ecology 64(4): 809-818.



scrub enriches the seasonal plant resource base and provides additional habitat variability and seasonality for the many species that inhabit the area.

### Relationships Among Coastal Sage Scrub, Chaparral and Riparian Communities

Although the constituent communities of the Santa Monica Mountains Mediterranean ecosystem can be defined and distinguished based on species composition, growth habits, and the physical habitats they characteristically occupy, they are not independent entities ecologically. Many species of plants, such as black sage, and laurel sumac, occur in more than one plant community and many animals rely on the predictable mix of communities found in undisturbed Mediterranean ecosystems to sustain them through the seasons and during different portions of their life histories.

Strong evidence for the interconnectedness between chaparral, coastal scrub and other habitats is provided by "opportunistic foragers" (animals that follow the growth and flowering cycles across these habitats). Coastal scrub and chaparral flowering and growth cycles differ in a complimentary and sequential way that many animals have evolved to exploit. Whereas coastal sage scrub is shallow-rooted and responds quickly to seasonal rains, chaparral plants are typically deep-rooted having most of their flowering and growth later in the rainy season after the deeper soil layers have been saturated<sup>36</sup>. New growth of chaparral evergreen shrubs takes place about four months later than coastal sage scrub plants and it continues later into the summer<sup>37</sup>. For example, in coastal sage scrub, California sagebrush flowers and grows from August to February and coyote bush flowers from August to November<sup>38</sup>. In contrast, chamise chaparral and bigpod ceanothus flower from April to June, buck brush ceanothus flowers from February to April, and hoaryleaf ceanothus flowers from March to April.

Many groups of animals exploit these seasonal differences in growth and blooming period. The opportunistic foraging insect community (e.g., honeybees, butterflies and moths) tends to follow these cycles of flowering and new growth<sup>39</sup>, moving from coastal sage scrub in the early rainy season to chaparral in the spring<sup>39</sup>. The insects in turn are followed by insectivorous birds such as the blue-gray gnatcatcher<sup>40</sup>, bushtit, cactus wren, Bewick's wren and California towhee. At night bats take over the role of daytime insectivores. At least 12 species of bats (all of which are considered sensitive) occur in

---

<sup>36</sup> DeSimone, S. 2000. California's coastal sage scrub. *Fremontia* 23(4):3-8. Mooney, H.A. 1988. Southern coastal scrub. Chap. 13 in Barbour, M.G. and J. Majors; Eds. 1988. *Terrestrial vegetation of California*, 2<sup>nd</sup> Edition. Calif. Native Plant Soc. Spec. Publ. #9.

<sup>37</sup> Schoenherr, A. A. 1992. *A natural history of California*. University of California Press, Berkeley. 772p.

<sup>38</sup> Dale, N. 2000. Flowering plants of the Santa Monica Mountains. California Native Plant Society, 1722 J Street, Suite 17, Sacramento, CA 95814.

<sup>39</sup> Ballmer, G. R. 1995. What's bugging coastal sage scrub. *Fremontia* 23(4):17-26.

<sup>40</sup> Root, R. B. 1967. The niche exploitation pattern of the blue-gray gnatcatcher. *Ecol. Monog.* 37:317-350.

the Santa Monica Mountains<sup>41</sup>. Five species of hummingbirds also follow the flowering cycle<sup>42</sup>.

Many species of 'opportunistic foragers', which utilize several different community types, perform important ecological roles during their seasonal movements. The scrub jay is a good example of such a species. The scrub jay is an omnivore and forages in coastal sage scrub, chaparral, and oak woodlands for insects, berries and notably acorns. Its foraging behavior includes the habit of burying acorns, usually at sites away from the parent tree canopy. Buried acorns have a much better chance of successful germination (about two-fold) than exposed acorns because they are protected from desiccation and predators. One scrub jay will bury approximately 5000 acorns in a year. The scrub jay therefore performs the function of greatly increasing recruitment and regeneration of oak woodland, a valuable and sensitive habitat type<sup>43</sup>.

Like the scrub jay, most of the species of birds that inhabit the Mediterranean ecosystem in the Santa Monica Mountains require more than one community type in order to flourish. Many species include several community types in their daily activities. Other species tend to move from one community to another seasonally. The importance of maintaining the integrity of the multi-community ecosystem is clear in the following observations of Dr. Hartmut Walter of the University of California at Los Angeles:

"Bird diversity is directly related to the habitat mosaic and topographic diversity of the Santa Monicas. Most bird species in this bio-landscape require more than one habitat for survival and reproduction." "A significant proportion of the avifauna breeds in the wooded canyons of the Santa Monicas. Most of the canyon breeders forage every day in the brush- and grass-covered slopes, ridges and mesas. They would not breed in the canyons in the absence of the surrounding shrublands. Hawks, owls, falcons, orioles, flycatchers, woodpeckers, warblers, hummingbirds, etc. belong to this group. Conversely, some of the characteristic chaparral birds such as thrashers, quails, and wrentits need the canyons for access to shelter, protection from fire, and water. The regular and massive movement of birds between riparian corridors and adjacent shrublands has been demonstrated by qualitative and quantitative observations by several UCLA students<sup>44</sup>."

Thus, the Mediterranean ecosystem of the Santa Monica Mountains is a mosaic of vegetation types linked together ecologically. The high biodiversity of the area results

---

<sup>41</sup> Letter from Dr. Marti Witter, NPS, dated Sept. 13, 2001, in letters received and included in the September 2002 staff report for the Malibu LCP.

<sup>42</sup> National Park Service. 1993. A checklist of the birds of the Santa Monica Mountains National Recreation Area. Southwest Parks and Monuments Assoc., 221 N. Court, Tucson, AZ. 85701

<sup>43</sup> Borchert, M. I., F. W. Davis, J. Michaelsen and L. D. Oyler. 1989. Interactions of factors affecting seedling recruitment of blue oak (*Quercus douglasii*) in California. *Ecology* 70:389-404. Bossema, I. 1979. Jays and oaks: An eco-ethological study of a symbiosis. *Behavior* 70:1-118. Schoenherr, A. A. 1992. A natural history of California. University of California Press, Berkeley. 772p.

<sup>44</sup> Walter, Hartmut. Bird use of Mediterranean habitats in the Santa Monica Mountains, Coastal Commission Workshop on the Significance of Native Habitats in the Santa Monica Mountains. CCC Hearing, June 13, 2002, Queen Mary Hotel.

from both the diversity and the interconnected nature of this mosaic. Most raptor species, for example, require large areas and will often require different habitats for perching, nesting and foraging. Fourteen species of raptors (13 of which are considered sensitive) are reported from the Santa Monica Mountains. These species utilize a variety of habitats including rock outcrops, oak woodlands, riparian areas, grasslands, chaparral, coastal sage scrub, estuaries and freshwater lakes<sup>45</sup>.

When the community mosaic is disrupted and fragmented by development, many chaparral-associated native bird species are impacted. In a study of landscape-level fragmentation in the Santa Monica Mountains, Stralberg<sup>46</sup> found that the ash-throated flycatcher, Bewick's wren, wrentit, blue-gray gnatcatcher, California thrasher, orange-crowned warbler, rufous-crowned sparrow, spotted towhee, and California towhee all decreased in numbers as a result of urbanization. Soule<sup>47</sup> observed similar effects of fragmentation on chaparral and coastal sage scrub birds in the San Diego area.

In summary, all of the vegetation types in this ecosystem are strongly linked by animal movement and foraging. Whereas classification and mapping of vegetation types may suggest a snapshot view of the system, the seasonal movements and foraging of animals across these habitats illustrates the dynamic nature and vital connections that are crucial to the survival of this ecosystem.

### Coastal Sage Scrub

"Coastal sage scrub" is a generic vegetation type that is inclusive of several subtypes<sup>48</sup>. In the Santa Monica Mountains, coastal sage scrub is mostly of the type termed "Venturan Coastal Sage Scrub." In general, coastal sage scrub is comprised of dominant species that are semi-woody and low-growing, with shallow, dense roots that enable them to respond quickly to rainfall. Under the moist conditions of winter and spring, they grow quickly, flower, and produce light, wind-dispersed seeds, making them good colonizers following disturbance. These species cope with summer drought by dying back, dropping their leaves or producing a smaller summer leaf in order to reduce water loss. Stands of coastal sage scrub are much more open than chaparral and contain a greater admixture of herbaceous species. Coastal sage scrub is generally restricted to drier sites, such as low foothills, south-facing slopes, and shallow soils at higher elevations.

---

<sup>45</sup> National Park Service. 1993. A checklist of the birds of the Santa Monica Mountains National Recreation Area. Southwest Parks and Monuments Assoc., 221 N. Court, Tucson, AZ. 85701. and Letter from Dr. Marti Witter, NPS, Dated Sept. 13, 2001, in letters received and included in the September 2002 staff report for the Malibu LCP.

<sup>46</sup> Stralberg, D. 2000. Landscape-level urbanization effects on chaparral birds: A Santa Monica Mountains case study. p 125-136 in: Keeley, J. E., M. Baer-Keeley and C. J. Fotheringham (eds), 2<sup>nd</sup> Interface Between Ecology and Land Development in California, U.S. Geological Survey Open-File Report 00-62.

<sup>47</sup> Soule, M. E, D. T. Bolger, A. C. Alberts, J. Wright, M. Sorice and S. Hill. 1988. Reconstructed dynamics of rapid extinctions of chaparral-requiring birds in urban habitat islands. *Conserv. Biol.* 2: 75-92.

<sup>48</sup> Kirkpatrick, J.B. and C.F. Hutchinson. 1977. The community composition of Californian coastal sage scrub. *Vegetatio* 35:21-33; Holland, 1986. op.cit.; Sawyer and Keeler-Wolf, 1995, op.cit.

The species composition and structure of individual stands of coastal sage scrub depend on moisture conditions that derive from slope, aspect, elevation and soil type. Drier sites are dominated by more drought-resistant species (e.g., California sagebrush, coast buckwheat, and *Opuntia* cactus). Where more moisture is available (e.g., north-facing slopes), larger evergreen species such as toyon, laurel sumac, lemonade berry, and sugar bush are common. As a result, there is more cover for wildlife, and movement of large animals from chaparral into coastal sage scrub is facilitated in these areas. Characteristic wildlife in this community includes Anna's hummingbirds, rufous-sided towhees, California quail, greater roadrunners, Bewick's wrens, coyotes, and coast horned lizards<sup>49</sup>, but most of these species move between coastal sage scrub and chaparral during their daily activities or on a seasonal basis.

Of the many important ecosystem roles performed by the coastal sage scrub community, five are particularly important in the Santa Monica Mountains. Coastal sage scrub provides critical linkages between riparian corridors, provides essential habitat for species that require several habitat types during the course of their life histories, provides essential habitat for local endemics, supports rare species that are in danger of extinction, and reduces erosion, thereby protecting the water quality of coastal streams.

Riparian woodlands are primary contributors to the high biodiversity of the Santa Monica Mountains. The ecological integrity of those riparian habitats not only requires wildlife dispersal along the streams, but also depends on the ability of animals to move from one riparian area to another. Such movement requires that the riparian corridors be connected by suitable habitat. In the Santa Monica Mountains, coastal sage scrub and chaparral provide that function. Significant development in coastal sage scrub would reduce the riparian corridors to linear islands of habitat with severe edge effects<sup>50</sup>, reduced diversity, and lower productivity.

Most wildlife species and many species of plants utilize several types of habitat. Many species of animals endemic to Mediterranean habitats move among several plant communities during their daily activities and many are reliant on different communities either seasonally or during different stages of their life cycle. Without an intact mosaic of coastal sage scrub, chaparral, and riparian community types, many species will not thrive. Specific examples of the importance of interconnected communities, or habitats, were provided in the discussion above. This is an essential ecosystem role of coastal sage scrub.

A characteristic of the coastal sage scrub vegetation type is a high degree of endemism. This is consonant with Westman's observation that 44 percent of the species he sampled in coastal sage scrub occurred at only one of his 67 sites, which were

---

<sup>49</sup> National Park Service. 2000. Draft: General Management Plan & Environmental Impact Statement, Santa Monica Mountains National Recreation Area, US Dept. of Interior, National Park Service, December 2000.

<sup>50</sup> Environmental impacts are particularly severe at the interface between development and natural habitats. The greater the amount of this "edge" relative to the area of natural habitat, the worse the impact.

distributed from the San Francisco Bay area to Mexico<sup>51</sup>. Species with restricted distributions are by nature more susceptible to loss or degradation of their habitat. Westman said of this unique and local aspect of coastal sage scrub species in California:

"While there are about 50 widespread sage scrub species, more than half of the 375 species encountered in the present study of the sage scrub flora are rare in occurrence within the habitat range. In view of the reduction of the area of coastal sage scrub in California to 10-15% of its former extent and the limited extent of preserves, measures to conserve the diversity of the flora are needed."<sup>52</sup>

Coastal sage scrub in southern California provides habitat for about 100 rare species<sup>53</sup>, many of which are also endemic to limited geographic regions<sup>54</sup>. In the Santa Monica Mountains, rare animals that inhabit coastal sage scrub<sup>55</sup> include the Santa Monica shieldback katydid, silvery legless lizard, coastal cactus wren, Bell's sparrow, San Diego desert woodrat, southern California rufous-crowned sparrow, coastal western whiptail, and San Diego horned lizard. Some of these species are also found in chaparral<sup>56</sup>. Rare plants found in coastal sage scrub in the Santa Monica Mountains include Santa Susana tarplant, Coulter's saltbush, Blockman's dudleya, Braunton's milkvetch, Parry's spineflower, and Plummer's mariposa lily<sup>57</sup>. A total of 32 sensitive species of reptiles, birds and mammals have been identified in this community by the National Park Service.<sup>58</sup>

One of the most important ecological functions of coastal sage scrub in the Santa Monica Mountains is to protect water quality in coastal streams by reducing erosion in the watershed. Although shallow rooted, the shrubs that define coastal sage scrub have dense root masses that hold the surface soils much more effectively than the exotic annual grasses and forbs that tend to dominate in disturbed areas. The native shrubs of this community are resistant not only to drought, as discussed above, but well adapted to fire. Most of the semi-woody shrubs have some ability to crown sprout after

---

<sup>51</sup> Westman, W.E. 1981. Diversity relations and succession in Californian coastal sage scrub. *Ecology* 62:170-184.

<sup>52</sup> Ibid.

<sup>53</sup> Atwood, J. L. 1993. California gnatcatchers and coastal sage scrub: The biological basis for endangered species listing. pp.149-166 *In: Interface Between Ecology and Land Development in California*. Ed. J. E. Keeley, So. Calif. Acad. of Sci., Los Angeles. California Department of Fish and Game (CDFG). 1993. The Southern California Coastal Sage Scrub (CSS) Natural Communities Conservation Plan (NCCP). CDFG and Calif. Resources Agency, 1416 9<sup>th</sup> St., Sacramento, CA 95814.

<sup>54</sup> Westman, W.E. 1981. op. cit.

<sup>55</sup> Biological Resources Assessment of the Proposed Santa Monica Mountains Significant Ecological Area. Nov. 2000. Los Angeles Co., Dept. of Regional Planning, 320 West Temple St., Rm. 1383, Los Angeles, CA 90012.

<sup>56</sup> O'Leary J.F., S.A. DeSimone, D.D. Murphy, P.F. Brussard, M.S. Gilpin, and R.F. Noss. 1994. Bibliographies on coastal sage scrub and related malacophyllous shrublands of other Mediterranean-type climates. *California Wildlife Conservation Bulletin* 10:1-51.

<sup>57</sup> Biological Resources Assessment of the Proposed Santa Monica Mountains Significant Ecological Area. Nov. 2000. Los Angeles Co., Dept. of Regional Planning, 320 West Temple St., Rm. 1383, Los Angeles, CA 90012.

<sup>58</sup> NPS, 2000, op cit.

fire. Several CSS species (e.g., *Eriogonum cinereum*) in the Santa Monica Mountains and adjacent areas resprout vigorously and other species growing near the coast demonstrate this characteristic more strongly than do individuals of the same species growing at inland sites in Riverside County.<sup>59</sup> These shrub species also tend to recolonize rapidly from seed following fire. As a result they provide persistent cover that reduces erosion.

In addition to performing extremely important roles in the Mediterranean ecosystem, the coastal sage scrub community type has been drastically reduced in area by habitat loss to development. In the early 1980's it was estimated that 85 to 90 percent of the original extent of coastal sage scrub in California had already been destroyed.<sup>60</sup> Losses since that time have been significant and particularly severe in the coastal zone.

Therefore, because of its increasing rarity, its important role in the functioning of the Santa Monica Mountains Mediterranean ecosystem, and its extreme vulnerability to development, coastal sage scrub within the Santa Monica Mountains meets the definition of ESHA under the Coastal Act.

### Chaparral

Another shrub community in the Santa Monica Mountain Mediterranean ecosystem is chaparral. Like "coastal sage scrub," this is a generic category of vegetation. Chaparral species have deep roots (10s of ft) and hard waxy leaves, adaptations to drought that increase water supply and decrease water loss at the leaf surface. Some chaparral species cope more effectively with drought conditions than do desert plants<sup>61</sup>. Chaparral plants vary from about one to four meters tall and form dense, intertwining stands with nearly 100 percent ground cover. As a result, there are few herbaceous species present in mature stands. Chaparral is well adapted to fire. Many species regenerate mainly by crown sprouting; others rely on seeds which are stimulated to germinate by the heat and ash from fires. Over 100 evergreen shrubs may be found in chaparral<sup>62</sup>. On average, chaparral is found in wetter habitats than coastal sage scrub, being more common at higher elevations and on north facing slopes.

The broad category "northern mixed chaparral" is the major type of chaparral shown in the National Park Service map of the Santa Monica Mountains. However, northern mixed chaparral can be variously dominated by chamise, scrub oak or one of several species of manzanita or by ceanothus. In addition, it commonly contains woody vines and large shrubs such as mountain mahogany, toyon, hollyleaf redberry, and sugarbush<sup>63</sup>. The rare red shank chaparral plant community also occurs in the Santa Monica Mountains. Although included within the category "northern mixed chaparral" in

<sup>59</sup> Dr. John O'Leary, SDSU, personal communication to Dr. John Dixon, CCC, July 2, 2002

<sup>60</sup> Westman, W.E. 1981. op. cit.

<sup>61</sup> Dr. Stephen Davis, Pepperdine University. Presentation at the CCC workshop on the significance of native habitats in the Santa Monica Mountains. June 13, 2002.

<sup>62</sup> Keely, J.E. and S.C. Keeley. Chaparral. Pages 166-207 in M.G. Barbour and W.D. Billings, eds. North American Terrestrial Vegetation. New York, Cambridge University Press.

<sup>63</sup> Ibid.

the vegetation map, several types of ceanothus chaparral are reported in the Santa Monica Mountains. Ceanothus chaparral occurs on stable slopes and ridges, and may be dominated by bigpod ceanothus, buck brush ceanothus, hoaryleaf ceanothus, or greenbark ceanothus. In addition to ceanothus, other species that are usually present in varying amounts are chamise, black sage, holly-leaf redberry, sugarbush, and coast golden bush<sup>64</sup>.

Several sensitive plant species that occur in the chaparral of the Santa Monica Mountains area are: Santa Susana tarplant, Lyon's pentachaeta, marcescent dudleya, Santa Monica Mountains dudleya, Braunton's milk vetch and salt spring checkerbloom<sup>65</sup>. Several occurring or potentially occurring sensitive animal species in chaparral from the area are: Santa Monica shieldback katydid, western spadefoot toad, silvery legless lizard, San Bernardino ring-neck snake, San Diego mountain kingsnake, coast patch-nosed snake, sharp-shinned hawk, southern California rufous-crowned sparrow, Bell's sparrow, yellow warbler, pallid bat, long-legged myotis bat, western mastiff bat, and San Diego desert woodrat.<sup>66</sup>

Coastal sage scrub and chaparral are the predominant generic community types of the Santa Monica Mountains and provide the living matrix within which rarer habitats like riparian woodlands exist. These two shrub communities share many important ecosystem roles. Like coastal sage scrub, chaparral within the Santa Monica Mountains provides critical linkages among riparian corridors, provides essential habitat for species that require several habitat types during the course of their life histories, provides essential habitat for sensitive species, and stabilizes steep slopes and reduces erosion, thereby protecting the water quality of coastal streams.

Many species of animals in Mediterranean habitats characteristically move among several plant communities during their daily activities, and many are reliant on different communities either seasonally or during different stages of their life cycle. The importance of an intact mosaic of coastal sage scrub, chaparral, and riparian community types is perhaps most critical for birds. However, the same principles apply to other taxonomic groups. For example, whereas coastal sage scrub supports a higher diversity of native ant species than chaparral, chaparral habitat is necessary for the coast horned lizard, an ant specialist<sup>67</sup>. Additional examples of the importance of an interconnected communities, or habitats, were provided in the discussion of coastal sage scrub above. This is an extremely important ecosystem role of chaparral in the Santa Monica Mountains.

Chaparral is also remarkably adapted to control erosion, especially on steep slopes. The root systems of chaparral plants are very deep, extending far below the surface and

---

<sup>64</sup> Ibid.

<sup>65</sup> Biological Resources Assessment of the Proposed Santa Monica Mountains Significant Ecological Area. Nov. 2000. Los Angeles Co., Dept. of Regional Planning, 320 West Temple St., Rm. 1383, Los Angeles, CA 90012.

<sup>66</sup> Ibid.

<sup>67</sup> A.V. Suarez. Ants and lizards in coastal sage scrub and chaparral. A presentation at the CCC workshop on the significance of native habitats in the Santa Monica Mountains. June 13, 2002.

penetrating the bedrock below<sup>68</sup>, so chaparral literally holds the hillsides together and prevents slippage.<sup>69</sup> In addition, the direct soil erosion from precipitation is also greatly reduced by 1) water interception on the leaves and above ground foliage and plant structures, and 2) slowing the runoff of water across the soil surface and providing greater soil infiltration. Chaparral plants are extremely resistant to drought, which enables them to persist on steep slopes even during long periods of adverse conditions. Many other species die under such conditions, leaving the slopes unprotected when rains return. Since chaparral plants recover rapidly from fire, they quickly re-exert their ground stabilizing influence following burns. The effectiveness of chaparral for erosion control after fire increases rapidly with time<sup>70</sup>. Thus, the erosion from a 2-inch rain-day event drops from 5 yd<sup>3</sup>/acre of soil one year after a fire to 1 yd<sup>3</sup>/acre after 4 years.<sup>71</sup> The following table illustrates the strong protective effect of chaparral in preventing erosion.

Soil erosion as a function of 24-hour precipitation and chaparral age.

Years Since Fire	Erosion (yd <sup>3</sup> /acre) at Maximum 24-hr Precipitation of:		
	2 inches	5 inches	11 inches
1	5	20	180
4	1	12	140
17	0	1	28
50+	0	0	3

Therefore, because of its important roles in the functioning of the Santa Monica Mountains Mediterranean ecosystem, and its extreme vulnerability to development, chaparral within the Santa Monica Mountains meets the definition of ESHA under the Coastal Act.

### Oak Woodland and Savanna

Coast live oak woodland occurs mostly on north slopes, shaded ravines and canyon bottoms. Besides the coast live oak, this plant community includes hollyleaf cherry, California bay laurel, coffeeberry, and poison oak. Coast live oak woodland is more

<sup>68</sup> Helmers, H., J.S. Horton, G. Juhren and J. O'Keefe. 1955. Root systems of some chaparral plants in southern California. *Ecology* 36(4):667-678. Kummerow, J. and W. Jow. 1977. Root systems of chaparral shrubs. *Oecologia* 29:163-177.

<sup>69</sup> Radtke, K. 1983. *Living more safely in the chaparral-urban interface*. General Technical Report PSW-67. U.S. Department of Agriculture, Forest Service, Pacific Southwest Research Station, Berkeley, California. 51 pp.

<sup>70</sup> Kittredge, J. 1973. *Forest influences — the effects of woody vegetation on climate, water, and soil*. Dover Publications, New York. 394 pp. Longcore, T and C. Rich. 2002. Protection of environmentally sensitive habitat areas in proposed local coastal plan for the Santa Monica Mountains. (Table 1). The Urban Wildlands Group, Inc., P.O. Box 24020 Los Angeles, CA 90024. Vicars, M. (ed.) 1999. *FireSmart: protecting your community from wildfire*. Partners in Protection, Edmonton, Alberta.

<sup>71</sup> *Ibid.*



tolerant of salt-laden fog than other oaks and is generally found nearer the coast<sup>72</sup>. Coast live oak also occurs as a riparian corridor species within the Santa Monica Mountains.

Valley oaks are endemic to California and reach their southern most extent in the Santa Monica Mountains. Valley oaks were once widely distributed throughout California's perennial grasslands in central and coastal valleys. Individuals of this species may survive 400-600 years. Over the past 150 years, valley oak savanna habitat has been drastically reduced and altered due to agricultural and residential development. The understory is now dominated by annual grasses and recruitment of seedlings is generally poor. This is a very threatened habitat.

The important ecosystem functions of oak woodlands and savanna are widely recognized<sup>73</sup>. These habitats support a high diversity of birds<sup>74</sup>, and provide refuge for many species of sensitive bats<sup>75</sup>. Typical wildlife in this habitat includes acorn woodpeckers, scrub jays, plain titmice, northern flickers, cooper's hawks, western screech owls, mule deer, gray foxes, ground squirrels, jackrabbits and several species of sensitive bats.

Therefore, because of their important ecosystem functions and vulnerability to development, oak woodlands and savanna within the Santa Monica Mountains met the definition of ESHA under the Coastal Act.

### Grasslands

Grasslands consist of low herbaceous vegetation that is dominated by grass species but may also harbor native or non-native forbs.

### California Perennial Grassland

Native grassland within the Santa Monica Mountains consists of perennial native needlegrasses: purple needlegrass, (*Nassella pulchra*), foothills needlegrass, (*Nassella lepida*) and nodding needlegrass (*Nassella cernua*). These grasses may occur in the same general area but they do not typically mix, tending to segregate based on slope

---

<sup>72</sup> NPS 2000. op. cit.

<sup>73</sup> Block, W.M., M.L. Morrison, and J. Verner. 1990. Wildlife and oak-woodland interdependency. *Fremontia* 18(3):72-76. Pavlik, B.M., P.C. Muick, S. Johnson, and M. Popper. 1991. *Oaks of California*. Cachuma Press and California Oak Foundation, Los Olivos, California. 184 pp.

<sup>74</sup> Cody, M.L. 1977. Birds. Pp. 223-231 in Throver, N.J.W., and D.E. Bradbury (eds.). *Chile-California Mediterranean scrub atlas*. US/IBP Synthesis Series 2. Dowden, Hutchinson & Ross, Stroudsburg, Pennsylvania. National Park Service. 1993. A checklist of the birds of the Santa Monica Mountains National Recreation Area. Southwest Parks and Monuments Assoc., 221 N. Court, Tucson, AZ. 85701

<sup>75</sup> Miner, K.L., and D.C. Stokes. 2000. Status, conservation issues, and research needs for bats in the south coast bioregion. Paper presented at *Planning for biodiversity: bringing research and management together*, February 29, California State University, Pomona, California.

and substrate factors<sup>76</sup>. Mixed with these native needlegrasses are many non-native annual species that are characteristic of California annual grassland<sup>77</sup>. Native perennial grasslands are now exceedingly rare<sup>78</sup>. In California, native grasslands once covered nearly 20 percent of the land area, but today are reduced to less than 0.1 percent<sup>79</sup>. The California Natural Diversity Database (CNDDDB) lists purple needlegrass habitat as a community needing priority monitoring and restoration. The CNDDDB considers grasslands with 10 percent or more cover by purple needlegrass to be significant, and recommends that these be protected as remnants of original California prairie. Patches of this sensitive habitat occur throughout the Santa Monica Mountains where they are intermingled with coastal sage scrub, chaparral and oak woodlands.

Many of the raptors that inhabit the Santa Monica Mountains make use of grasslands for foraging because they provide essential habitat for small mammals and other prey. Grasslands adjacent to woodlands are particularly attractive to these birds of prey since they simultaneously offer perching and foraging habitat. Particularly noteworthy in this regard are the white-tailed kite, northern harrier, sharp-shinned hawk, Cooper's hawk, red-shouldered hawk, red-tailed hawk, golden eagle, American kestrel, merlin, and prairie falcon<sup>80</sup>.

Therefore, because of their extreme rarity, important ecosystem functions, and vulnerability to development, California native perennial grasslands within the Santa Monica Mountains meet the definition of ESHA under the Coastal Act.

### California Annual Grassland

The term "California annual grassland" has been proposed to recognize the fact that non-native annual grasses should now be considered naturalized and a permanent feature of the California landscape and should be acknowledged as providing important ecological functions. These habitats support large populations of small mammals and provide essential foraging habitat for many species of birds of prey. California annual grassland generally consists of dominant invasive annual grasses that are primarily of Mediterranean origin. The dominant species in this community include common wild oats (*Avena fatua*), slender oat (*Avena barbata*), red brome (*Bromus madritensis* ssp. *Rubens*), riggut brome, (*Bromus diandrus*), and herbs such as black mustard (*Brassica nigra*), wild radish (*Raphanus sativus*) and sweet fennel (*Foeniculum vulgare*). Annual grasslands are located in patches throughout the Santa Monica Mountains in previously disturbed areas, cattle pastures, valley bottoms and along roadsides. While many of

---

<sup>76</sup> Sawyer, J. O. and T. Keeler-Wolf. 1995. A manual of California vegetation. California Native Plant Society, 1722 J St., Suite 17, Sacramento, CA 95814.

<sup>77</sup> Biological Resources Assessment of the Proposed Santa Monica Mountains Significant Ecological Area. Nov. 2000. Los Angeles Co., Dept. of Regional Planning, 320 West Temple St., Rm. 1383, Los Angeles, CA 90012.

<sup>78</sup> Noss, R.F., E.T. LaRoe III and J.M. Scott. 1995. Endangered ecosystems of the United States: a preliminary assessment of loss and degradation. Biological Report 28. National Biological Service, U.S. Dept. of Interior.

<sup>79</sup> NPS 2000. op. cit.

<sup>80</sup> NPS 2000. op. cit.

these patches are dominated by invasive non-native species, it would be premature to say that they are never sensitive or do not harbor valuable annual native species. A large number of native forbs also may be present in these habitats<sup>81</sup>, and many native wildflowers occur primarily in annual grasslands. In addition, annual grasslands are primary foraging areas for many sensitive raptor species in the area.

Inspection of California annual grasslands should be done prior to any impacts to determine if any rare native species are present or if any rare wildlife rely on the habitat and to determine if the site meets the Coastal Act ESHA criteria.

### **Effects of Human Activities and Development on Habitats within the Santa Monica Mountains**

The natural habitats of the Santa Monica Mountains are highly threatened by current development pressure, fragmentation and impacts from the surrounding megalopolis. The developed portions of the Santa Monica Mountains represents the extension of this urbanization into natural areas. About 54% of the undeveloped Santa Monica Mountains are in private ownership<sup>82</sup>, and computer simulation studies of the development patterns over the next 25 years predict a serious increase in habitat fragmentation<sup>83</sup>. Development and associated human activities have many well-documented deleterious effects on natural communities. These environmental impacts may be both direct and indirect and include the effects of increased fire frequency, of fire clearance, of introduction of exotic species, and of night lighting.

#### Increased Fire Frequency

Since 1925, all the major fires in the Santa Monica Mountains have been caused by human activities<sup>84</sup>. Increased fire frequency alters plant communities by creating conditions that select for some species over others. Strong resprouting plant species such as laurel sumac, are favored while non-sprouters like bigpod ceanothus, are at a disadvantage. Frequent fire recurrence before the non-sprouters can develop and reestablish a seed bank is detrimental, so that with each fire their chances for propagation are further reduced. Resprouters can be sending up new shoots quickly, and so they are favored in an increased fire frequency regime. Also favored are weedy and invasive species. Dr. Steven Davis in his abstract for a Coastal Commission

---

<sup>81</sup> Holstein, G. 2001. Pre-agricultural grassland in Central California. *Madrono* 48(4):253-264. Stromberg, M.R., P. Kephart and V. Yadon. 2001. Composition, invasibility and diversity of coastal California grasslands. *Madrono* 48(4):236-252.

<sup>82</sup> National Park Service. 2000. Draft: General Management Plan & Environmental Impact Statement, Santa Monica Mountains National Recreation Area, US Dept. of Interior, National Park Service, December 2000.

<sup>83</sup> Swenson, J. J., and J. Franklin. 2000. The effects of future urban development on habitat fragmentation in the Santa Monica Mountains. *Landscape Ecol.* 15:713-730.

<sup>84</sup> NPS, 2000, op. cit.

Workshop stated<sup>85</sup> *"We have evidence that recent increases in fire frequency has eliminated drought-hardy non-sprouters from chaparral communities near Malibu, facilitating the invasion of exotic grasses and forbs that further exacerbate fire frequency."* Thus, simply increasing fire frequency from about once every 22 years (the historical frequency) to about once every 12 years (the current frequency) can completely change the vegetation community. This has cascading effects throughout the ecosystem.

### Fuel Clearance

The removal of vegetation for fire protection in the Santa Monica Mountains is required by law in "Very High Fire Hazard Severity Zones"<sup>86</sup>. Fuel removal is reinforced by insurance carriers<sup>87</sup>. Generally, the Santa Monica Mountains are considered to be a high fire hazard severity zone. In such high fire hazard areas, homeowners must often resort to the California FAIR Plan to obtain insurance. Because of the high risk, all homes in "brush areas" are assessed an insurance surcharge if they have less than the recommended 200-foot fuel modification zone<sup>88</sup> around the home. The combination of insurance incentives and regulation assures that the 200-foot clearance zone will be applied universally<sup>89</sup>. While it is not required that all of this zone be cleared of vegetation, the common practice is simply to disk this zone, essentially removing or highly modifying all native vegetation. For a new structure not adjacent to existing structures, this results in the removal or modification of a minimum of three acres of vegetation<sup>90</sup>. While the directly impacted area is large, the effects of fuel modification extend beyond the 200-foot clearance area.

### Effects of Fuel Clearance on Bird Communities

The impacts of fuel clearance on bird communities was studied by Stralberg who identified three ecological categories of birds in the Santa Monica Mountains: 1) local and long distance migrators (ash-throated flycatcher, Pacific-slope flycatcher, phainopepla, black-headed grosbeak), 2) chaparral-associated species (Bewick's wren, wrentit, blue-gray gnatcatcher, California thrasher, orange-crowned warbler, rufous-crowned sparrow, spotted towhee, California towhee) and 3) urban-associated species

---

<sup>85</sup> Davis, Steven. Effects of fire and other factors on patterns of chaparral in the Santa Monica Mountains, Coastal Commission Workshop on the Significance of Native Habitats in the Santa Monica Mountains. CCC Hearing, June 13, 2002, Queen Mary Hotel.

<sup>86</sup> 1996 Los Angeles County Fire Code Section 1117.2.1

<sup>87</sup> Longcore, T and C. Rich. 2002. Protection of environmentally sensitive habitat areas in proposed local coastal plan for the Santa Monica Mountains. The Urban Wildlands Group, Inc., P.O. Box 24020 Los Angeles, CA 90024. Vicars, M. (ed.) 1999. FireSmart: protecting your community from wildfire. Partners in Protection, Edmonton, Alberta.

<sup>88</sup> Fuel Modification Plan Guidelines. Co. of Los Angeles Fire Department, Fuel Modification Unit, Prevention Bureau, Forestry Division, Brush Clearance Section, January 1998.

<sup>89</sup> Longcore, T and C. Rich. 2002. Protection of environmentally sensitive habitat areas in proposed local coastal plan for the Santa Monica Mountains. The Urban Wildlands Group, Inc., P.O. Box 24020 Los Angeles, CA 90024.

<sup>90</sup> Ibid.

(mourning dove, American crow, Western scrub-jay, Northern mockingbird)<sup>91</sup>. It was found in this study that the number of migrators and chaparral-associated species decreased due to habitat fragmentation while the abundance of urban-associated species increased. The impact of fuel clearance is to greatly increase this edge-effect of fragmentation by expanding the amount of cleared area and "edge" many-fold. Similar results of decreases in fragmentation-sensitive bird species are reported from the work of Bolger et al. in southern California chaparral<sup>92</sup>.

### Effects of Fuel Clearance on Arthropod Communities

Fuel clearance and habitat modification may also disrupt native arthropod communities, and this can have surprising effects far beyond the cleared area on species seemingly unrelated to the direct impacts. A particularly interesting and well-documented example with ants and lizards illustrates this point. When non-native landscaping with intensive irrigation is introduced, the area becomes favorable for the invasive and non-native Argentine ant. This ant forms "super colonies" that can forage more than 650 feet out into the surrounding native chaparral or coastal sage scrub around the landscaped area<sup>93</sup>. The Argentine ant competes with native harvester ants and carpenter ants displacing them from the habitat<sup>94</sup>. These native ants are the primary food resource for the native coast horned lizard, a California "Species of Special Concern." As a result of Argentine ant invasion, the coast horned lizard and its native ant food resources are diminished in areas near landscaped and irrigated developments<sup>95</sup>. In addition to specific effects on the coast horned lizard, there are other Mediterranean habitat ecosystem processes that are impacted by Argentine ant invasion through impacts on long-evolved native ant-plant mutualisms<sup>96</sup>. The composition of the whole arthropod community changes and biodiversity decreases when habitats are subjected to fuel modification. In coastal sage scrub disturbed by fuel modification, fewer arthropod

<sup>91</sup> Stralberg, D. 2000. Landscape-level urbanization effects on chaparral birds: a Santa Monica Mountains case study. Pp. 125-136 in Keeley, J.E., M. Baer-Keeley, and C.J. Fotheringham (eds.). *2nd interface between ecology and land development in California*. U.S. Geological Survey, Sacramento, California.

<sup>92</sup> Bolger, D. T., T. A. Scott and J. T. Rotenberry. 1997. Breeding bird abundance in an urbanizing landscape in coastal Southern California. *Conserv. Biol.* 11:406-421.

<sup>93</sup> Suarez, A.V., D.T. Bolger and T.J. Case. 1998. Effects of fragmentation and invasion on native ant communities in coastal southern California. *Ecology* 79(6):2041-2056.

<sup>94</sup> Holway, D.A. 1995. The distribution of the Argentine ant (*Linepithema humile*) in central California: a twenty-year record of invasion. *Conservation Biology* 9:1634-1637. Human, K.G. and D.M. Gordon. 1996. Exploitation and interference competition between the invasive Argentine ant, (*Linepithema humile*), and native ant species. *Oecologia* 105:405-412.

<sup>95</sup> Fisher, R.N., A.V. Suarez and T.J. Case. 2002. Spatial patterns in the abundance of the coastal horned lizard. *Conservation Biology* 16(1):205-215. Suarez, A.V. J.Q. Richmond and T.J. Case. 2000. Prey selection in horned lizards following the invasion of Argentine ants in southern California. *Ecological Applications* 10(3):711-725.

<sup>96</sup> Suarez, A.V., D.T. Bolger and T.J. Case. 1998. Effects of fragmentation and invasion on native ant communities in coastal southern California. *Ecology* 79(6):2041-2056. Bond, W. and P. Slingsby. Collapse of an Ant-Plant Mutualism: The Argentine Ant (*Iridomyrmex humilis*) and Myrmecochorous Proteaceae. *Ecology* 65(4):1031-1037.

predator species are seen and more exotic arthropod species are present than in undisturbed habitats<sup>97</sup>.

Studies in the Mediterranean vegetation of South Africa (equivalent to California shrubland with similar plant species) have shown how the invasive Argentine ant can disrupt the whole ecosystem.<sup>98</sup> In South Africa the Argentine ant displaces native ants as they do in California. Because the native ants are no longer present to collect and bury seeds, the seeds of the native plants are exposed to predation, and consumed by seed eating insects, birds and mammals. When this habitat burns after Argentine ant invasion the large-seeded plants that were protected by the native ants all but disappear. So the invasion of a non-native ant species drives out native ants, and this can cause a dramatic change in the species composition of the plant community by disrupting long-established seed dispersal mutualisms. In California, some insect eggs are adapted to being buried by native ants in a manner similar to plant seeds<sup>99</sup>.

### Artificial Night Lighting

One of the more recently recognized human impacts on ecosystem function is that of artificial night lighting as it effects the behavior and function of many different types of organisms<sup>100</sup>. For literally billions of years the only nighttime sources of light were the moon and stars, and living things have adapted to this previously immutable standard and often depend upon it for their survival. A review of lighting impacts suggests that whereas some species are unaffected by artificial night lighting, many others are severely impacted. Overall, most impacts are negative ones or ones whose outcome is unknown. Research to date has found negative impacts to plants, aquatic and terrestrial invertebrates, amphibians, fish, birds and mammals, and a detailed literature review can be found in the report by Longcore and Rich<sup>101</sup>.

### **Summary**

In a past action, the Coastal Commission found<sup>102</sup> that the Santa Monica Mountains Mediterranean Ecosystem, which includes the undeveloped native habitats of the Santa Monica Mountains, is rare and especially valuable because of its relatively pristine

<sup>97</sup> Longcore, T.R. 1999. Terrestrial arthropods as indicators of restoration success in coastal sage scrub. Ph.D. Dissertation, University of California, Los Angeles.

<sup>98</sup> Christian, C. 2001. Consequences of a biological invasion reveal the importance of mutualism for plant communities. *Nature* 413:635-639.

<sup>99</sup> Hughes, L. and M. Westoby. 1992. Capitula on stick insect eggs and elaiosomes on seeds: convergent adaptations for burial by ants. *Functional Ecology* 6:642-648.

<sup>100</sup> Longcore, T and C. Rich. 2002. Protection of environmentally sensitive habitat areas in proposed local coastal plan for the Santa Monica Mountains. The Urban Wildlands Group, Inc., P.O. Box 24020 Los Angeles, CA 90024.

<sup>101</sup> Ibid, and Ecological Consequences of Artificial Night Lighting, Conference, February 23-24, 2002, UCLA Los Angeles, California.

<sup>102</sup> Revised Findings for the City of Malibu Local Coastal Program (as adopted on September 13, 2002) adopted on February 6, 2003.

character, physical complexity, and resultant biological diversity. The undeveloped native habitats within the Santa Monica Mountains that are discussed above are ESHA because of their valuable roles in that ecosystem, including providing a critical mosaic of habitats required by many species of birds, mammals and other groups of wildlife, providing the opportunity for unrestricted wildlife movement among habitats, supporting populations of rare species, and preventing the erosion of steep slopes and thereby protecting riparian corridors, streams and, ultimately, shallow marine waters.

The importance the native habitats in the Santa Monica Mountains was emphasized nearly 20 years ago by the California Department of Fish and Game<sup>103</sup>. Commenting on a Draft Land Use Plan for the City of Malibu, the Regional Manager wrote that, "It is essential that large areas of land be reclassified to reflect their true status as ESHAs. One of the major needs of the Malibu LUP is that it should provide protection for entire drainages and not just stream bottoms." These conclusions were supported by the following observations:

"It is a fact that many of the wildlife species of the Santa Monica Mountains, such as mountain lion, deer, and raccoon, have established access routes through the mountains. They often travel to and from riparian zones and development such as high density residential may adversely affect a wildlife corridor.

Most animal species that exist in riparian areas will, as part of their life histories, also be found in other habitat types, including chaparral (sic) or grassland. For example, hawks nest and roost in riparian areas, but are dependent on large open areas for foraging. For the survival of many species, particularly those high on the food chain, survival will depend upon the presence of such areas. Such areas in the Santa Monica Mountains include grassland and coastal sage scrub communities, which have been documented in the SEA studies as supporting a wide diversity of plant and animal life."

This analysis by the Department of Fish and Game is consonant with the findings of the Commission in the case of the Malibu LCP, and with the conclusion that large contiguous areas of relatively pristine native habitat in the Santa Monica Mountains meet the definition of ESHA under the Coastal Act.

---

<sup>103</sup> Letter from F. A. Worthley, Jr. (CDFG) to N. Lucast (CCC) re Land Use Plan for Malibu dated March 22, 1983.

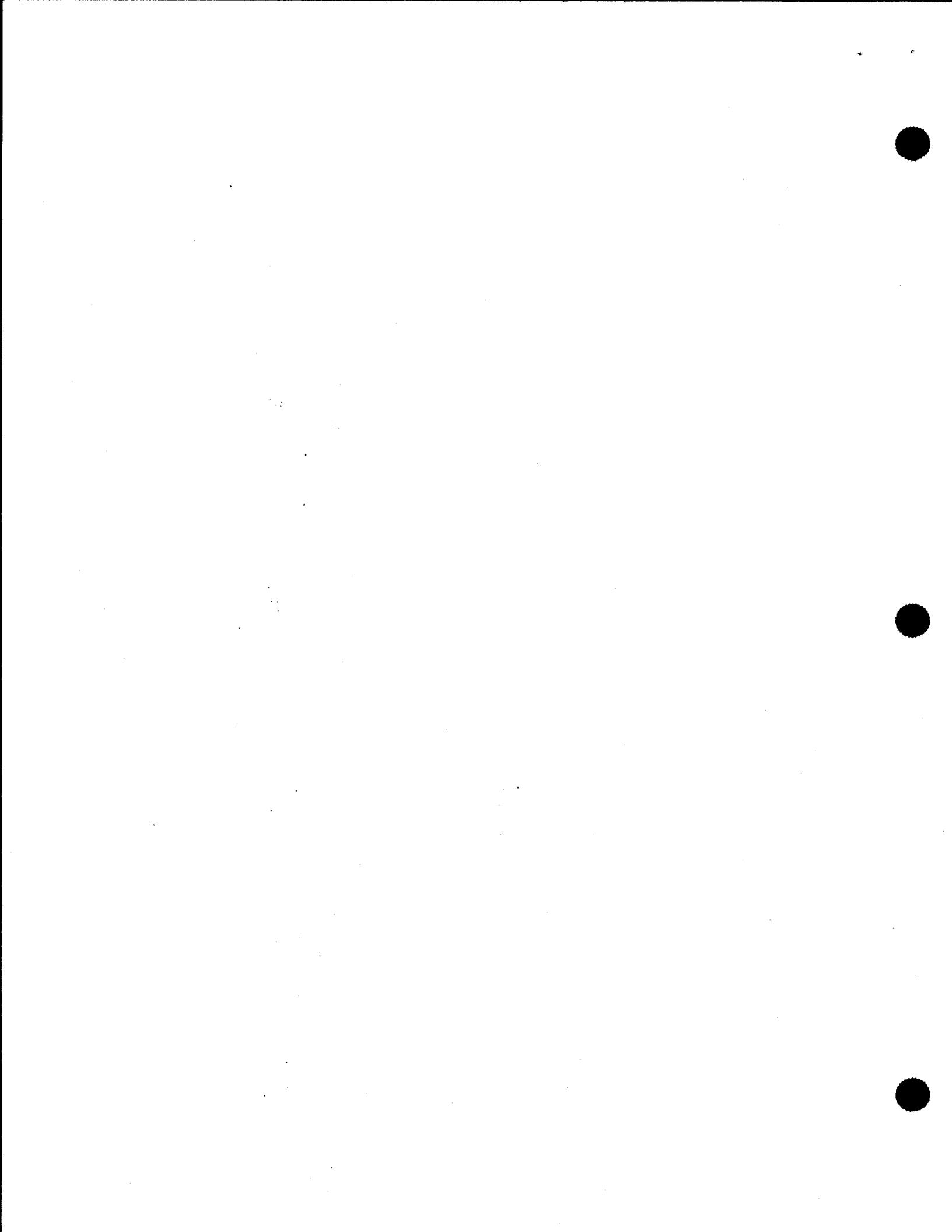



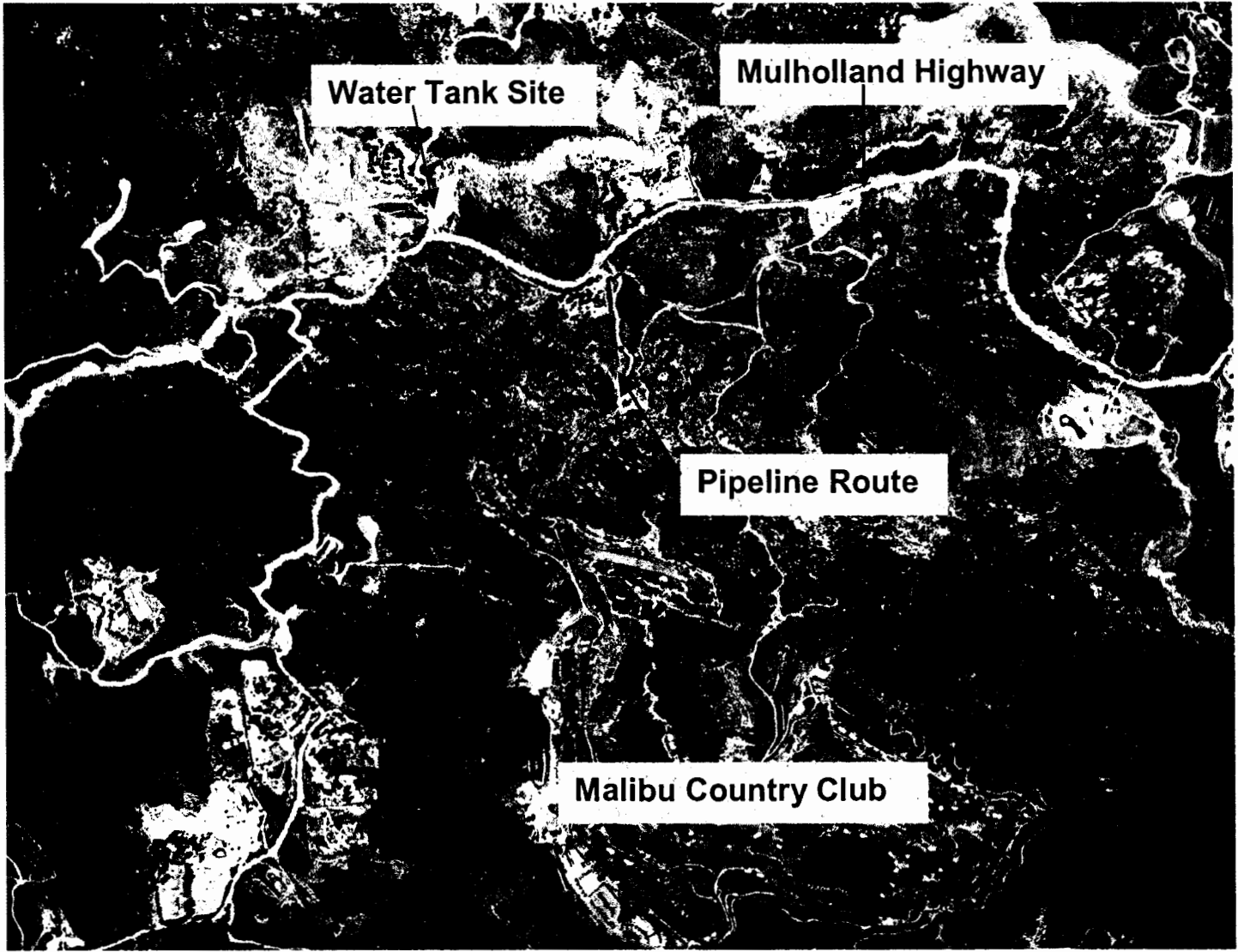
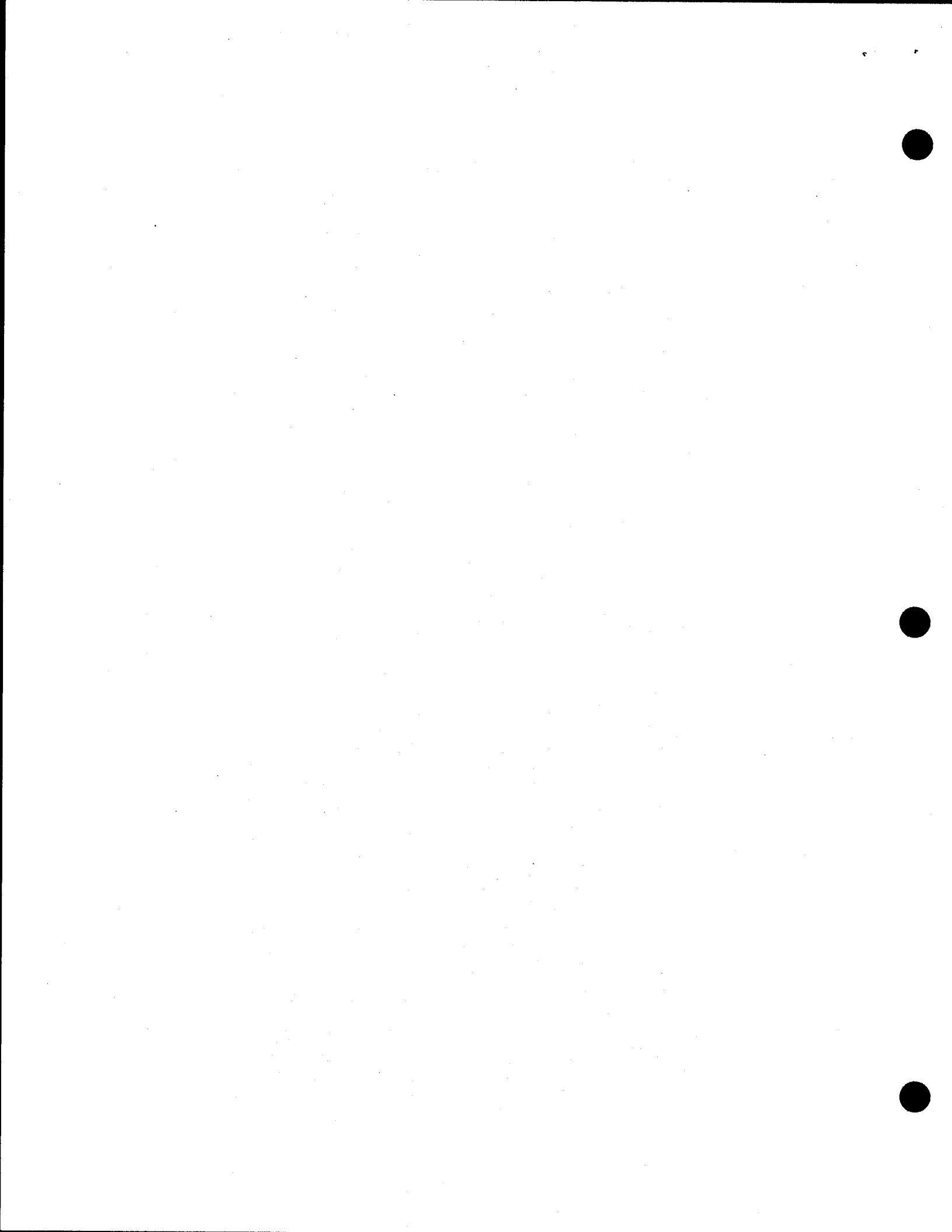

Exhibit 8
Permit 4-03-065
Aerial Photo

Aerial Photograph of the project sites and surrounding area, June 2001



Tank Site



Momentary view of the site from southwest of the site. The top of the proposed tank would be about at the end of the arrow.

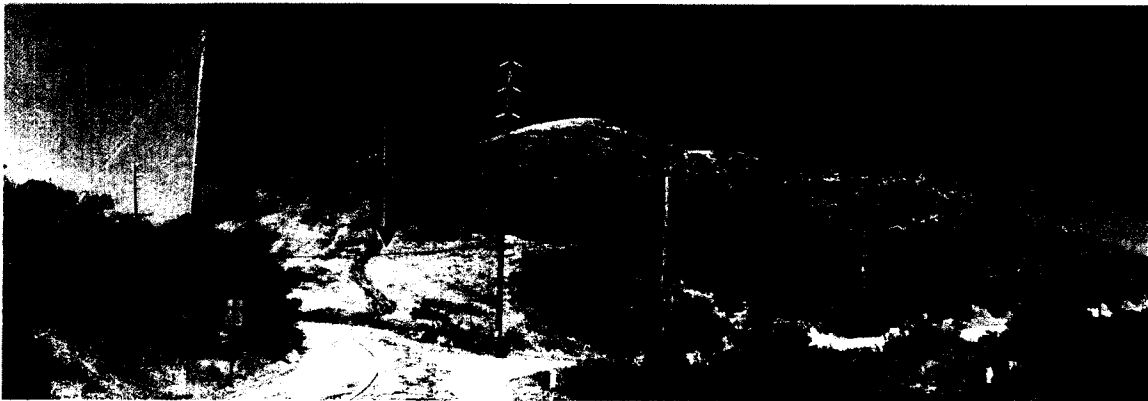

View from Westlake Boulevard, just south of the project site.  
Photos provided by Envicom Corporation.

Exhibit 9
Permit 4-03-065
Site Photos

