

CALIFORNIA COASTAL COMMISSION
South Coast Area Office
200 Oceangate, Suite 1000
Long Beach, CA 90802-4302
(562) 590-5071

Th5d



Staff: S. Vaughn – LB
Date: April 21, 2016

ADMINISTRATIVE PERMIT

Application No. **5-16-0107**

Applicant: **JCUBED Properties, LLC**

Agents: **Jacquelyn Chung, Swift Slip Dock & Pier Builders, Inc.**

Project Description: Remove 370 sq. ft. floating dock and pier platform and replace with a 296 sq. ft. floating dock and pier platform. Relocate two 12” marina guide piles.

Project Location: 419 East Edgewater Avenue, Newport Beach (Orange County)

EXECUTIVE DIRECTOR'S DETERMINATION

The findings for this determination, and for any special conditions, appear on subsequent pages.

NOTE: P.R.C. Section 30624 provides that this permit shall not become effective until it is reported to the Commission at its next meeting. If one-third or more of the appointed membership of the Commission so request, the application will be removed from the administrative calendar and set for public hearing at a subsequent Commission meeting. Our office will notify you if such removal occurs.

This permit will be reported to the Commission at the following time and place:

Thursday, May12, 2016, 9:00 a.m.
Newport Beach Civic Center, City Council Chambers
100 Civic Center Drive
Newport Beach, CA 92660

IMPORTANT - Before you may proceed with development, the following must occur:

Pursuant to 14 Cal. Admin. Code Sections 13150(b) and 13158, you must sign the enclosed duplicate copy acknowledging the permit's receipt and accepting its contents, including all conditions, and return it to our office. Following the Commission's meeting, and once we have received the signed acknowledgement and evidence of compliance with all special conditions, we will send you a Notice of Administrative Permit Effectiveness.

BEFORE YOU CAN OBTAIN ANY LOCAL PERMITS AND PROCEED WITH DEVELOPMENT, YOU MUST HAVE RECEIVED BOTH YOUR ADMINISTRATIVE PERMIT AND THE NOTICE OF PERMIT EFFECTIVENESS FROM THIS OFFICE.

JOHN AINSWORTH
Executive Director

By: Shannon Vaughn
Title: Coastal Program Analyst

STANDARD CONDITIONS:

This permit is granted subject to the following standard conditions:

1. **Notice of Receipt and Acknowledgment.** The permit is not valid and development shall not commence until a copy of the permit, signed by the permittee or authorized agent, acknowledging receipt of the permit and acceptance of the terms and conditions, is returned to the Commission office.
2. **Expiration.** If development has not commenced, the permit will expire two years from the date the Commission voted on the application. Development shall be pursued in a diligent manner and completed in a reasonable period of time. Application for extension of the permit must be made prior to the expiration date.
3. **Interpretation.** Any questions of intent or interpretation of any term or condition will be resolved by the Executive Director or the Commission.
4. **Assignment.** The permit may be assigned to any qualified person, provided assignee files with the Commission an affidavit accepting all terms and conditions of the permit.
5. **Terms and Conditions Run with the Land.** These terms and conditions shall be perpetual, and it is the intention of the Commission and the permittee to bind all future owners and possessors of the subject property to the terms and conditions.

SPECIAL CONDITIONS: See pages five through eight.

EXECUTIVE DIRECTOR'S DETERMINATION (continued):

The Executive Director hereby determines that the proposed development is a category of development, which, pursuant to PRC Section 30624, qualifies for approval by the Executive Director through the issuance of an Administrative Permit. Subject to Standard and Special Conditions as attached, said development is in conformity with the provisions of Chapter 3 of the Coastal Act of 1976 and will not have any significant impacts on the environment within the meaning of the California Environmental Quality Act. If located between the nearest public road and the sea, this development is in conformity with the public access and public recreation policies of Chapter 3.

FINDINGS FOR EXECUTIVE DIRECTOR'S DETERMINATION:

A. PROJECT DESCRIPTION

The applicant proposes to replace, reconfigure, and reduce water coverage and fill of an existing private residential floating dock system developed on tidelands seaward of an existing single-family residence (**Exhibit 2**). The existing floating dock system covers 370 sq. ft. of coastal waters and consists of a 20' x 8' finger, a 21' x 10' pier platform, nine marina guide piles, an approach, and a gangway. The applicant proposes to remove the 20' x 8' finger, the 21' x 10' pier platform, and one 14" square concrete "T" pile and install a new 35' x 5' finger, a new 10' x 10' pier platform, and to relocate (and reuse) two 12" square concrete marina guide piles. The approach and gangway are proposed to be kept in place and reused. The new dock system will result in 296 sq. ft. of coastal water coverage and will be comprised of composite material and wood. Water coverage from the proposed dock system will be decreased by 74 sq. ft. and fill will be reduced by 1.36 sq. ft. The project is located at 419 East Edgewater Avenue in the City of Newport Beach, Orange County and will not encroach bayward into Newport Bay. The proposed boat dock system meets the City of Newport Beach Harbor Permit Policy in that it will not extend past the U.S. Pierhead Line.

The proposed dock is being constructed on public tidelands and/or within an area subject to public trust doctrine. There is a public pedestrian bulkheaded walkway in between the applicant's property and the subject floating dock system. Seaward of the bulkheaded walkway is a small sandy beach, which may not always be exposed, especially during high tides. The small sandy beach is subject to the public trust; however, there is no direct public access to the small sandy beach due to the presence of the bulkhead. Direct access to the tidelands exists 0.20 miles northeast of the site at the end of Medina Way (**Exhibit 1**). From this access point, members of the public may access the beach/public tidelands and, for example, launch a kayak. At lower tides, it may be possible to walk under the residential piers for strolls down the sandy beach; however, this may be difficult because many of the piers do not appear to have enough clearance for a person to comfortably walk under. The applicant is not proposing to change the pier/approach at this time. Any future changes to the pier approach will require a coastal development permit. The public can also access the beach/public tidelands area seaward of the subject site by watercraft or by swimming to the site. In order to preserve and maintain access to the public tidelands, **Special Condition 4** is imposed stating that the approval of a Coastal Development Permit for the project does not waive any public rights or interest that exist or may exist on the property.

The dock project will be used for boating related purposes to serve a single-family residential development. On October 16, 2015, the site was surveyed by the City of Newport Beach Harbor Resources Division for eelgrass and *Caulerpa taxifolia* and neither was discovered within the project area. The eelgrass survey was completed during the active growth phase of eelgrass (typically March through October) and is valid for 60-days with the exception of surveys completed in August-October. *Caulerpa taxifolia* surveys are valid for 90 days. The project is agendized for the May 2016 Coastal Commission Hearing and the eelgrass and *Caulerpa taxifolia* surveys are no longer valid. Therefore, subsequent eelgrass and *Caulerpa taxifolia* surveys will be required prior to beginning any construction. As such, the Commission imposes **Special Conditions 2 and 3**, which identifies the procedures necessary to be completed prior to beginning any construction. Additionally, if *Caulerpa taxifolia* is found on the project site, **Special Condition 3** identifies the procedures necessary to be completed prior to beginning any construction.

The proposed project has received an approval in concept from the City of Newport Beach Harbor Resources Division (permit 112-419, November 9, 2015). The applicant submitted a permit application to the Regional Water Quality Control Board (RWQCB) on January 28, 2016, which went into proceed default on March 28, 2016. By default, the RWQCB has determined that the proposed project will not adversely impact water quality if standard construction methods and materials are used. Additionally, the applicant has applied for a permit from the U.S. Army Corps of Engineers (USACE). No negative comments have been received from the USACE and the permit is pending coastal development permit approval.

Section 30600(c) of the Coastal Act provides for the issuance of coastal development permits directly by the Commission in regions where the local government having jurisdiction does not have a certified Local Coastal Program. The City of Newport Beach only has a certified Land Use Plan and has not exercised the options provided in 30600(b) or 30600.5 to issue its own permits. Furthermore, the project is located seaward of the mean high tide line, where the Commission retains jurisdiction, even after certification of an LCP. Therefore, the Coastal Commission is the permit issuing entity and the standard of review is Chapter 3 of the Coastal Act. The certified Land Use Plan may be used for guidance.

B. MARINE RESOURCES

The proposed recreational boat dock development and its associated structures are an allowable and encouraged marine related use. The project design includes the minimum sized pilings and the minimum number of pilings necessary for structural stability. There are no feasible less environmentally damaging alternatives available. As conditioned, the project will not significantly adversely impact eelgrass beds and will not contribute to the dispersal of the invasive aquatic algae, *Caulerpa taxifolia*. Further, as conditioned, the project, which is to be used solely for recreational boating purposes, conforms to Sections 30224 and 30233 of the Coastal Act.

C. PUBLIC ACCESS

As conditioned, the proposed development will not have any new adverse impact on public access to the coast or to nearby recreational facilities. Thus, as conditioned, the proposed development conforms with Sections 30210 through 30214, Sections 30220 through 30224, and 30252 of the Coastal Act.

D. RECREATION

The proposed development, as conditioned, does not interfere with public recreational use of coastal resources. The proposed development, as conditioned, protects coastal areas suited for recreational activities. Therefore, the Commission finds that the proposed development, as conditioned, is in conformity with Sections 30210 through 30214 and Sections 30220 through 30223 of the Coastal Act regarding the promotion of public recreational opportunities.

E. WATER QUALITY

The proposed work will be occurring on, within, or adjacent to coastal waters. The storage or placement of construction material, debris, or waste in a location where it could be discharged into coastal waters would result in an adverse effect on the marine environment. To reduce the potential for construction related impacts on water quality, the Commission imposes special conditions

requiring, but not limited to, the appropriate storage and handling of construction equipment and materials to minimize the potential of pollutants to enter coastal waters. To reduce the potential for post-construction impacts to water quality the Commission requires the continued use and maintenance of post construction Best Management Practices. As conditioned, the Commission finds that the development conforms to Sections 30230 and 30231 of the Coastal Act.

F. LOCAL COASTAL PROGRAM

The LUP for the City of Newport Beach was effectively certified on May 19, 1982. The certified LUP was updated on October 8, 2009. As conditioned, the proposed development is consistent with Chapter 3 of the Coastal Act and with the certified Land Use Plan for the area. Approval of the project, as conditioned, will not prejudice the ability of the local government to prepare a Local Coastal Program that is in conformity with the provisions of Chapter 3.

G. CALIFORNIA ENVIRONMENTAL QUALITY ACT (CEQA)

As conditioned, there are no feasible alternatives or additional feasible mitigation measures available that would substantially lessen any significant adverse effect that the activity may have on the environment. Therefore, the Commission finds that the proposed project, as conditioned to mitigate the identified impacts, is the least environmentally damaging feasible alternative and can be found consistent with the requirements of the Coastal Act to conform to CEQA.

SPECIAL CONDITIONS:

This permit is granted subject to the following special conditions:

1. Water Quality

A. Construction Responsibilities and Debris Removal

- (1) No demolition or construction materials, equipment, debris, or waste shall be placed or stored where it may enter sensitive habitat, receiving waters or a storm drain, or be subject to wave, wind, rain or tidal erosion and dispersion;
- (2) Any and all debris resulting from demolition or construction activities, and any remaining construction material, shall be removed from the project site within 24 hours of completion of the project;
- (3) Demolition or construction debris and sediment shall be removed from work areas each day that demolition or construction occurs to prevent the accumulation of sediment and other debris that may be discharged into coastal waters;
- (4) Machinery or construction materials not essential for project improvements will not be allowed at any time in the intertidal zone;
- (5) If turbid conditions are generated during construction a silt curtain will be utilized to control turbidity;
- (6) Floating booms will be used to contain debris discharged into coastal waters and any debris discharged will be removed as soon as possible but no later than the end of each day;
- (7) Non buoyant debris discharged into coastal waters will be recovered by divers as soon as possible after loss;
- (8) All trash and debris shall be disposed in the proper trash and recycling receptacles at the end of every construction day;

Administrative Permit

- (9) The applicant shall provide adequate disposal facilities for solid waste, including excess concrete, produced during demolition or construction;
- (10) Debris shall be disposed of at a legal disposal site or recycled at a recycling facility. If the disposal site is located in the coastal zone, a coastal development permit or an amendment to this permit shall be required before disposal can take place unless the Executive Director determines that no amendment or new permit is legally required;
- (11) All stock piles and construction materials shall be covered, enclosed on all sides, shall be located as far away as possible from drain inlets and any waterway, and shall not be stored in contact with the soil;
- (12) Machinery and equipment shall be maintained and washed in confined areas specifically designed to control runoff. Thinners or solvents shall not be discharged into sanitary or storm sewer systems;
- (13) The discharge of any hazardous materials into any receiving waters shall be prohibited;
- (14) Spill prevention and control measures shall be implemented to ensure the proper handling and storage of petroleum products and other construction materials. Measures shall include a designated fueling and vehicle maintenance area with appropriate berms and protection to prevent any spillage of gasoline or related petroleum products or contact with runoff. The area shall be located as far away from the receiving waters and storm drain inlets as possible;
- (15) Best Management Practices (BMPs) and Good Housekeeping Practices (GHPs) designed to prevent spillage and/or runoff of demolition or construction-related materials, and to contain sediment or contaminants associated with demolition or construction activity, shall be implemented prior to the on-set of such activity; and
- (16) All BMPs shall be maintained in a functional condition throughout the duration of construction activity.

B. Best Management Practices Program

By acceptance of this permit the applicant agrees that the long-term water-borne berthing of boat(s) in the approved dock and/or boat slip will be managed in a manner that protects water quality pursuant to the implementation of the following BMPs:

- (1) Boat Cleaning and Maintenance Measures:
 - a. In-water top-side and bottom-side boat cleaning shall minimize the discharge of soaps, paints, and debris;
 - b. In-the-water hull scraping or any process that occurs under water that results in the removal of paint from boat hulls shall be prohibited. Only detergents and cleaning components that are designated by the manufacturer as phosphate-free and biodegradable shall be used, and the amounts used minimized; and
 - c. The applicant shall minimize the use of detergents and boat cleaning and maintenance products containing ammonia, sodium hypochlorite, chlorinated solvents, petroleum distillates or lye.
- (2) Solid and Liquid Waste Management Measures:
 - a. All trash, recyclables, and hazardous wastes or potential water contaminants, including old gasoline or gasoline with water, absorbent materials, oily rags,

lead acid batteries, anti-freeze, waste diesel, kerosene and mineral spirits will be disposed of in a proper manner and will not at any time be disposed of in the water or gutter.

(3) Petroleum Control Management Measures:

- a. Boaters will practice preventive engine maintenance and will use oil absorbents in the bilge and under the engine to prevent oil and fuel discharges. Oil absorbent materials shall be examined at least once a year and replaced as necessary. Used oil absorbents are hazardous waste in California. Used oil absorbents must therefore be disposed in accordance with hazardous waste disposal regulations. The boaters will regularly inspect and maintain engines, seals, gaskets, lines and hoses in order to prevent oil and fuel spills. The use of soaps that can be discharged by bilge pumps is prohibited;
- b. If the bilge needs more extensive cleaning (e.g., due to spills of engine fuels, lubricants or other liquid materials), the boaters will use a bilge pump-out facility or steam cleaning services that recover and properly dispose or recycle all contaminated liquids; and
- c. Bilge cleaners which contain detergents or emulsifiers will not be used for bilge cleaning since they may be discharged to surface waters by the bilge pumps.

2. Eelgrass Survey(s)

- A. Pre Construction Eelgrass Survey.** A valid pre-construction eelgrass (*Zostera marina*) survey shall be completed during the period of active growth of eelgrass (typically March through October). The pre-construction survey shall be completed prior to the beginning of construction and shall be valid until the next period of active growth. The survey shall be prepared in full compliance with the “Southern California Eelgrass Mitigation Policy” Revision 8 (except as modified by this special condition) adopted by the National Marine Fisheries Service and shall be prepared in consultation with the California Department of Fish and Game. The applicant shall submit the eelgrass survey for the review and approval of the Executive Director within five (5) business days of completion of each eelgrass survey and in any event no later than fifteen (15) business days prior to commencement of any development. If the eelgrass survey identifies any eelgrass within the project area which would be impacted by the proposed project, the development shall require an amendment to this permit from the Coastal Commission or a new coastal development permit.
- B. Post Construction Eelgrass Survey.** If any eelgrass is identified in the project area by the survey required in subsection A of this condition above, within one month after the conclusion of construction, the applicant shall survey the project site to determine if any eelgrass was adversely impacted. The survey shall be prepared in full compliance with the “Southern California Eelgrass Mitigation Policy” Revision 8 (except as modified by this special condition) adopted by the National Marine Fisheries Service and shall be prepared in consultation with the California Department of Fish and Game. The applicant shall submit the post-construction eelgrass survey for the review and approval of the Executive Director within thirty (30) days after completion of the survey. If any eelgrass has been impacted, the applicant shall replace the impacted eelgrass at a minimum 1.2:1 ratio on-

site, or at another location, in accordance with the Southern California Eelgrass Mitigation Policy. All impacts to eelgrass habitat shall be mitigated at a minimum ratio of 1.2:1 (mitigation: impact). The exceptions to the required 1.2:1 mitigation ratio found within SCEMP shall not apply. Implementation of mitigation shall require an amendment to this permit or a new coastal development permit unless the Executive Director determines that no amendment or new permit is required.

3. Pre-construction *Caulerpa Taxifolia* Survey

- A. Not earlier than 90 days nor later than 30 days prior to commencement or re-commencement of any development authorized under this coastal development permit (the “project”), the applicant shall undertake a survey of the project area and a buffer area at least 10 meters beyond the project area to determine the presence of the invasive alga *Caulerpa taxifolia*. The survey shall include a visual examination of the substrate.
- B. The survey protocol shall be prepared in consultation with the Regional Water Quality Control Board, the California Department of Fish and Game, and the National Marine Fisheries Service.
- C. Within five (5) business days of completion of the survey, the applicant shall submit the survey:
 - (1) for the review and approval of the Executive Director; and
 - (2) to the Surveillance Subcommittee of the Southern California Caulerpa Action Team (SCCAT). The SCCAT Surveillance Subcommittee may be contacted through William Paznokas, California Department of Fish & Game (858/467-4218) or Robert Hoffman, National Marine Fisheries Service (562/980-4043), or their successors.
- D. If *Caulerpa taxifolia* is found within the project or buffer areas, the applicant shall not proceed with the project until 1) the applicant provides evidence to the Executive Director that all *C. taxifolia* discovered within the project and buffer area has been eliminated in a manner that complies with all applicable governmental approval requirements, including but not limited to those of the California Coastal Act, or 2) the applicant has revised the project to avoid any contact with *C. taxifolia*. No revisions to the project shall occur without a Coastal Commission approved amendment to this coastal development permit unless the Executive Director determines that no amendment is legally required.

4. Public Rights

The Coastal Commission’s approval of this permit shall not constitute a waiver of any public rights that exist or may exist on the property. The permittee shall not use this permit as evidence of a waiver of any public rights that may exist on the property.

ACKNOWLEDGMENT OF PERMIT RECEIPT/ACCEPTANCE OF CONTENTS:

I/We acknowledge that I/we have received a copy of this permit and have accepted its contents including all conditions.

Applicant’s Signature

Date of Signing

Google Maps 419 Edgewater PI



Imagery ©2016 Google, Map data ©2016 Google 100 ft

Google Maps **COASTAL COMMISSION**
S-16-0107
 EXHIBIT # 1
 PAGE 1 OF 1

419 Edgewater Pl.
Balboa, CA.
Existing Dock

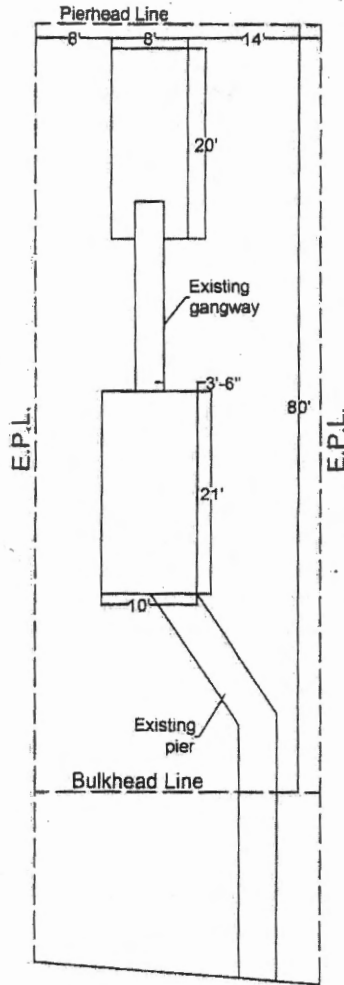

COASTAL COMMISSION

S-16-0107

EXHIBIT # 2

PAGE 1 OF 2



Swift Slip Dock & Pier Builders, Inc.

642 Baker St.
Costa Mesa, California 92626

Phone: (949) 631-3121
Fax: (714) 509-0618

Date	Revision	No.
10/28/15		

The information contained in this drawing is confidential and proprietary to Swift Slip Dock & Pier Builders, Inc. No part of this drawing may be distributed, disclosed or reproduced in any form to any third party without consent from Swift Slip Dock & Pier Builders, Inc.

419 Edgewater Pl. Balboa, CA. Proposed Dock

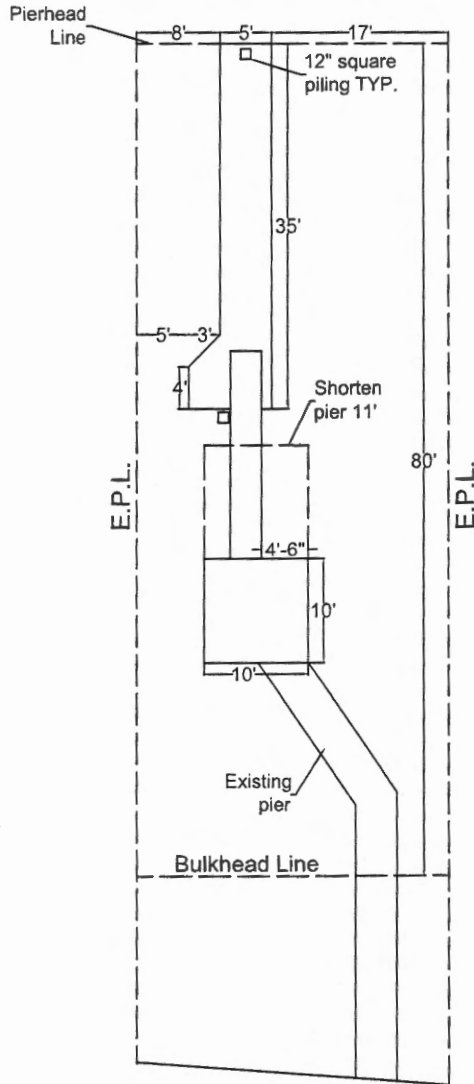

COASTAL COMMISSION

EXHIBIT # 2
PAGE 2 OF 2



Swift Slip Dock & Pier Builders, Inc.

642 Baker St.
Costa Mesa, California 92626

Phone: (949) 631-3121
Fax: (714) 509-0618

Date	Revision	No.
10/26/15		

The information contained in this drawing is confidential and proprietary to Swift Slip Dock & Pier Builders, Inc. No part of this drawing may be distributed, disclosed or reproduced in any form to any third party without consent from Swift Slip Dock & Pier Builders, Inc.