

CALIFORNIA COASTAL COMMISSION

South Coast Area Office
301 E. Ocean Blvd. Suite 300
Long Beach, CA 90802-4302
(562) 590-5071



W7a

5-21-0804 (SHERER)

MAY 11, 2022

EXHIBITS

Exhibit No. 1 – Location Map

Exhibit No. 2 – Project Plans



California Coastal Commission
CDP 5-21-0804
Exhibit 1

STRUCTURAL GENERAL NOTES

GENERAL REQUIREMENTS

- CONSTRUCTION SHALL BE IN CONFORMITY WITH THE 2019 EDITION OF THE CALIFORNIA BUILDING CODE (CBC) AND ALL APPLICABLE LOCAL AND STATE ORDINANCES.
- THE CONTRACTOR SHALL EXAMINE THE PROJECT SITE & SHALL VERIFY ALL DIMENSIONS, LOCATIONS & ELEVATIONS OF THE EXISTING CONSTRUCTION.
- CONTRACTOR SHALL CONSULT WITH REPRESENTATIVES OF CITY AND UTILITY AGENCIES TO VERIFY ALL UTILITIES BEFORE COMMENCING WORK, AND REPORT ANY PROBLEMS TO THE ENGINEER.
- CONTRACTOR SHALL FULLY PROTECT ALL ADJACENT PROPERTIES BEFORE COMMENCING ANY WORK.
- GENERAL NOTES ON DRAWINGS SHALL TAKE PRECEDENCE OVER THESE GENERAL REQUIREMENTS.
- TYPICAL DETAILS SHOWN SHALL APPLY WHERE NO SPECIAL DETAIL IS SHOWN.
- WRITTEN DIMENSIONS (NOT SCALED DIMENSIONS) SHALL BE USED.
- THE CONTRACTOR SHALL BE RESPONSIBLE FOR THE SAFETY OF THE CONSTRUCTION OF THIS PROJECT, INCLUDING SAFETY OF ALL PERSONS AND PROPERTY. THAT THIS REQUIREMENT SHALL APPLY CONTINUOUSLY AND NOT BE LIMITED TO THE CONSTRUCTION PERIOD. THE CONTRACTOR SHALL MAINTAIN DEFEND, INDEMNIFY AND HOLD THE OWNER AND THE ENGINEER HARMLESS FROM ANY AND ALL LIABILITY, REAL OR ALLEGED, IN CONNECTION WITH THE PERFORMANCE OF WORK ON THIS PROJECT, EXCEPTING FOR LIABILITY ARISING FROM NEGLIGENCE OR WILLFUL MISFEASANCE. THE CONTRACTOR SHALL BE RESPONSIBLE FOR THE SAFETY OF THE PROJECT SITE BY THE ENGINEER SHALL NOT BE CONSTRUED AS ANY INSPECTION AS REQUIRED BY CODE.

WOOD MEMBERS AND NAILING

- ALL ROUGH LUMBER USED IN THE WORK SHALL BE DOUGLAS FIR-LARCH NO. 1 OR BETTER, WITH THE BASE DESIGN VALUES COMPLYING WITH WESTERN WOOD PRODUCTS ASSOCIATION (WPA) DESIGN VALUES.
- ALL TIMBER SHALL BE MARKED WITH THE APPROPRIATE GRADE OF MATERIAL AND PRESERVATIVE TREATMENT, OR MAY BE SUBJECT TO REJECTION BY THE CITY INSPECTOR.
- ALL PRESERVATIVE FOR TIMBER:
 - ALL TIMBER PRODUCTS SHALL BE COATED WITH PRESERVATIVE TREATMENT TO RETENTION LIMITS RECOMMENDED BY THE AMERICAN WOOD PRESERVERS ASSOCIATION STANDARD M4 "STANDARD FOR THE CARE OF RESERVATIVE TREATED WOOD PRODUCTS" AND AWP/ STANDARD C2 "LUMBER, TIMBER, PRODUCTS & WINE TIES - PRESERVATIVE TREATMENT BY PRESSURE PROCESSES"
 - CURRENT STATE AND FEDERAL ENVIRONMENTAL REQUIREMENTS AND GUIDELINES FOR THE TYPE AND APPLICATION OF PRESERVATIVE TREATMENTS WILL BE STRICTLY ENFORCED.
 - ALL PRESERVATIVE TREATMENT SHALL BE VERIFIED BY THE AMERICAN PRESERVERS ASSOCIATION COMMITTEE FOR CONFORMANCE TO THE AMERICAN PRESERVERS ASSOCIATION STANDARDS.
 - FIELD CUTS AND BORED SHALL RECEIVE FIELD-APPLIED PRESERVATIVE TREATMENT IN ACCORDANCE WITH BEST MANAGEMENT PRACTICES. PRESERVATIVE TREATMENT CHEMICALS SHALL NOT BE ALLOWED TO ENTER HARBOR WATERS.
- ALL BOLT HOLES IN WOOD MEMBERS SHALL BE A MINIMUM OF $\frac{1}{8}$ " TO A MAXIMUM OF $\frac{1}{4}$ " LARGER THAN THE BOLT DIAMETER. WOOD MEMBERS WITH HOLES NOT MEETING THE ABOVE REQUIREMENTS SHALL BE REJECTED.
- ALL NAILS AND FASTENERS SHALL BE CORROSION RESISTANT MEETING ASTM A153 CLASS D, HOT DIP GALVANIZED AND BE ACRYLIC ADHESIVE OR THERMAL PLASTIC RESIN LATEX ADHESIVE COATED.
- ALL NAILS SHALL BE 20d (0.192" DIAMETER) HELICAL THREAD NAILS, WITH MINIMUM BENDING YIELD STRENGTH OF $F_y = 90,000$ PSI, U.N.O.

STEEL

- STRUCTURAL STEEL SHAPES AND PLATES SHALL CONFORM TO A.S.T.M. A572 GRADE 50 OR A992 WITH $F_y = 50$ KSI.
- BOLTS SHALL CONFORM TO A.S.T.M. A307, UNLESS NOTED OTHERWISE.
- ALL BOLTS HOLES IN STEEL MEMBERS SHALL BE STANDARD HOLES, U.N.O.
- ALL SPECIFICATIONS SHALL CONFORM TO THE LATEST EDITION OF THE AISC SPECIFICATIONS.
- ALL HOLES FOR BOLTS IN STRUCTURAL STEEL SHALL BE DRILLED OR PUNCHED. BURNING OF HOLES SHALL NOT BE PERMITTED.
- ALL STEEL SHALL BE STAINLESS, HOT DIP GALVANIZED OR EPOXY COATED.

WELDING

- ALL WELDING SHALL BE DONE USING THE SHIELDED ELECTRIC ARC PROCESS BY A LICENSED WELDER.
- SPECIAL INSPECTION IS REQUIRED FOR ALL FIELD WELDING.

CONCRETE

- ALL CONCRETE MIX DESIGNS, CONFORMING TO CHAPTER 19 OF A.C.I. 318-14, TABLE 19.2.3.2, SHALL BE SUBMITTED TO THE ENGINEER FOR REVIEW AND APPROVAL BEFORE ANY CONCRETE IS PLACED. ALL CONCRETE MIXES SHALL HAVE A MINIMUM CEMENT CONTENT OF 6.0 BAGS OF CEMENT PER CUBIC YARD OF MIX. ALL CONCRETE MIXES SHALL BE REGISTERED CIVIL ENGINEER TESTING LABORATORY AND SIGNED BY A CALIFORNIA REGISTERED CIVIL ENGINEER.
- CONCRETE SHALL HAVE MINIMUM 28 DAY COMPRESSIVE STRENGTH OF 4500 PSI AND A 0.40 WATER-TO-CEMENT RATIO. BE TAKEN IN ACCORDANCE WITH A.S.T.M. AND CBC STANDARDS. RESULTS OF THE 7 & 28 DAY TESTS SHALL BE SUBMITTED TO THE ENGINEER FOR HIS RECORDS. SLUMP TESTS ARE REQUIRED FOR ALL TEST SAMPLES AND MUST ALSO BE REPORTED.
- FORMWORK SHALL BE DESIGNED TO SUPPORT ALL LOADS AND SHALL BE IN ACCORDANCE WITH CBC AND A.C.I. STANDARDS.
- ALL STEEL REINFORCING, ANCHOR BOLTS, DOWELS AND OTHER INSERTS SHALL BE SECURED IN POSITION AND INSPECTED BY THE LOCAL BUILDING DEPARTMENT INSPECTOR, PRIOR TO THE PLACING OF ANY CONCRETE.

REINFORCING STEEL

- ALL REINFORCING STEEL, UNLESS NOTED OTHERWISE, SHALL CONFORM TO A.S.T.M. A618 GRADE 60 FOR BARS #4 AND GREATER, AND GRADE 40 FOR BARS LESS THAN #4 AND ALL TIES AND DOWELS.
- ALL REINFORCEMENT TO BE WELDED SHALL CONFORM TO A.S.T.M. A706, UNLESS NOTED OTHERWISE.
- REINFORCEMENT MARKED CONTINUOUS MAY BE SPliced BY LAPPING 42 BAR DIAMETERS OR MORE. ALL REINFORCEMENT SHALL BE WELDED WITH 4:1 INCH MINIMUM LAP IN EACH CASE, UNLESS NOTED OTHERWISE ON PLANS. ALL SPICES WHEN DETAILED SHALL BE LOCATED WHERE SHOWN ON PLANS.
- REINFORCING STEEL SHALL BE ACCURATELY PLACED AND SECURED IN POSITION WITH METAL OR CONCRETE BLOCKS, CHAIRS, SPACERS, ETC., AND WIRE TIES BEFORE PLACING ANY CONCRETE. ON GRADE SHALL CONFORM TO A.S.T.M. A706. ALL REINFORCEMENT SHALL BE WELDED TOGETHER AND HAVE A MINIMUM LAP OF ONE PARALLEL STRAND BUT NOT LESS THAN 6".
- REINFORCEMENT DETAILING SHALL BE IN ACCORDANCE WITH CBC SECTION 1907.
- ALL TIE WIRES SHALL BE MINIMUM 16 GAUGE, BLACK ANNEALED, CONFORMING TO A.S.T.M. A82.
- ALL REINFORCING BARS SHALL BE FREE OF RUST, GREASE OR OTHER MATERIAL WHICH COULD AFFECT THE BONDING.
- ALL BENDS IN REINFORCING SHALL BE COLD BENDS.

ABBREVIATIONS

A.B.	ANCHOR BOLT	EA	EXISTING	FF	FINISH FLOOR	HT	HEIGHT
ADDL	ADDITIONAL	ELEC	ELECTRICAL	FN	FIELD NAILING	HGR	HANGER
ATR	ALL THREADED ROD	ELEV	ELEVATION	F.S.	FAR SIDE	HORIZ	HORIZONTAL
BET	BETWEEN	EMBED	EMBEDMENT	GA	GAUGE	HT	HEIGHT
BLKG	BLOCKING	EQUA	EQUAL	GALV	GALVANIZED	IN	INCH
BM	BEAM	E.W.	EACH WAY	GA	GAUGE	INFO	INFORMATION
CLR	CLEAR	EXIST	EXISTING	LG	LONG	L	LONG
CONC	CONCRETE	EA	EACH	LG	LONG	LLH	LONG LEG HORIZONTAL
CONT	CONTINUOUS	EACH FACE	EACH FACE	LLV	LONG LEG VERTICAL		
CTR	CENTER	ELECTRICAL	ELECTRICAL				
DBL	DOUBLE	ELEVATION	ELEVATION				
DET	DETAIL	EQUA	EQUAL				
DIAG	DIAGONAL	E.W.	EACH WAY				
DIA	DIAMETER	EXIST	EXISTING				
DIA	DIAMETER	FF	FINISH FLOOR				
DF	DEEP	FN	FIELD NAILING				
DWS	DRAWINGS	F.S.	FAR SIDE				
(E)	EXISTING	GALV	GALVANIZED				
EA	EACH	GA	GAUGE				
E.F.	EACH FACE	HGR	HANGER				
ELEC	ELECTRICAL	HORIZ	HORIZONTAL				
ELEV	ELEVATION	HT	HEIGHT				
EMBED	EMBEDMENT	IN	INCH				
EQUA	EQUAL	INFO	INFORMATION				
E.W.	EACH WAY	L	LONG				
EXIST	EXISTING	LLH	LONG LEG HORIZONTAL				
FF	FINISH FLOOR	LLV	LONG LEG VERTICAL				
FN	FIELD NAILING						
F.S.	FAR SIDE						
GALV	GALVANIZED						
GA	GAUGE						
HGR	HANGER						
HORIZ	HORIZONTAL						
HT	HEIGHT						
IN	INCH						
INFO	INFORMATION						
L	LONG						
LLH	LONG LEG HORIZONTAL						
LLV	LONG LEG VERTICAL						

MAX	MAXIMUM	SCH	SCHEDULE	T & B	TOP & BOTTOM	VERT	VERTICAL
M.B.	METAL BOLT	SECT	SECTION	THK	THICK	V.I.F.	VERIFY IN FIELD
M.F.O.	METAL FRAMED OPENING	SHT	SHEET	THRU	THROUGH	W/	WITH
MIN	MINIMUM	SIM	SIMILAR	TOT	TOTAL	WO	WOOD
MISC	MISCELLANEOUS	STAGG	STAGGERED	TOT	TOTAL	W/O	WITHOUT
MTL	METAL	STD	STANDARD	TYP	TYPICAL	WT	WEIGHT
(N)	NEW	STIFF	STIFFENER	U.N.O.	UNLESS NOTED OTHERWISE		
NO	NUMBER	STL	STEEL				
N.S.	NEAR SIDE	STRUCT	STRUCTURAL				
N.T.S.	NOT TO SCALE	STM	STRUCTURAL				
O.C.	ON CENTER	STM	STRUCTURAL				
OPB	OPPOSITE HAND	T & B	TOP & BOTTOM				
OPF	OPPOSITE FACE	THK	THICK				
OPF HD	OPPOSITE HAND	THRU	THROUGH				
PEN	PENETRATION	TOT	TOTAL				
PL	PLATE OR PROPERTY LINE	TYP	TYPICAL				
PL	PLATE OR PROPERTY LINE	U.N.O.	UNLESS NOTED OTHERWISE				
PSI	POUNDS PER SQUARE INCH						
P-T	PRESERVATIVE TREATED WOOD						
REBAR	REINFORCING BAR						
REF	REFERENCE						
REIN	REINFORCING						
REQD	REQUIRED						
REV	REVISION						

MAX	MAXIMUM
M.B.	METAL BOLT
M.F.O.	METAL FRAMED OPENING
MIN	MINIMUM
MISC	MISCELLANEOUS
MTL	METAL
(N)	NEW
NO	NUMBER
N.S.	NEAR SIDE
N.T.S.	NOT TO SCALE
O.C.	ON CENTER
OPB	OPPOSITE HAND
OPF	OPPOSITE FACE
OPF HD	OPPOSITE HAND
PEN	PENETRATION
PL	PLATE OR PROPERTY LINE
PSI	POUNDS PER SQUARE INCH
P-T	PRESERVATIVE TREATED WOOD
REBAR	REINFORCING BAR
REF	REFERENCE
REIN	REINFORCING
REQD	REQUIRED
REV	REVISION

A.B.	ANCHOR BOLT
ADDL	ADDITIONAL
ATR	ALL THREADED ROD
BET	BETWEEN
BLKG	BLOCKING
BM	BEAM
CLR	CLEAR
CONC	CONCRETE
CONT	CONTINUOUS
CTR	CENTER
DBL	DOUBLE
DET	DETAIL
DIAG	DIAGONAL
DIA	DIAMETER
DIA	DIAMETER
DF	DEEP
DWS	DRAWINGS
(E)	EXISTING
EA	EACH
E.F.	EACH FACE
ELEC	ELECTRICAL
ELEV	ELEVATION
EMBED	EMBEDMENT
EQUA	EQUAL
E.W.	EACH WAY
EXIST	EXISTING
FF	FINISH FLOOR
FN	FIELD NAILING
F.S.	FAR SIDE
GALV	GALVANIZED
GA	GAUGE
HGR	HANGER
HORIZ	HORIZONTAL
HT	HEIGHT
IN	INCH
INFO	INFORMATION
L	LONG
LLH	LONG LEG HORIZONTAL
LLV	LONG LEG VERTICAL

OWNER / APPLICANT
JOHN ROCKY SHERER
3311 ADMIRALTY DRIVE
HUNTINGTON BEACH, CA 92649

REPLACING THE EXISTING FLOATING DOCK & GANGWAY LOCATED AT:
3311 ADMIRALTY DRIVE
HUNTINGTON BEACH, CA 92649
 STRUCTURAL GENERAL NOTES

WILLIAM SIMPSON & ASSOCIATES, INC.
 CONSULTING STRUCTURAL ENGINEERS
 23 ORCHARD, SUITE 250
 LAKE FOREST, CA 92650
 F (949) 206-9925
 P (949) 206-9925
 WWS@WWS&A.COM
 WWW.WWS&A.COM



DATE: 11/29/21
 PROJECT: A. HEKMAT
 DRAWN BY: M. JAFARI
 CHECKED BY: W. LAMNICKAZK
 DESIGNED BY: W. LAMNICKAZK
 11/29/21

7690
 S-1

ISSUANCE OF A BUILDING PERMIT BY THE CITY OF DOES NOT RELIEVE APPLICANTS OF THE LEGAL REQUIREMENTS TO OBSERVE COVENANTS, CONDITIONS AND RESTRICTIONS WHICH MAY BE APPLICABLE TO THE PROPERTY. YOU SHOULD OBTAIN PLANS. YOU SHOULD CONTACT YOUR COMMUNITY ASSOCIATION PRIOR TO COMMENCING CONSTRUCTION AUTHORIZED BY THIS PERMIT.

PRIOR TO PERFORMING ANY WORK IN THE CITY RIGHT-OF-WAY AN ENCROACHMENT PERMIT MUST BE OBTAINED FROM THE PUBLIC WORKS DEPARTMENT.

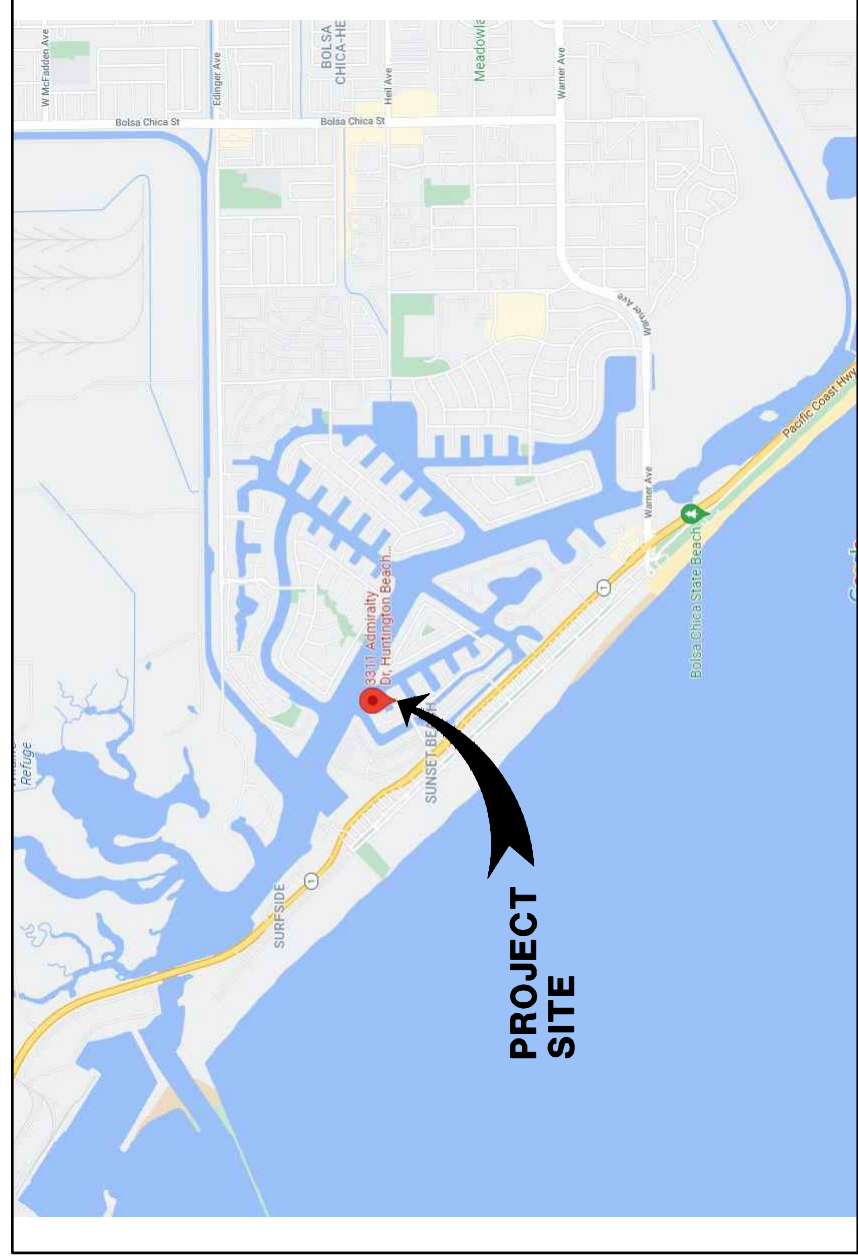

VICINITY MAP

SCOPE OF WORK:

- TO REMOVE AND REPLACE THE EXISTING FLOATING DOCK & GANGWAY WITH A NEW FLOATING DOCK & GANGWAY LIKE FOR LIKE AS REFLECTED ON SHEET S-2.

OWNER / APPLICANT
JOHN ROCKY SHERER
3311 ADMIRALTY DRIVE
HUNTINGTON BEACH, CA 92649

REPLACING THE EXISTING FLOATING DOCK & GANGWAY LOCATED AT:
HUNTINGTON BEACH, CA 92649

REPLACING THE EXISTING FLOATING DOCK PLANS

WILLIAM SIMPSON & ASSOCIATES, INC.
 CONSULTING STRUCTURAL ENGINEERS
 23 ORCHARD, SUITE 250
 LAKE FOREST, CA 92650
 WWW.WS05E.COM
 F (949) 206-9955
 F (949) 206-9929
 wsj@ws05e.com



DATE	11/29/21
DES.	A. HEKMAT
DRAWN	M. FARAG
CHECKED	M. JAFARI
PROJ. MGR.	A. HEKMAT

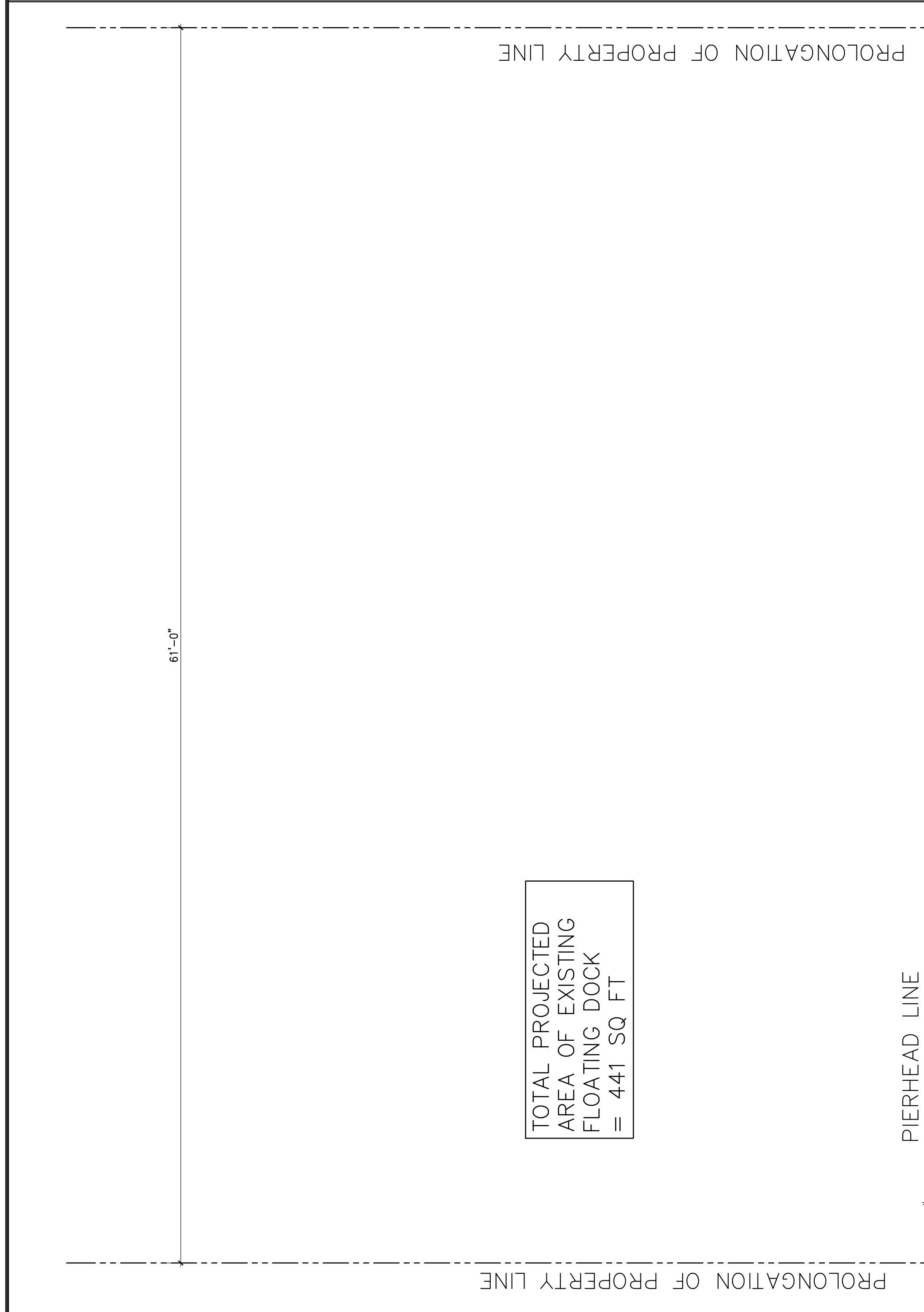

TOTAL PROJECTED AREA OF EXISTING FLOATING DOCK = 441 SQ FT

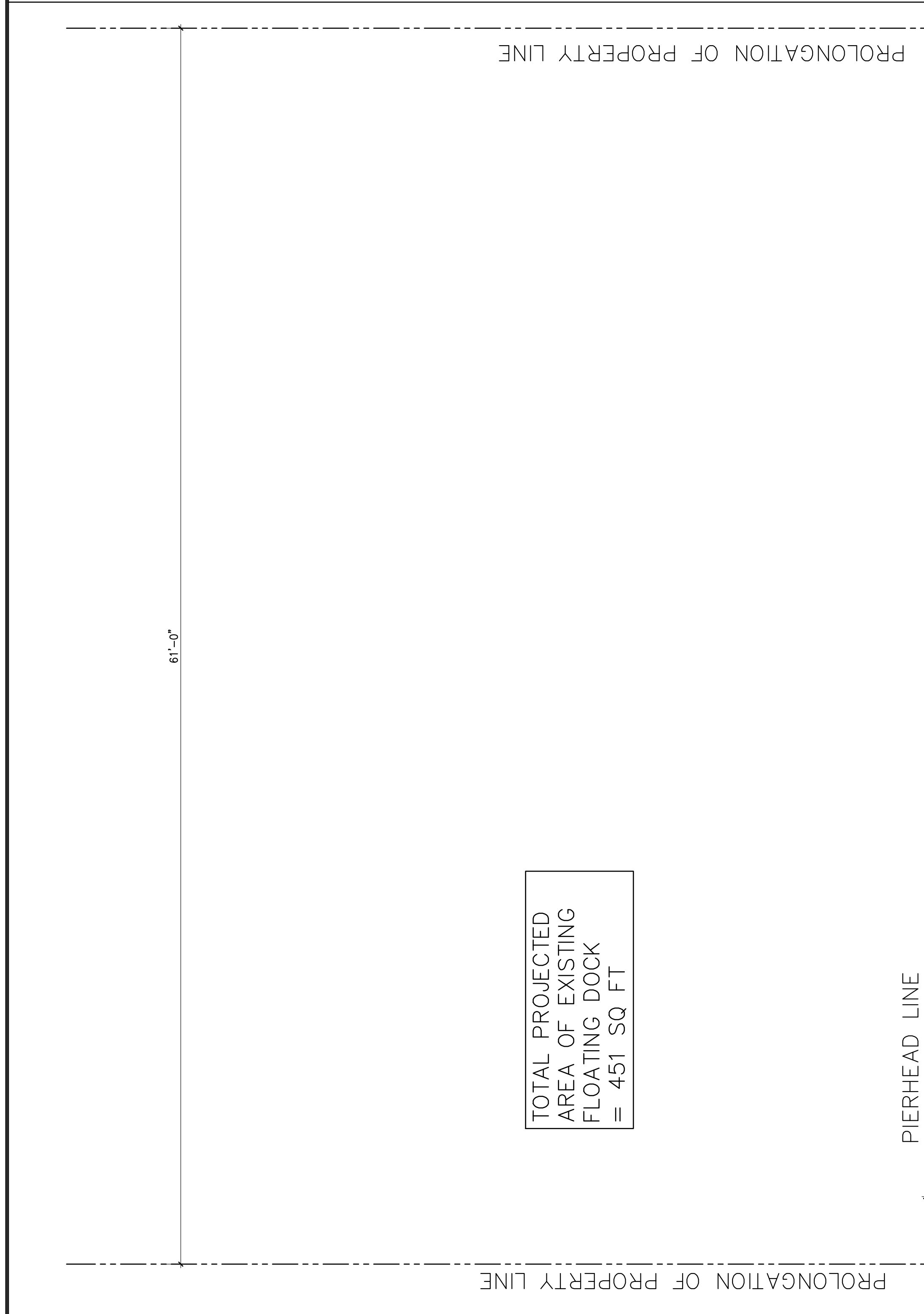

TOTAL PROJECTED AREA OF EXISTING FLOATING DOCK = 451 SQ FT

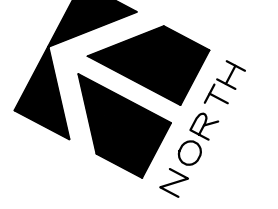

V N.T.S. PROPOSED DOCK, PILING AND GANGWAY LAYOUT T N.T.S. EXISTING DOCK, PILING AND GANGWAY LAYOUT

FLOAT DRUM SCHEDULE			
FLOAT DRUM TYPE	WIDTH	LENGTH	DEPTH
(1)	95"	195"	32"

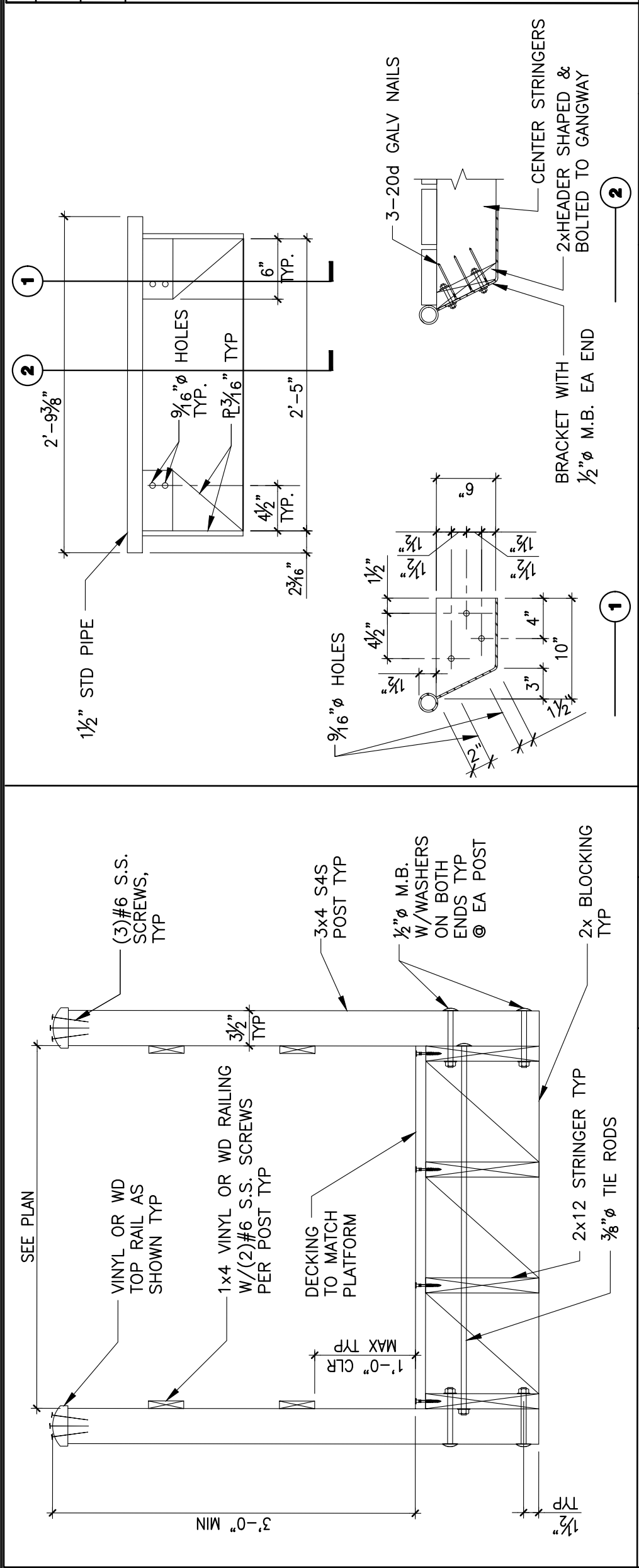

GANGWAY SECTION N.T.S.

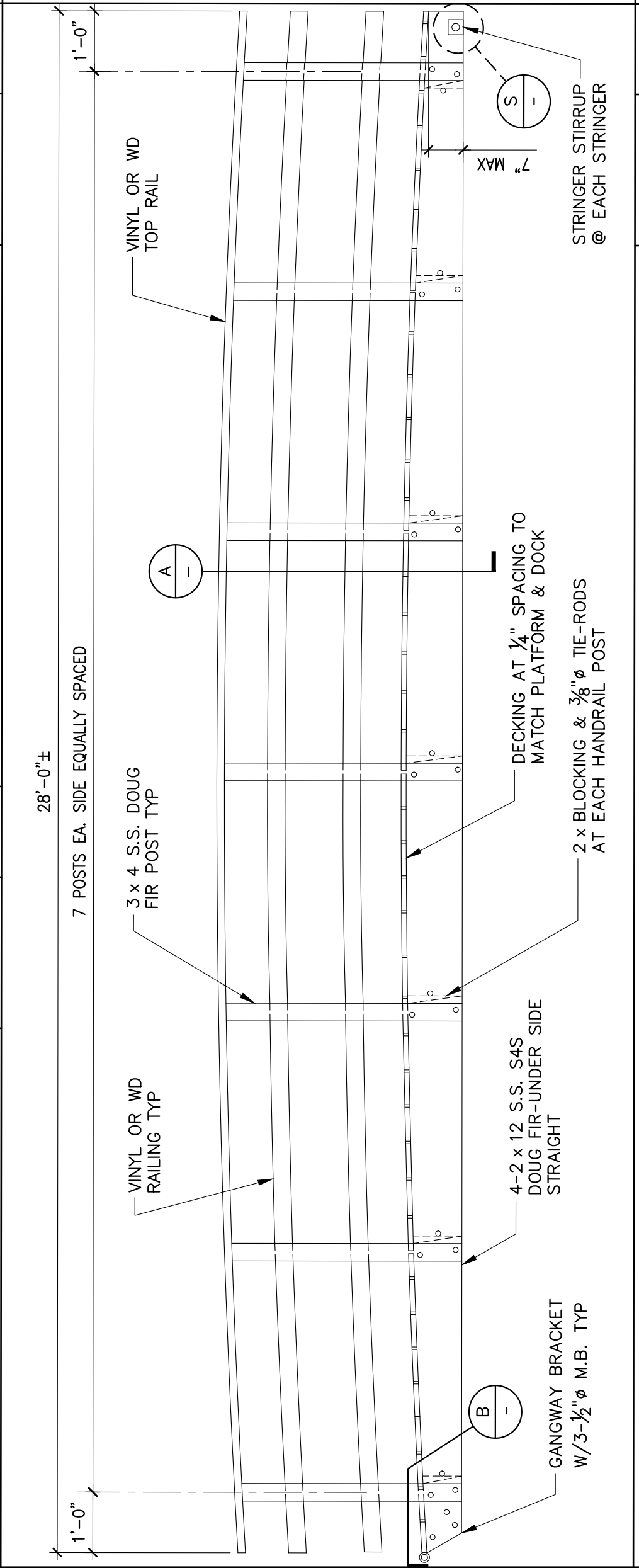

GANGWAY BRACKET N.T.S.

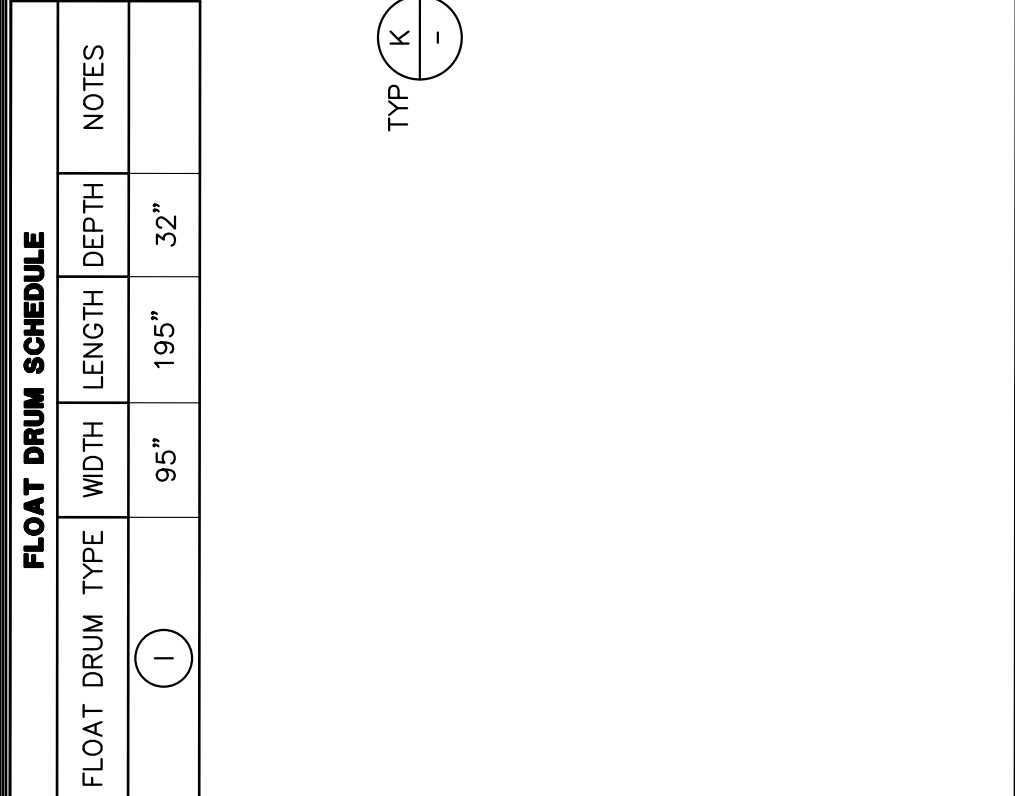

GANGWAY ELEVATION N.T.S.



GANGWAY HANGER - SIDE N.T.S.

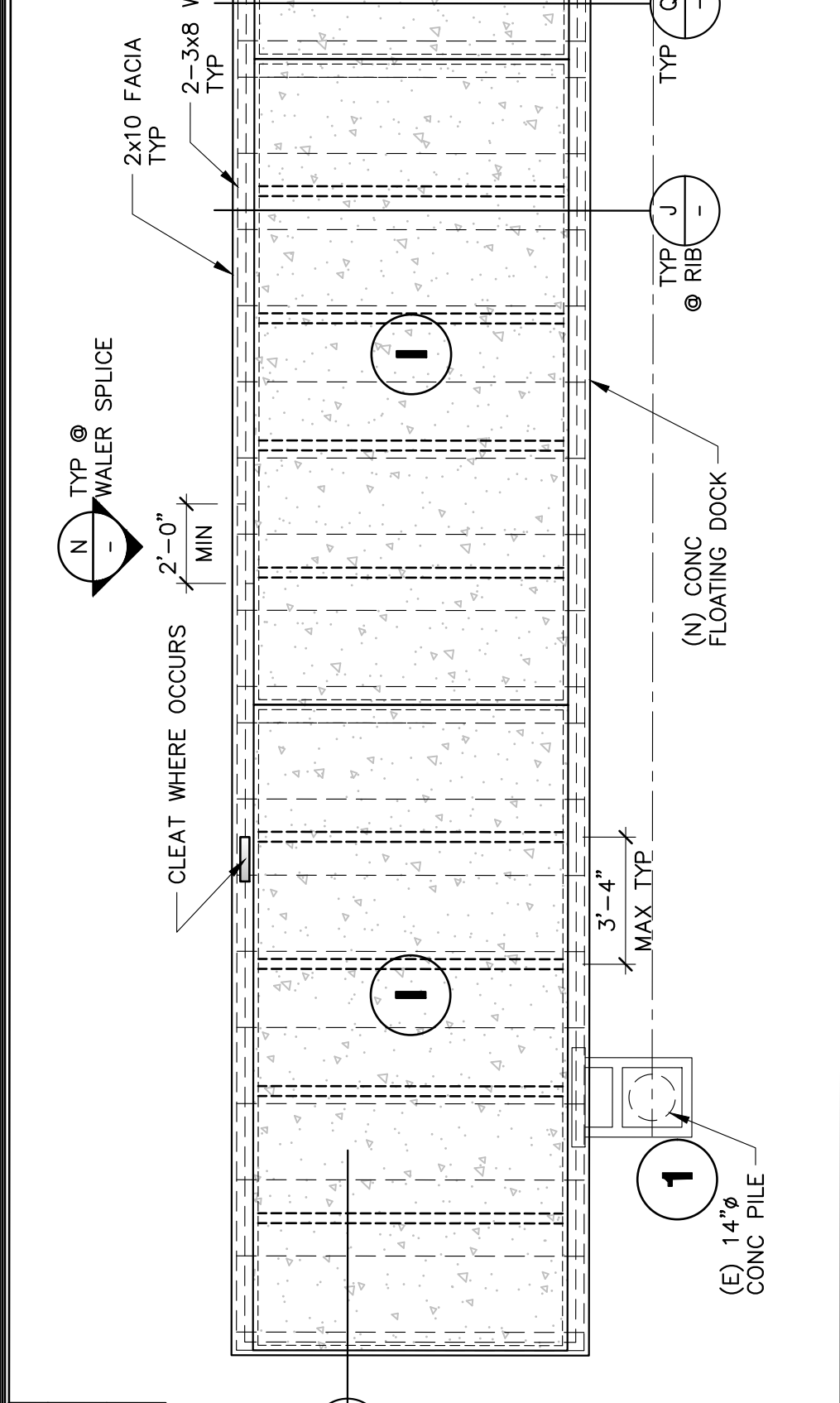

GANGWAY HANGER - TOP N.T.S.

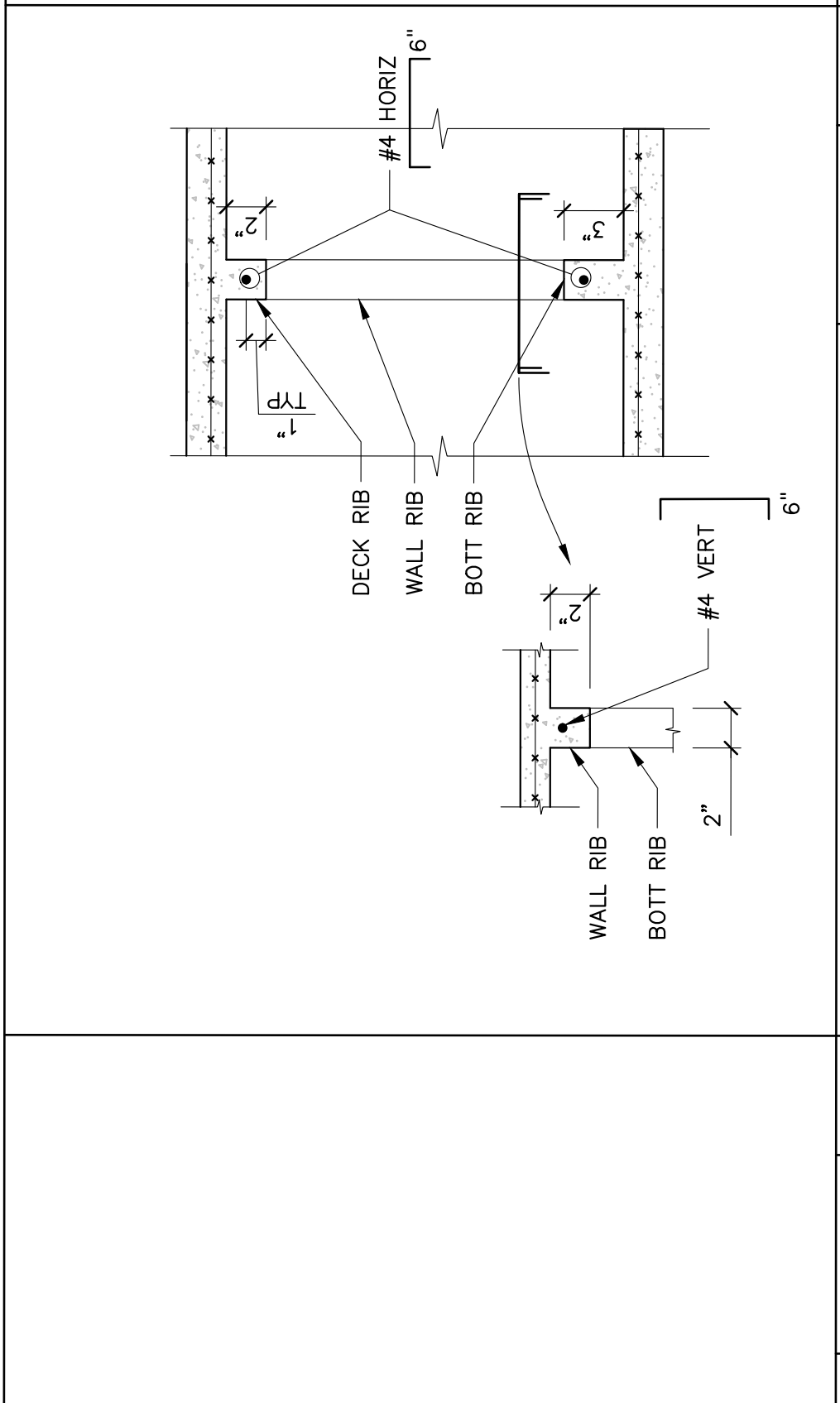

WALER SPlice DETAIL N.T.S.

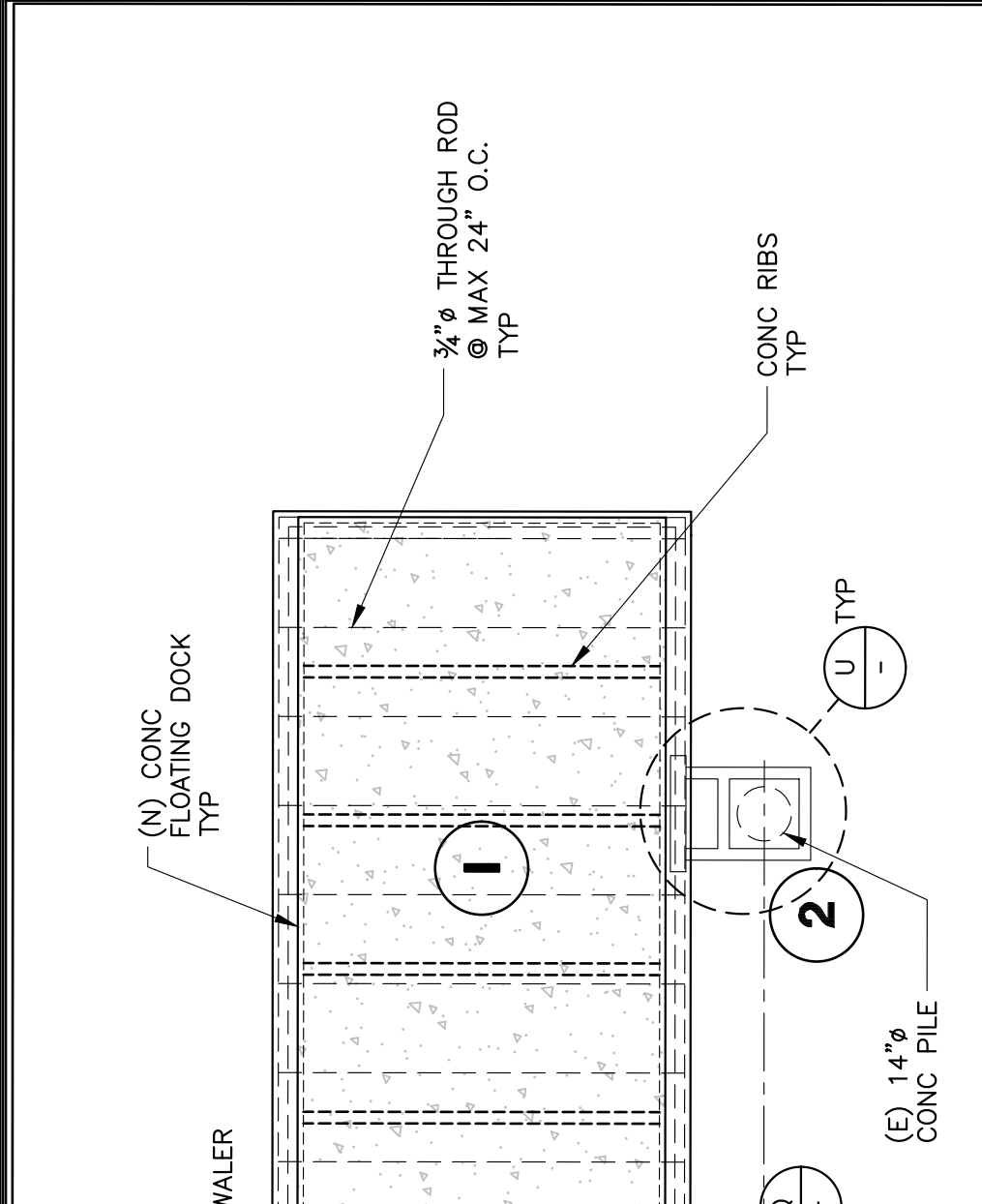

PILE GUIDES DETAIL N.T.S.

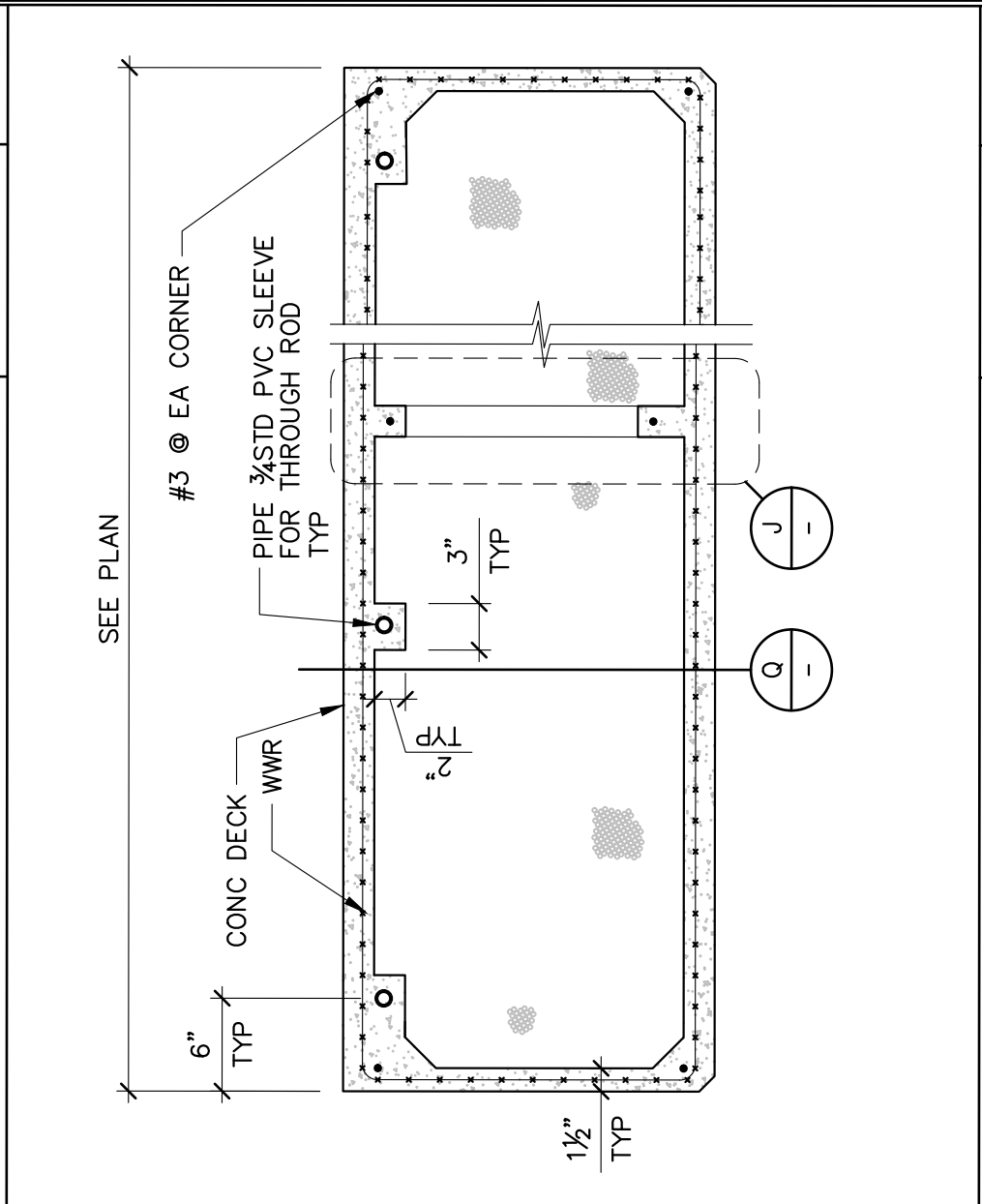

REINFORCING RIBS N.T.S.

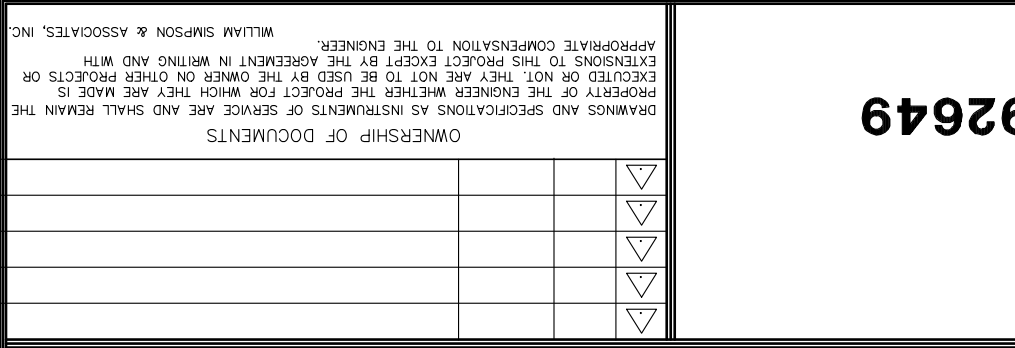

LONGITUDINAL SECTION N.T.S.

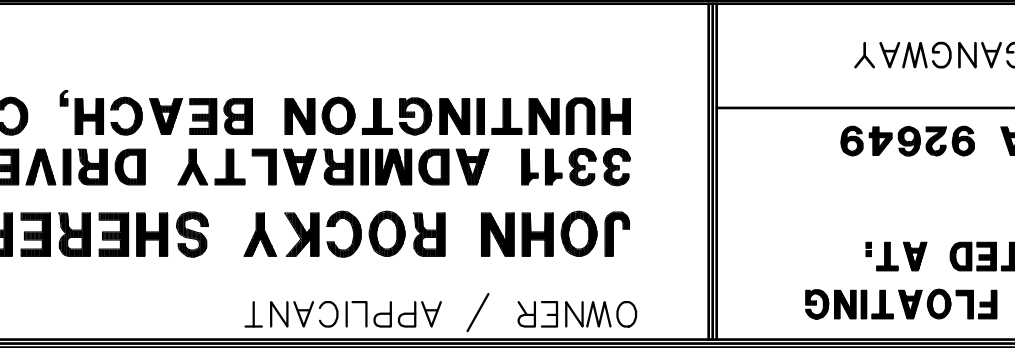

FLOAT SECTION N.T.S.

CLEAT DETAIL N.T.S.

CLEAT DETAIL N.T.S.

CLEAT DETAIL N.T.S.

CLEAT DETAIL N.T.S.

CLEAT DETAIL N.T.S.

CLEAT DETAIL N.T.S.

CLEAT DETAIL N.T.S.

CLEAT DETAIL N.T.S.

CLEAT DETAIL N.T.S.

CLEAT DETAIL N.T.S.

CLEAT DETAIL N.T.S.

CLEAT DETAIL N.T.S.

CLEAT DETAIL N.T.S.

CLEAT DETAIL N.T.S.

CLEAT DETAIL N.T.S.

CLEAT DETAIL N.T.S.

CLEAT DETAIL N.T.S.

CLEAT DETAIL N.T.S.

CLEAT DETAIL N.T.S.

CLEAT DETAIL N.T.S.

CLEAT DETAIL N.T.S.

CLEAT DETAIL N.T.S.

CLEAT DETAIL N.T.S.

CLEAT DETAIL N.T.S.

CLEAT DETAIL N.T.S.

CLEAT DETAIL N.T.S.

CLEAT DETAIL N.T.S.

CLEAT DETAIL N.T.S.

CLEAT DETAIL N.T.S.

CLEAT DETAIL N.T.S.

CLEAT DETAIL N.T.S.

CLEAT DETAIL N.T.S.

CLEAT DETAIL N.T.S.

CLEAT DETAIL N.T.S.

CLEAT DETAIL N.T.S.

CLEAT DETAIL N.T.S.

CLEAT DETAIL N.T.S.

CLEAT DETAIL N.T.S.

CLEAT DETAIL N.T.S.

CLEAT DETAIL N.T.S.

CLEAT DETAIL N.T.S.

CLEAT DETAIL N.T.S.

CLEAT DETAIL N.T.S.

CLEAT DETAIL N.T.S.

CLEAT DETAIL N.T.S.

CLEAT DETAIL N.T.S.

CLEAT DETAIL N.T.S.

CLEAT DETAIL N.T.S.

CLEAT DETAIL N.T.S.

CLEAT DETAIL N.T.S.

CLEAT DETAIL N.T.S.

CLEAT DETAIL N.T.S.

CLEAT DETAIL N.T.S.

CLEAT DETAIL N.T.S.

CLEAT DETAIL N.T.S.

CLEAT DETAIL N.T.S.

CLEAT DETAIL N.T.S.

CLEAT DETAIL N.T.S.

CLEAT DETAIL N.T.S.

CLEAT DETAIL N.T.S.

CLEAT DETAIL N.T.S.

CLEAT DETAIL N.T.S.

CLEAT DETAIL N.T.S.

CLEAT DETAIL N.T.S.

CLEAT DETAIL N.T.S.

CLEAT DETAIL N.T.S.

CLEAT DETAIL N.T.S.

CLEAT DETAIL N.T.S.

CLEAT DETAIL N.T.S.

CLEAT DETAIL N.T.S.

CLEAT DETAIL N.T.S.

CLEAT DETAIL N.T.S.

CLEAT DETAIL N.T.S.

CLEAT DETAIL N.T.S.

CLEAT DETAIL N.T.S.

CLEAT DETAIL N.T.S.

CLEAT DETAIL N.T.S.

CLEAT DETAIL N.T.S.

CLEAT DETAIL N.T.S.

CLEAT DETAIL N.T.S.

CLEAT DETAIL N.T.S.

CLEAT DETAIL N.T.S.

CLEAT DETAIL N.T.S.

CLEAT DETAIL N.T.S.

CLEAT DETAIL N.T.S.

CLEAT DETAIL N.T.S.

CLEAT DETAIL N.T.S.

CLEAT DETAIL N.T.S.

CLEAT DETAIL N.T.S.

CLEAT DETAIL N.T.S.

CLEAT DETAIL N.T.S.

CLEAT DETAIL N.T.S.

CLEAT DETAIL N.T.S.

CLEAT DETAIL N.T.S.

CLEAT DETAIL N.T.S.

CLEAT DETAIL N.T.S.

CLEAT DETAIL N.T.S.

CLEAT DETAIL N.T.S.

CLEAT DETAIL N.T.S.